



HEIDENHAIN



Length Gauges

April 2015

Length gauges from HEIDENHAIN offer high accuracy over long measuring ranges. These sturdily made gauges are available in application-oriented versions.

They have a wide range of applications in production metrology, in multipoint inspection stations, measuring equipment monitoring, and as position measuring devices.



This catalog supersedes all previous editions, which thereby become invalid. The basis for ordering from HEIDENHAIN is always the catalog edition valid when the contract is made.

Standards (ISO, EN, etc.) apply only where explicitly stated in the catalog.

The Interfaces of HEIDENHAIN Encoders brochure, ID 1078628-xx, includes comprehensive descriptions of all available interfaces as well as general electrical information.

Contents

Length gauges – applications and products			
	Range of applications, application examples		4
	Length gauges from HEIDENHAIN		6
	Length gauge overview		8
Technical features and mounting information			
	Measuring principles		10
	Measuring accuracy		12
	Mounting		16
	Setup		17
	Gauging force and plunger actuation		19
Specifications	<i>Accuracy</i>	<i>Measuring range</i>	
	HEIDENHAIN-ACANTO absolute length gauges	± 2 µm 12 mm 30 mm	22
	HEIDENHAIN-CERTO incremental length gauges	± 0.1 µm; ± 0.03 µm* ± 0.1 µm; ± 0.05 µm* 25 mm 60 mm	24
	HEIDENHAIN-METRO incremental length gauges	± 0.2 µm 12 mm 25 mm	26
	HEIDENHAIN-METRO incremental length gauges	± 0.5 µm ± 1 µm 60 mm 100 mm	28
	HEIDENHAIN-SPECTO incremental length gauges	± 1 µm 12 mm 30 mm	30
Accessories			
	Measuring contacts, switch boxes, coupling		32
	Gauge stands, ceramic suction plate, diaphragm compressor	For HEIDENHAIN-CERTO	34
	Cable-type lifter, gauge stands	For HEIDENHAIN-ACANTO, HEIDENHAIN-METRO and HEIDENHAIN-SPECTO	36
Electrical connection			
	Interface electronics		38
	Evaluation electronics units		40
	Interfaces		42
	Cables and connecting elements		46
Service			
	Calibration according to DAkkS		50

* After linear length-error compensation in the evaluation electronics

Areas of application

In quality assurance

Metrology and production control

Length gauges from HEIDENHAIN play a role in incoming goods inspection, fast dimension checking during production, statistical process control in production or quality assurance, or in any application where fast, reliable and accurate length measurement is required. Their large measuring lengths are a particular advantage: whether the part measures 5 mm or 95 mm, it is measured immediately with one and the same length gauge.

Whatever the application, HEIDENHAIN has the appropriate length gauge for the required accuracy. The **HEIDENHAIN-CERTO** length gauges offer a very high accuracy of $\pm 0.1 \mu\text{m}/\pm 0.05 \mu\text{m}^*/\pm 0.03 \mu\text{m}^*$ for extremely precise measurement. Length gauges from the **HEIDENHAIN-METRO** program have accuracy grades as fine as $\pm 0.2 \mu\text{m}$, while the **HEIDENHAIN-SPECTO** length gauges, with $\pm 1 \mu\text{m}$ accuracy, offer particularly compact dimensions.

* After linear length-error compensation in the evaluation electronics



Thickness gauging of silicon wafers

Gauge block calibration and measuring device inspection

The regular inspection of measuring equipment called for by standards, and the inspection of gauge blocks in particular, necessitate a large number of reference standard blocks if the comparative measurement is performed using inductive gauges. The problem is the small measuring range of inductive gauges: they can measure length differences of only up to $10 \mu\text{m}$. Length gauges, which offer large measuring ranges together with high accuracy, greatly simplify the calibration of measuring devices required to ensure traceability.

The length gauges of the **HEIDENHAIN-CERTO** program with measuring ranges of 25 mm with $\pm 0.1 \mu\text{m}/\pm 0.03 \mu\text{m}^*$ accuracy and 60 mm with $\pm 0.1 \mu\text{m}/\pm 0.05 \mu\text{m}^*$ accuracy are especially well suited for this task. It permits a significant reduction in the required number of reference standard blocks, and recalibrating becomes much simpler.



Inspection of styli

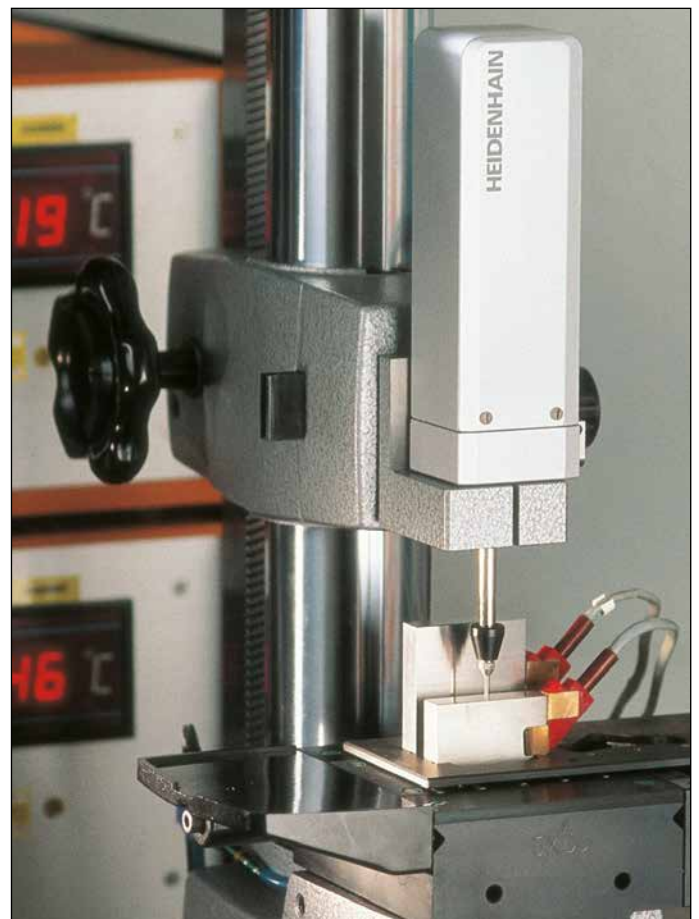

Calibration of gauge blocks

In production

Multipoint inspection apparatuses

Multipoint inspection apparatuses require durable length gauges with small dimensions. They should also have relatively large measuring ranges of several millimeters with consistent linear accuracy in order to simplify the construction of inspection devices—for example by enabling the construction of one device for several masters. A large measuring length also provides benefits in master production, because simpler masters can be used.

Thanks to their small dimensions, the **HEIDENHAIN-ACANTO** absolute length gauges, like the **HEIDENHAIN-SPECTO** incremental length gauges, are specially designed for multi-point measuring stations. They feature accuracy grades up to $\pm 1 \mu\text{m}$ over measuring ranges up to 30 mm. Higher accuracy requirements up to $\pm 0.2 \mu\text{m}$ can be met with similarly compact **HEIDENHAIN-METRO** length gauges.

Unlike inductive gauges, HEIDENHAIN-SPECTO length gauges provide stable measurement over long periods—eliminating recalibration.



Position measurement

Length gauges from HEIDENHAIN are also ideal for position measurement on precision linear slides and X-Y tables. Working with measuring microscopes, for example, becomes much easier thanks to the digital readout and the flexible datum setting.

Here, length gauges from the **HEIDENHAIN-METRO** and **HEIDENHAIN-SPECTO** program come into use with large measuring ranges of 30 mm, 60 mm or 100 mm at consistently high accuracy grades of $\pm 0.5 \mu\text{m}$ or $\pm 1 \mu\text{m}$.

In this application as linear measuring device, the length gauge's fast installation in accordance with the Abbe measuring principle by its clamping shank or planar mounting surface is of special benefit.

Testing station for flatness inspection

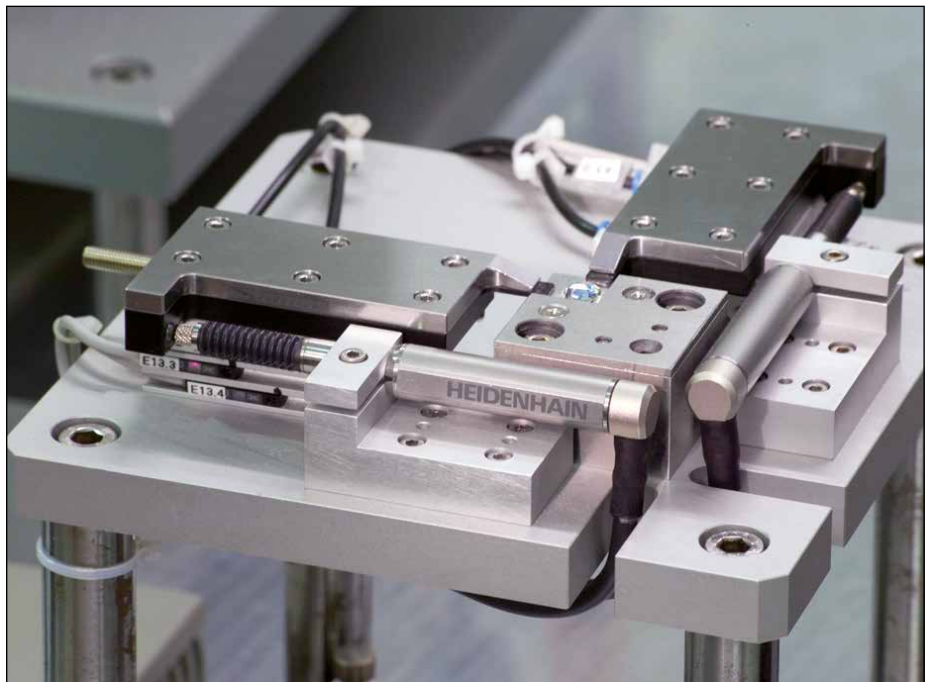

Position measurement on an X-Y table for lens mounting

Tolerance gauging of semifinished products

Length gauges from HEIDENHAIN

A number of arguments speak for HEIDENHAIN length gauges. These include not only their technical features, but also their high quality standard and the worldwide presence of HEIDENHAIN.

Large measuring ranges

HEIDENHAIN length gauges are available with measuring lengths of 12 mm, 25 mm, 30 mm, 60 mm or 100 mm. so that you can measure very different parts in one measuring setup and avoid frequently changing setups with expensive gauge blocks or masters.

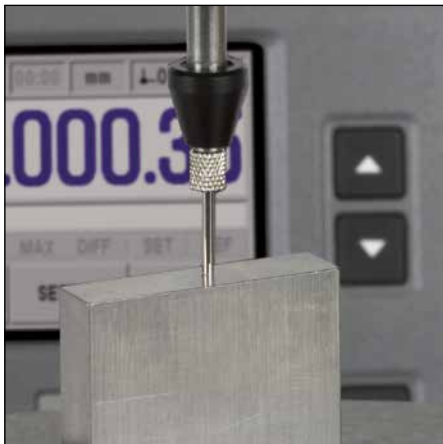

High accuracy

The high accuracy specified for HEIDENHAIN length gauges applies over the entire measuring length. Whether the part measures 10 mm or 100 mm, its actual dimension is always measured with the same high quality. The high repeatability of HEIDENHAIN length gauges comes into play during comparative measurements, for example in series production.

In particular HEIDENHAIN-CERTO length gauges provide high linear accuracy and offer resolution in the nanometer range.



Robust design

HEIDENHAIN length gauges are built for an industrial environment. They feature consistently high accuracy over a long period of time as well as high thermal stability. They can therefore be used in production equipment and machines.

Wide range of applications

HEIDENHAIN length gauges are suited for many applications. Automatic inspection equipment, manual measuring stations or positioning equipment—wherever lengths, spacing, thickness, height or linear motion are to be measured, HEIDENHAIN length gauges function quickly, reliably and accurately.



Absolute position measurement

HEIDENHAIN-ACANTO length gauges operate with absolute measurement over a range of 12 mm or 30 mm and with high repeatability. Its particular advantage is that the measured value is available immediately after switch-on.

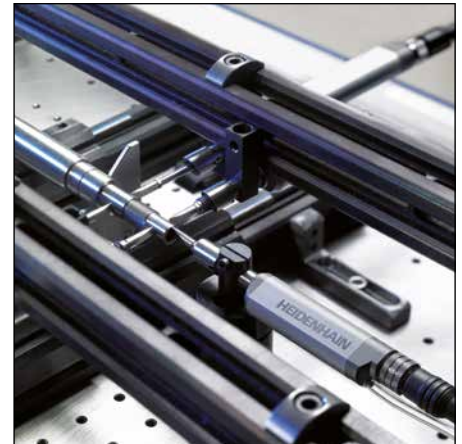

Know-how

The high quality of HEIDENHAIN length gauges is no coincidence. HEIDENHAIN has been manufacturing high-accuracy scales for over 70 years, and for many years it has developed measuring and testing devices for length and angle laboratories. This know-how makes HEIDENHAIN an extraordinarily qualified partner for metrology questions.

Worldwide presence

HEIDENHAIN is represented in all important industrial countries—in most of them with wholly owned subsidiaries. Sales engineers and service technicians support the user on-site with technical information and servicing in the local language.

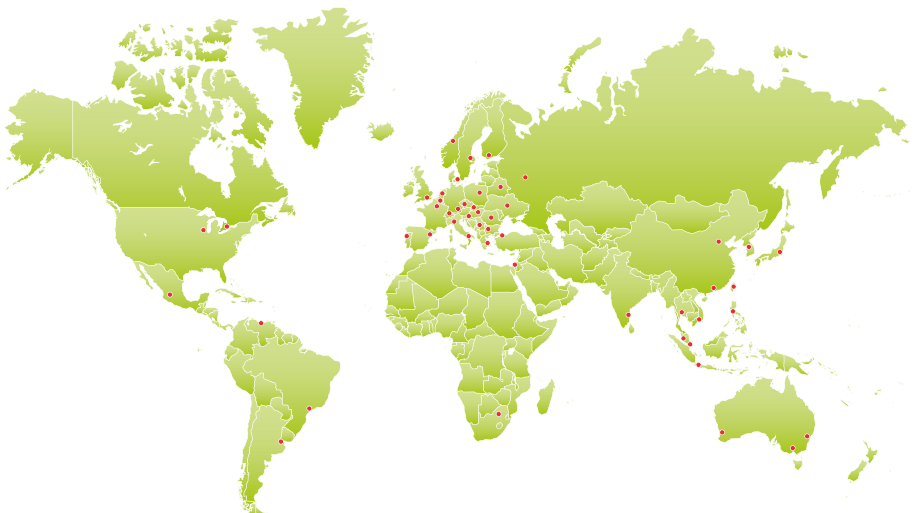

Length gauge overview



Accuracy	Measuring range <i>Plunger actuation</i>
Absolute position measurement	
$\pm 2 \mu\text{m}$	HEIDENHAIN-ACANTO <i>By measured object</i> <i>Pneumatic</i>
Incremental linear measurement	
$\pm 0.1 \mu\text{m}$ $\pm 0.05 \mu\text{m}^{*})$ $\pm 0.03 \mu\text{m}^{*})$	HEIDENHAIN-CERTO <i>By motor</i> <i>By external coupling</i>
$\pm 0.2 \mu\text{m}$	HEIDENHAIN-METRO <i>By cable lifter or measured object</i> <i>Pneumatic</i>
$\pm 0.5 \mu\text{m}$ $\pm 1 \mu\text{m}$	HEIDENHAIN-METRO <i>By motor</i> <i>By external coupling</i>
$\pm 1 \mu\text{m}$	HEIDENHAIN-SPECTO <i>By measured object</i> <i>Pneumatic</i>

^{*)} After linear length-error compensation in the ev

12 mm	25 mm/ 30 mm	60 mm	100 mm	Page
				22
AT 1218 EnDat AT 1217 EnDat	AT 3018 EnDat AT 3017 EnDat			
				24
	CT 2501 \sim 11 μ App CT 2502 \sim 11 μ App	CT 6001 \sim 11 μ App CT 6002 \sim 11 μ App		
				26
MT 1271 \square TTL MT 1281 \sim 1 V _{PP} MT 1287 \sim 1 V _{PP}	MT 2571 \square TTL MT 2581 \sim 1 V _{PP} MT 2587 \sim 1 V _{PP}			
		MT 60M \sim 11 μ App MT 60K \sim 11 μ App	MT 101M \sim 11 μ App MT 101K \sim 11 μ App	28
				30
ST 1278 \square TTL ST 1288 \sim 1 V _{PP} ST 1277 \square TTL ST 1287 \sim 1 V _{PP}	ST 3078 \square TTL ST 3088 \sim 1 V _{PP} ST 3077 \square TTL ST 3087 \sim 1 V _{PP}			

valuation electronics



Measuring principles

Measuring standard

HEIDENHAIN length gauges are characterized by long measuring ranges and consistently high accuracy. The basis for both is the photoelectrical scanning principle.

HEIDENHAIN length gauges use material measuring standards consisting of absolute or incremental graduations on substrates of glass or glass ceramic. These measuring standards permit large measuring ranges, are insensitive to vibration and shock, and have a defined thermal behavior. Changes in atmospheric pressure or relative humidity have no influence on the accuracy of the measuring standard—which is the prerequisite for the **high long-term stability** of HEIDENHAIN length gauges.

HEIDENHAIN manufactures the precision graduations in specially developed, photolithographic processes.

- AURODUR: matte-etched lines on gold-plated steel tape with typical graduation period of 40 μm
- METALLUR: contamination-tolerant graduation of metal lines on gold, with typical graduation period of 20 μm
- DIADUR: extremely robust chromium lines on glass (typical graduation period of 20 μm) or three-dimensional chromium structures (typical graduation period of 8 μm) on glass
- SUPRADUR phase grating: optically three dimensional, planar structure; particularly tolerant to contamination; typical graduation period of 8 μm and finer
- OPTODUR phase grating: optically three dimensional, planar structure with particularly high reflectance, typical graduation period of 2 μm and less

Along with these very fine grating periods, these processes permit a high definition and homogeneity of the line edges. Together with the photoelectric scanning method, this high edge definition is a precondition for the high quality of the output signals.

The master graduations are manufactured by HEIDENHAIN on custom-built high-precision dividing engines.

Measurement procedure

With the **incremental measuring method**, the graduation consists of a periodic grating structure. The position information is obtained **by counting** the individual increments (measuring steps) from some point of origin. Since an absolute reference is required to ascertain positions, the measuring standard is provided with an additional track that bears a **reference mark**. The absolute position on the scale, established by the reference mark, is gated with exactly one signal period.

The reference mark must therefore be scanned to establish an absolute reference or to find the last selected datum.

With the **absolute measuring method**, the position value is available from the encoder immediately upon switch-on and can be called at any time by the subsequent electronics. There is no need to move the axes to find the reference position. The absolute position information is read **from the graduated disk**, which is formed from a serial absolute code structure. A separate incremental track is interpolated for the position value and at the same time—depending on the interface version—is used to generate an optional incremental signal.

DIADUR phase grating with approx. 0.25 μm grating height

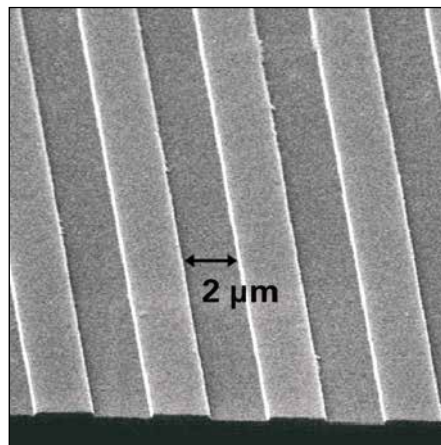

Photoelectric scanning

Most HEIDENHAIN encoders operate using the principle of photoelectric scanning. Photoelectric scanning of a measuring standard is contact-free, and as such, free of wear. This method detects even very fine lines, no more than a few microns wide, and generates output signals with very small signal periods.

The finer the grating period of a measuring standard is, the greater the effect of diffraction on photoelectric scanning. HEIDENHAIN uses two scanning principles with linear encoders:

- The **imaging scanning principle** for grating periods of 20 μm and 40 μm
- The **interferential scanning principle** for very fine graduations with grating periods of, for example, 8 μm

DIADUR graduation

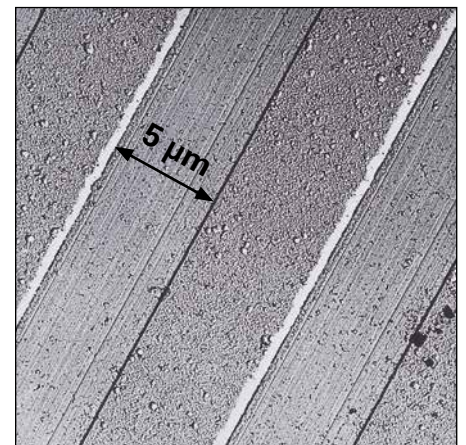

Imaging principle

To put it simply, the imaging scanning principle functions by means of projected-light signal generation: two scale gratings with equal or similar grating periods are moved relative to each other—the scale and the scanning reticle. The carrier material of the scanning reticle is transparent, whereas the graduation on the measuring standard may be applied to a transparent or reflective surface.

When parallel light passes through a grating, light and dark surfaces are projected at a certain distance. An index grating is located here. When the two gratings move relative to each other, the incident light is modulated. If the gaps in the gratings are aligned, light passes through. If the lines of one grating coincide with the gaps of the other, no light passes through. An array of photovoltaic cells converts these variations in light intensity into electrical signals. The specially structured grating of the scanning reticle filters the light to generate nearly sinusoidal output signals.

The smaller the period of the grating structure is, the closer and more tightly tolerated the gap must be between the scanning reticle and scale.

The HEIDENHAIN-ACANTO, HEIDENHAIN-SPECTO and the HEIDENHAIN-METRO length gauges of the MT 60 and MT 100 series operating according to the imaging principle.

Imaging principle

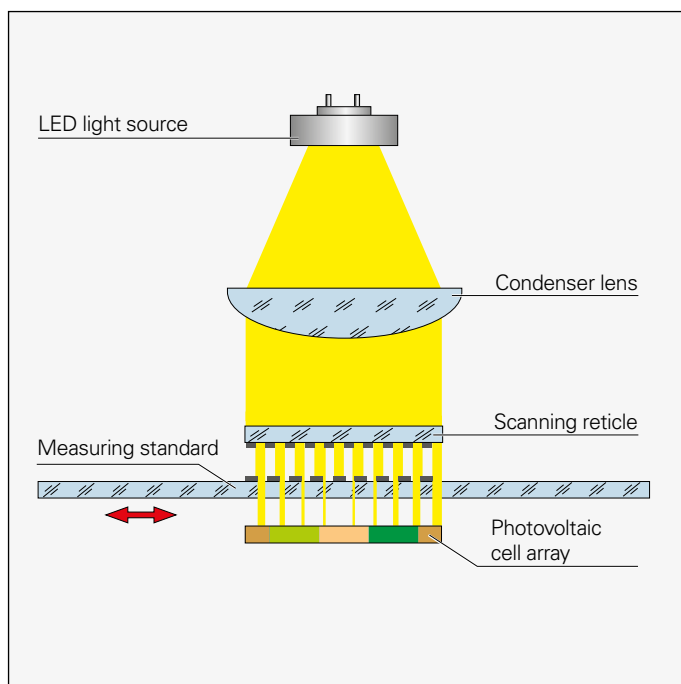

Interferential scanning principle

The interferential scanning principle exploits the diffraction and interference of light on a fine graduation to produce signals used to measure displacement.

A step grating is used as the measuring standard: reflective lines 0.2 μm high are applied to a flat, reflective surface. In front of that is the scanning reticle—a transparent phase grating with the same grating period as the scale.

When a light wave passes through the scanning reticle, it is diffracted into three partial waves of the orders -1, 0, and +1, with approximately equal luminous intensity. The waves are diffracted by the scale such that most of the luminous intensity is found in the reflected diffraction orders +1 and -1. These partial waves meet again at the phase grating of the scanning reticle where they are diffracted again and interfere. This produces essentially three waves that leave the scanning reticle at different angles. Photovoltaic cells convert this alternating light intensity into electrical signals.

A relative motion of the scanning reticle to the scale causes the diffracted wave fronts to undergo a phase shift: when the grating moves by one period, the wave front of the first order is displaced by one wavelength in the positive direction, and the wavelength of diffraction order -1 is displaced by one wavelength in the negative direction. Since the two waves interfere with each other when exiting the grating, the waves are shifted relative to each other by two wavelengths. This results in two signal periods from the relative motion of just one grating period.

Interferential encoders function with grating periods of, for example, 8 μm, 4 μm and finer. Their scanning signals are largely free of harmonics and can be highly interpolated. These encoders are therefore especially suited for high resolution and high accuracy.

The HEIDENHAIN-CERTO and the HEIDENHAIN-METRO length gauges of the MT 1200 and MT 2500 series operating according to the interferential principle.

Interferential scanning principle (optics schematics)

- C Grating period
- ψ Phase shift of the light wave when passing through the scanning reticle
- Ω Phase shift of the light wave due to motion X of the scale

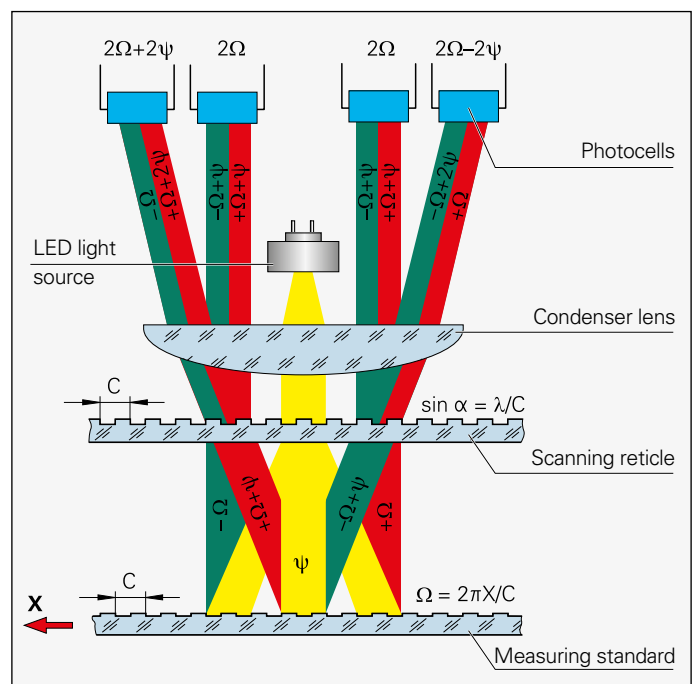

Measuring accuracy

The accuracy of linear measurement is mainly determined by

- the quality of the graduation,
- the quality of the scanning process,
- the quality of the signal processing electronics,
- the eccentricity of the graduation to the bearing,
- the error from the scale guideway relative to the scanning unit, and
- the orthogonality of the length gauge to the bearing surface.

These factors of influence are comprised of encoder-specific error and application-dependent issues. All individual factors of influence must be considered in order to assess the attainable **overall accuracy**.

Error specific to the measuring device

The error that is specific to the measuring device is shown in the Specifications as the **system accuracy**.

*The extreme values of the **total error F** with reference to their mean value lie over the entire measuring length within the system accuracy $\pm a$. They are measured during the final inspection and documented in the calibration chart.*

The system accuracy includes

- the homogeneity and period definition of the graduation,
- the alignment of the graduation,
- the error of the bearing, and
- the position error within one signal period.

Position error within one signal period

Position errors within one signal period already become apparent in very small motions and in repeated measurements. They are therefore considered separately.

The position error within one signal period $\pm u$ results from the quality of the scanning and—for encoders with integrated pulse-shaping or counter electronics—the quality of the signal-processing electronics. For encoders with sinusoidal output signals, however, the errors of the signal processing electronics are determined by the subsequent electronics.

The following individual factors influence the result:

- The size of the signal period
- The homogeneity and period definition of the graduation
- The quality of scanning filter structures
- The characteristics of the sensors
- The stability and dynamics of further processing of the analog signals

These deviations are to be considered when specifying position error within one signal period.

Position error within one signal period $\pm u$ is specified in percent of the signal period. For length gauges, the value is typically better than $\pm 1\%$ of the signal period. You will find the specified values in the Specifications.

Short-range accuracy

The short-range accuracy describes an error that occurs within a distance of $\pm 100 \mu\text{m}$ from a measuring point. It includes electronic and mechanical influences of the gauge on the result of measurement. The values for short-range accuracy typically lie below the specified values.

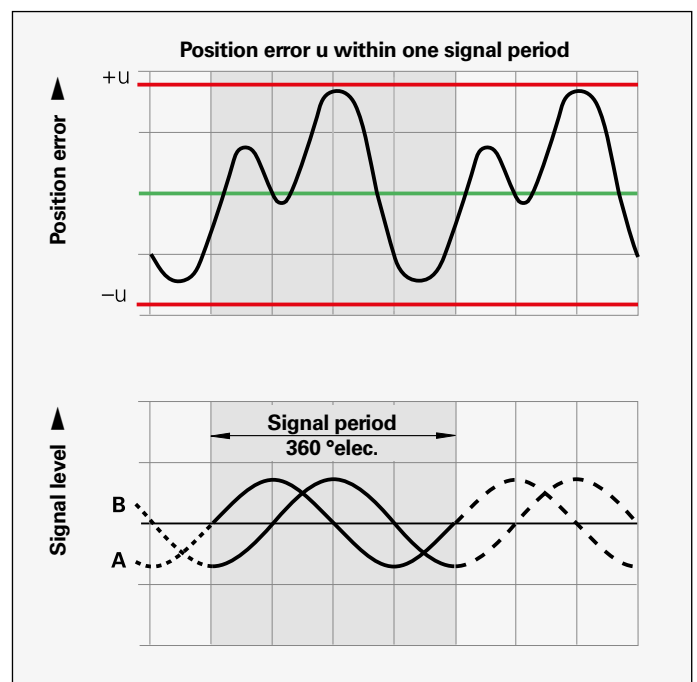
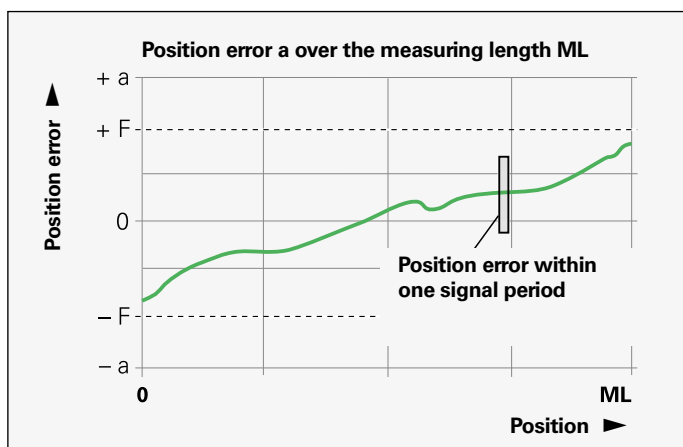

Application-dependent error

Other factors besides the system accuracy also influence the attainable total accuracy of measurement. These include in particular the ambient temperature and temperature fluctuations during measurement as well as a stable, orthogonal measuring setup.

All components included in the **measuring loop**, such as the holder for the measured object, the gauge stand with holder, and the length gauge itself, influence the result of measurement. Expansion or deformation of the measuring setup through mechanical or thermal influences adds directly to the error.

Mechanical design

A stable measuring assembly must be ensured. Long lateral elements within the measuring loop are to be avoided. HEIDENHAIN offers a stable gauge stand as an accessory. The force resulting from the measurement must not cause any measurable deformation of the measuring loop.

Length gauges from HEIDENHAIN operate with small gauging force and have very little influence on the measuring setup.

The measuring loop: All components involved in the measuring assembly, including the length gauge

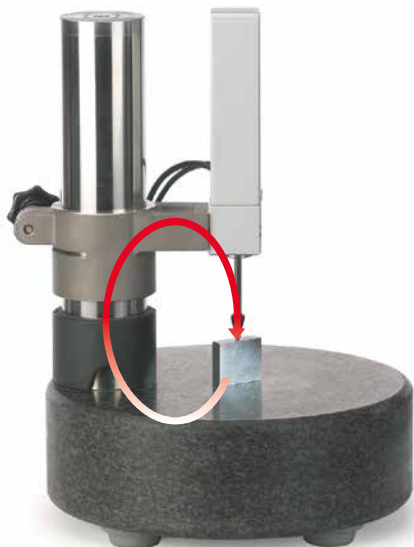

Orthogonal mounting

The length gauge is to be mounted so that its plunger is exactly orthogonal to the measured object or the surface on which it rests. Deviations result in measuring error.

The accessory HEIDENHAIN gauge stands with holders for an **8 mm clamping shank** ensure orthogonal mounting. Length gauges that provide **planar mounting surfaces** are to be adjusted in the direction parallel to the mounting surface (Y) to be perpendicular to the measuring plate. A quick and reliable adjustment is possible with the aid of a gauge block or a parallel block. The perpendicularity to the measuring table (X) is already ensured by the gauge stand.



Orthogonal mounting

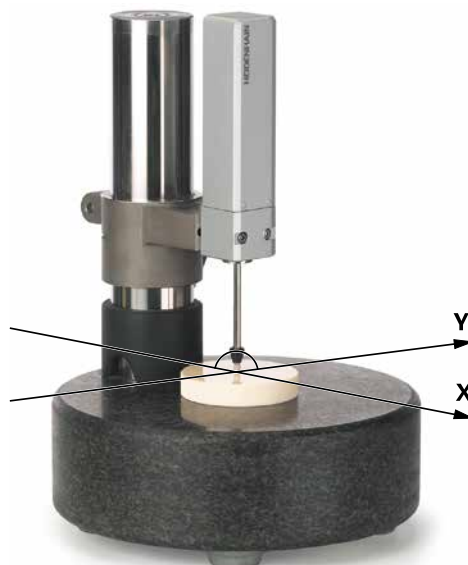

Thermal characteristics

Temperature variations during measurement cause changes in length or deformation of the measuring setup. After a change in temperature of 5 K, a steel bar of 200 mm length expands by 10 μm .

Length changes resulting from a uniform deviation from the reference temperature can largely be compensated by resetting the datum on the measuring plate or a master; only the expansion of the scale and measured object go into the result of measurement.

Temperature changes during measurement cannot be ascertained mathematically. For critical components, HEIDENHAIN therefore uses special materials with low coefficients of expansion, such as are found in the HEIDENHAIN-CERTO gauge stand. This makes it possible to guarantee the high accuracy of HEIDENHAIN-CERTO even at ambient temperatures of 19 °C to 21 °C and variations of ± 0.1 K during measurement.

In order to measure with complete accuracy, the length gauge should be switched on approximately 15 minutes before the first measurement.

Thermally induced change in length:

Expansion of the measuring loop components as a result of heat

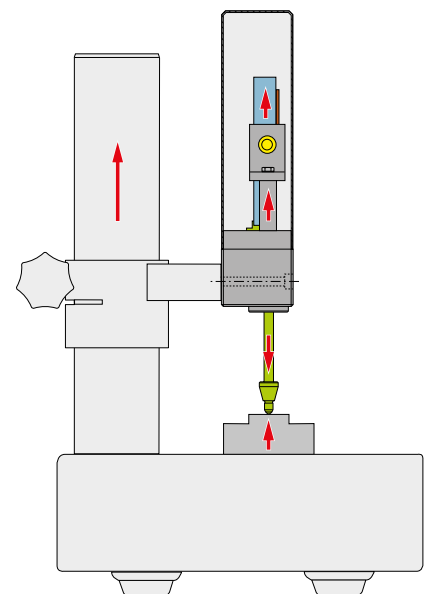

Calibration chart

All HEIDENHAIN length gauges are inspected before shipping for accuracy and proper function.

They are calibrated for accuracy during retraction and extension of the plunger. For HEIDENHAIN-CERTO gauges, the number of measuring positions is selected to ascertain very exactly not only the long-range error, but also the position error within one signal period.

The **Quality Inspection Certificate** confirms the specified system accuracy of each length gauge. The **calibration standards** ensure the traceability—as required by EN ISO 9001—to recognized national or international standards.

For the HEIDENHAIN-METRO and HEIDENHAIN-CERTO series, a **calibration chart** documents the position error over the measuring range. It also shows the measuring step and the measuring uncertainty of the calibration measurement.

For HEIDENHAIN-METRO gauges the calibration chart shows the mean value of one forward and one backward measuring stroke.

The HEIDENHAIN-CERTO calibration chart shows the envelope curve of the measured error. The HEIDENHAIN-CERTO length gauges are supplied with two calibration charts, each for different operating attitudes.

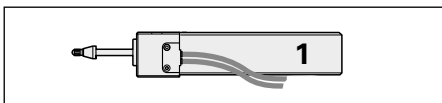

Operating attitude for calibration chart 1

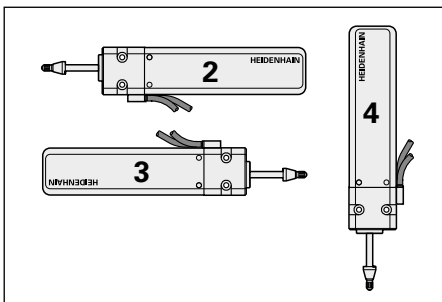

Operating attitude for calibration chart 2



DR. JOHANNES HEIDENHAIN GmbH · 83301 Traunreut, Germany · www.heidenhain.de · Telefon: +49 (8669) 31-0 · Fax: +49 (8669) 5061

20.12.2007
 Prüfer/Inspected by  H. Gawron

Example

Temperature range

The length gauges are inspected at a **reference temperature** of 20 °C. The system accuracy given in the calibration chart applies at this temperature.

The **operating temperature** indicates the ambient temperature limits between which the length gauges will function properly. The **storage temperature range** of -20 °C to 60 °C applies for the device in its packaging.

Repeatability

Whereas the system accuracy applies over the entire measuring range, for some applications the repeatability is the decisive factor. It plays an important role in repeated measurements.

Repeatability is defined in the standards DIN 32876 and DKD-R 4-3, and describes a length gauge's capability to supply very similar measured values for identical measurands and conditions.

HEIDENHAIN ascertains the repeatability of the length gauges with five measurements near the lower plunger stop. The plunger is completely extended and retracted at medium speed. Since the length gauge was already in operation for at least 10 minutes before this, it is already in a stable thermal state.

The repeatability of the length gauges is usually better than the values listed in the table. The characteristic statistical distribution is shown in the diagram, using the ST 1200 as an example.

- Repeatability depends on the
- combinations of materials used in the components,
 - installed electronics,
 - optomechanics used, and the
 - bearing of the plunger.

Series	Repeatability < $\bar{x} \pm 2\sigma$
AT 1200	0.4 μm
AT 3000	0.8 μm
CT 2500	0.02 μm
CT 6000	0.03 μm
MT 101	0.04 μm
MT 1200	0.03 μm
MT 2500	0.09 μm
MT 60	0.06 μm
ST 1200	0.25 μm
ST 3000	0.7 μm

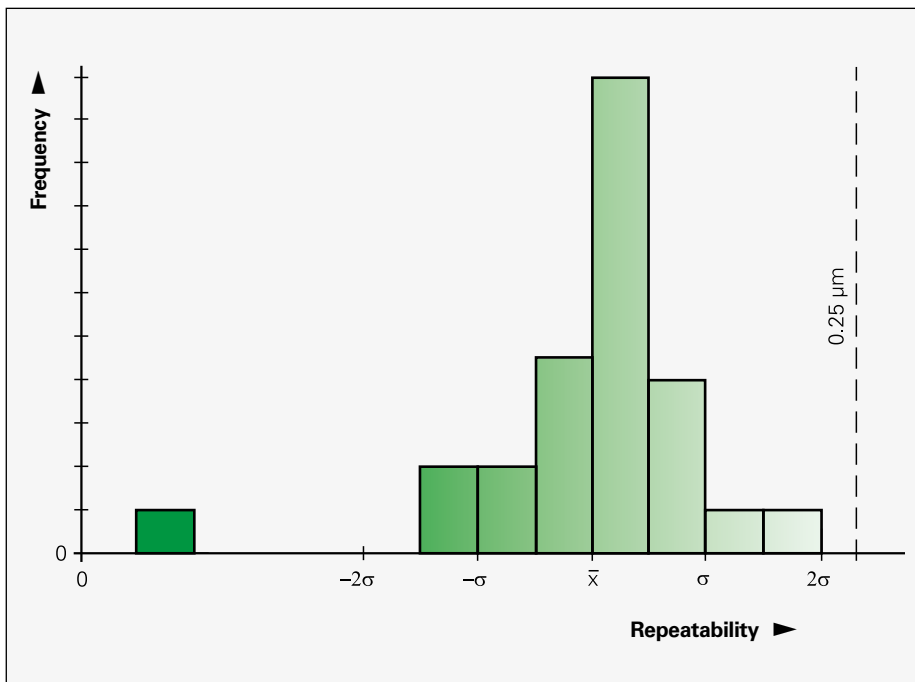

ST 1200: Statistical distribution of the repeatability

Mounting

Abbe principle

HEIDENHAIN length gauges enable you to work according to the Abbe measuring principle: The measured object and scale must be in alignment to avoid additional measuring error.

Fastening

The **CT 6000**, **MT 60** and **MT 101** length gauges are fastened by two screws onto a plane surface. This ensures a mechanically stable installation of even these large length gauges. Special holders are available for fastening the MT 60 and MT 101 to the MS 100 gauge stand for the HEIDENHAIN-METRO (see *Accessories*).

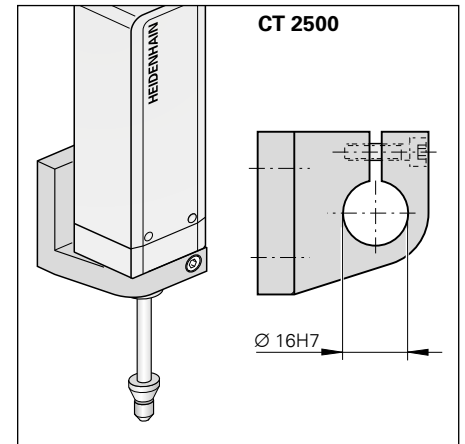
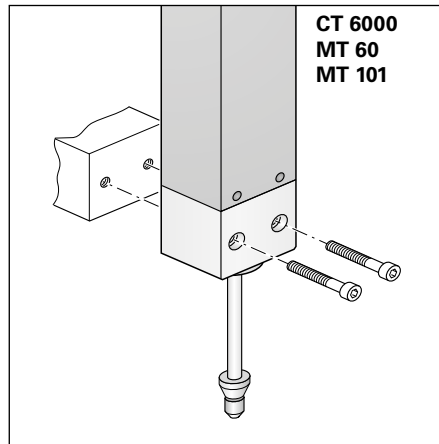

The **CT 2500** is mounted by its standard clamping shank with 16h8 diameter. A holder is available for fastening the HEIDENHAIN-CERTO to the gauge stand (see *Accessories*).

The **AT**, **ST**, **MT 1200** and **MT 2500** length gauges feature a standard clamping shank with 8h6 diameter. These HEIDENHAIN length gauges can therefore easily be used with existing measuring fixtures and stands.

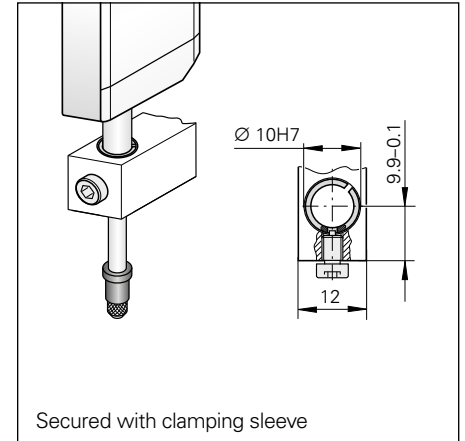
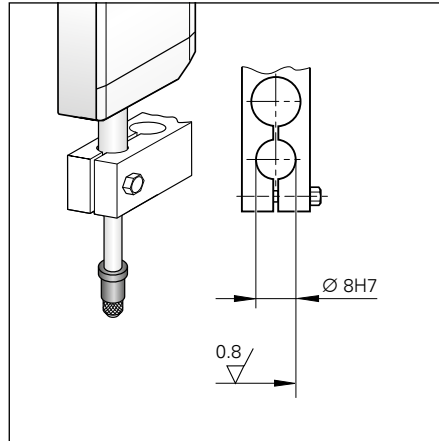

As an accessory, HEIDENHAIN offers a special clamping sleeve and screw. It facilitates fastening the length gauge securely without overstressing the clamping shank.

Clamping sleeve ID 386811-01

mm

 Tolerancing ISO 8015
 ISO 2768 - m H
 < 6 mm: ±0.2 mm

Operating attitude for HEIDENHAIN-CERTO

The HEIDENHAIN-CERTO can be operated at any attitude. However, the mounting position with horizontal length gauge and upward facing mounting surface should be avoided because in such a case no guarantee can be made for accuracy.

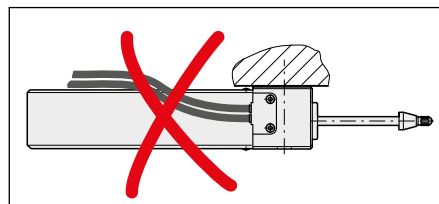

Setup

HEIDENHAIN length gauges function according to the **Abbe measuring principle**, i.e. the measuring standard and the plunger are exactly aligned. All components comprising the **measuring loop**, such as the measuring standard, plunger, holder and scanning head are designed in terms of their mechanical and thermal stability for the highest possible accuracy of the length gauge.

The **plungers** of the HEIDENHAIN length gauges are locked against rotation. Their optimally round form stays unchanged while stability and thermoconductivity remain unimpaired. They are provided with an M2.5 thread to hold measuring contacts (see *Accessories*)

The plungers of the HEIDENHAIN-ACANTO and HEIDENHAIN-SPECTO ST 1200 length gauges are protected by a rubber bellows. The **bellows** are characterized by high resistance to chemical and thermal influences and have a relatively low stiffness. Its influence on the gauge's mechanical behavior and the measuring force is therefore low.

Thermal characteristics

HEIDENHAIN length gauges have a defined thermal behavior. Since temperature variations during measurement can result in changes in the measuring loop, HEIDENHAIN uses special materials with low coefficients of expansion α_{therm} for the components of the measuring loop, for example in the HEIDENHAIN-CERTO length gauges. The scale is manufactured of Zerodur ($\alpha_{\text{therm}} \approx 0 \text{ K}^{-1}$), and the plunger and holder are of Invar ($\alpha_{\text{therm}} \approx 1 \times 10^{-6} \text{ K}^{-1}$). This makes it possible to guarantee its high measuring accuracy over a relatively large temperature range.

Acceleration

Length gauges from HEIDENHAIN feature a **sturdy design**. Even high vibration and shock loads have no negative influence on the accuracy.

However, shock and vibration of any kind is to be avoided during measurement so as not to impair the high accuracy of measurement. The maximum values given in the specifications for shock and vibration apply to the effect of external acceleration on the length gauge. They describe only the mechanical stability of the length gauge, and imply no guarantee of function or accuracy.

In the length gauge itself, unchecked extension of the spring-driven or non-coupled moving plunger can cause high acceleration onto the measured object or measuring plate surface. For the MT 1200 and MT 2500 series length gauges, use the cable-type lifter whenever possible (see *Accessories*). The cable lifter features adjustable pneumatic damping to limit the extension velocity to an uncritical value.

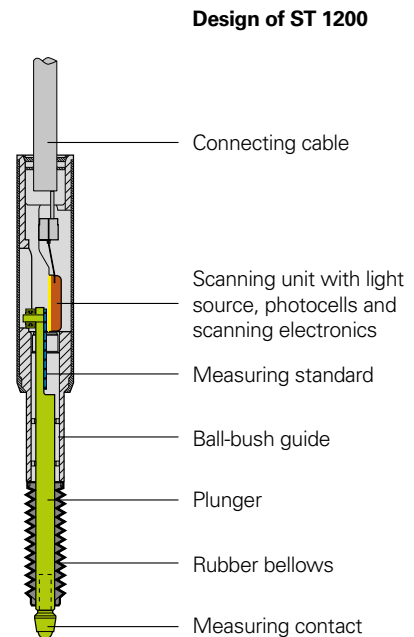
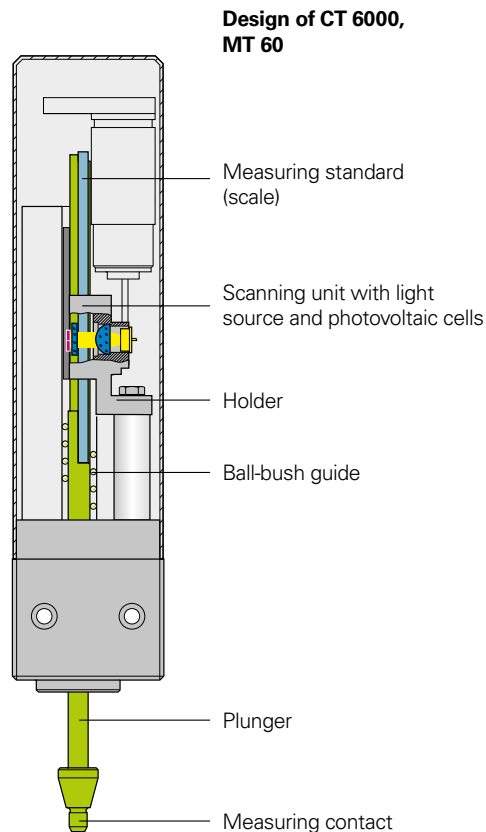

Plunger guideway

HEIDENHAIN length gauges are available with various plunger guides.

The plungers of the HEIDENHAIN-ACANTO length gauges work with **sliding guides**.

The sliding guides have the following properties:

- Sturdiness thanks to few moving parts
- High tolerance to shock and vibration
- High plunger speeds and long service life thanks to high-quality ceramic bearings
- Less sensitivity to improper clamping

The HEIDENHAIN-METRO, HEIDENHAIN-CERTO, and HEIDENHAIN-SPECTO length gauges are equipped with a **ball-bush guide**. The following are some of the basic properties of ball guides in HEIDENHAIN length gauges:

- Low friction, which makes versions of length gauges with reduced gauging force possible
- Safe plunger extension and retraction even with high radial force
- High precision of the measuring loop thanks to a guide that is free of play (the bearing and plunger are specially fitted during manufacture)

Expendable parts

HEIDENHAIN length gauges contain components that are subject to wear, depending on the application and handling. These include in particular the following parts:

- Guideway (tested for at least 60 million strokes*)
- Cable link for CT, MT 60 and MT 101 (tested for at least 1 million strokes*)
- Scraper rings
- Rubber bellows for AT and ST 1200

* With CT, MT 60 M and MT 101 M only with actuation by switch box

Note

DIADUR is a registered trademark of DR. JOHANNES HEIDENHAIN GmbH, Traunreut, Germany.

Zerodur® is a registered trademark of Schott Glaswerke in Mainz, Germany.



Sliding guide



Ball-bush guide

Gauging force – plunger actuation

Gauging force

Gauging force is the force that the plunger exerts on the measured object. An excessively large gauging force can cause deformation of the measuring contact and the measured object. If the gauging force is too small, an existing dust film or other obstacle may prevent the plunger from fully contacting the measured object. The gauging force depends on the type of plunger actuation.

Plunger actuation by spring

For the AT 1218, AT 3018, MT 12x1, MT 25x1, ST 12x8 and ST 30x8, the integral spring extends the plunger to the measuring position and applies the **gauging force**. In its resting position, the plunger is extended. The gauging force depends on the following criteria:

- The operating attitude
- The plunger position, i.e. the force changes over the measuring range
- The measuring direction, i.e., whether the gauge measures with extending or retracting plunger

In the diagrams, the measuring force is shown over the measuring range for a retracting and extending plunger in a horizontal operating attitude.

The MT 1281 and ST 1288 length gauges are available with various gauging forces. Particularly for fragile materials this makes it possible to measure without deformation.

The gauging forces can be divided into the following classes:

- Reduced MR: Approx. half the gauging force of the standard variant.
- Low MW: Gauging force at the beginning of the measuring range, approx 0.01 N
- Springless MG: Constant gauging force over the entire measuring range

In order not to influence the gauging force, the variants ST 1288MR and ST 1288MG are provided without a rubber bellows. Due to their low gauging force, the variants MT 1281 MW, MT 1281 MG and ST 1288MG can only be used for measuring vertically downward. For this reason, the diagram shows only gauging forces for a vertical operating orientation.

Plunger actuation by measured object

The complete length gauge is moved relative to the measured object, normally while the plunger retracts.

Plunger actuation via cable-type lifter (MT 12x1, MT 25x1)

Through a cable mechanism, the plunger is retracted by hand and then extended onto the measured object. The measurement is made with extending plunger.

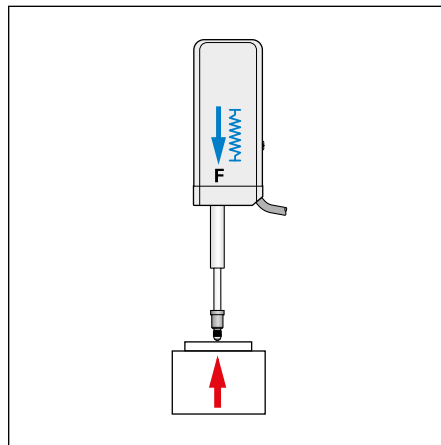
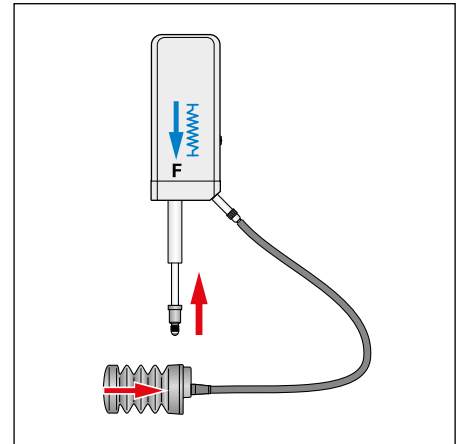

The integral pneumatic damping reduces the plunger extension speed to prevent bouncing, for example on very hard materials. This prevents measuring error through bouncing.

Special variants

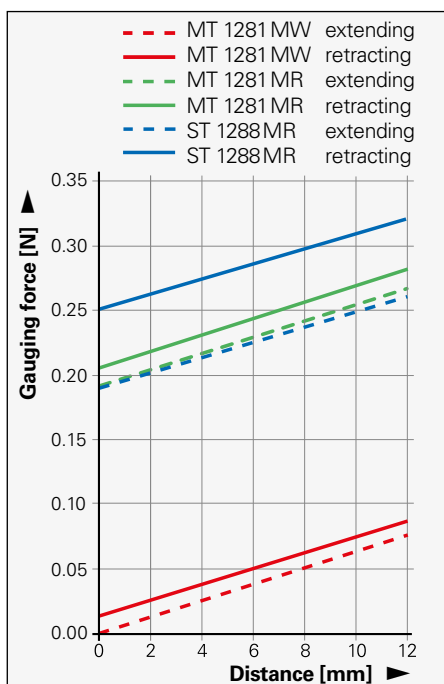

12 mm measuring range

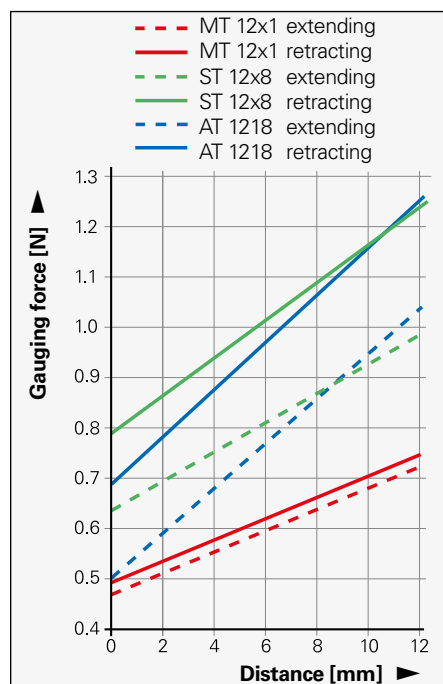

25 mm/30 mm measuring range

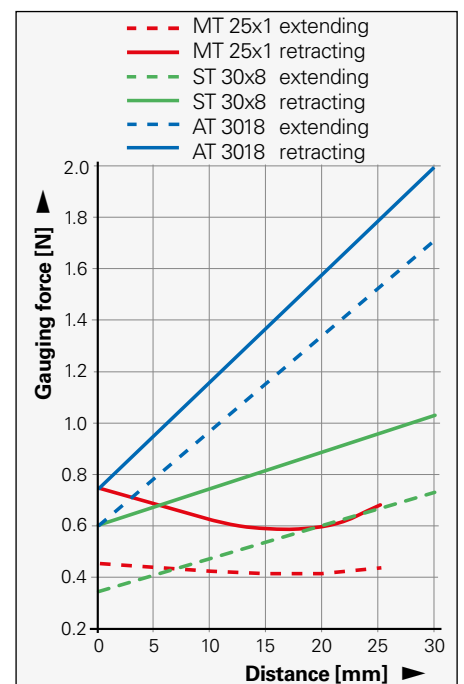

Pneumatic plunger actuation

The pneumatically actuated plungers of the AT 1217, AT 3017, MT 1287, MT 2587, ST 12x7 and ST 30x7 length gauges are extended by the application of compressed air. When the air connection is ventilated, the integral spring retracts the plunger to a protected resting position within the housing.

The **gauging force** can be adjusted to the measuring task through the level of air pressure. At constant pressure, it depends on the operating attitude and the plunger position.

The diagrams show the respective measuring force for a horizontal operating attitude depending on the working pressure applied with the plunger fully extended and fully retracted. These are approximate values that are subject to changes due to tolerances and depend on seal wear.

The working pressure defines the pressure range of the first complete plunger extension up to the maximum specified range.

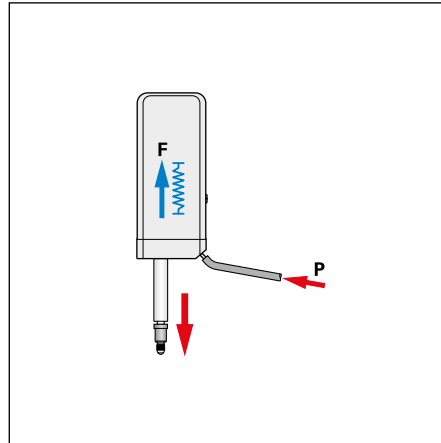

Note

The compressed air introduced directly into the length gauges must be properly conditioned and must comply with the following quality classes as per **ISO 8573-1** (1995 edition):

- Solid contaminants Class 1 (max. particle size 0.1 μm and max. particle density 0.1 mg/m^3 at $1 \cdot 10^5$ Pa)
- Total oil content: Class 1 (max. oil concentration 0.01 mg/m^3 at $1 \cdot 10^5$ Pa)
- Max. pressure dew point: Class 4, but with reference conditions of $+3$ °C at $2 \cdot 10^5$ Pa

HEIDENHAIN offers the **DA 400 compressed air unit** for purifying compressed air. The minimum flow rate is 10 l/min.

For more information, ask for our **DA 400** Product Information Sheet.

12 mm measuring range
(pneumatically actuated)

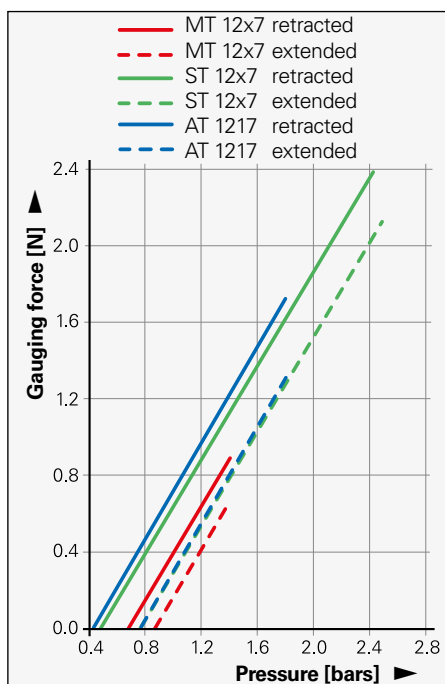

25 mm/30 mm measuring range
(pneumatically actuated)

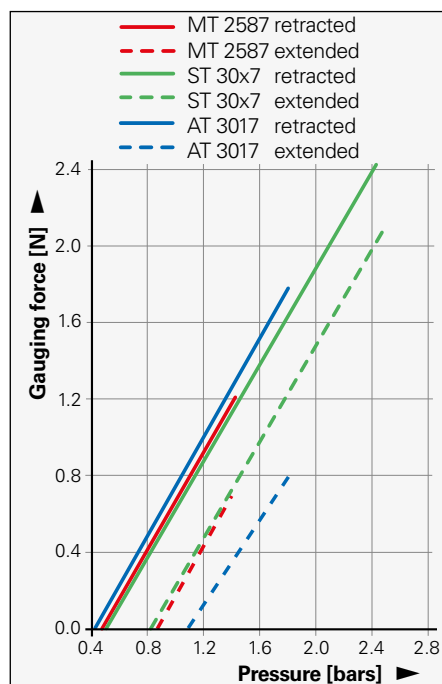

Except for special variants, the diagrams apply for the **horizontal operating attitude**. The following compensation values are to be taken into account for other operating attitudes.

Type	Operating attitude vertical	
	North	South
AT 121x AT 301x	- 0.12 N - 0.18 N	+ 0.12 N + 0.18 N
MT 12xx MT 25x1 MT 2587	- 0.13 N - 0.17 N - 0.19 N	+ 0.13 N + 0.17 N + 0.19 N
ST 12x7 ST 12x8 ST 30xx	- 0.07 N - 0.08 N - 0.11 N	+ 0.07 N + 0.08 N + 0.11 N

Motorized plunger actuation

The CT 2501, CT 6001, MT 60M and MT 101 M length gauges feature an integral motor that moves the plunger. It is operated through the switch box either by push button or over the connection for external actuation. The plungers of the CT 2501, CT 6001 and MT 60M length gauges must not be moved by hand if the switch box is connected.

The **gauging force** of the CT 2501, CT 6001, and MT 60 M motorized length gauges is adjustable in three stages through the switch box. The force remains constant over the measuring range but depends on the operating attitude. Regardless of the operating attitude—whether it measures vertically downward (with the SG 101 V switch box) or horizontally (with the SG 101 H switch box)—the MT 101 M exercises a constant gauging force.

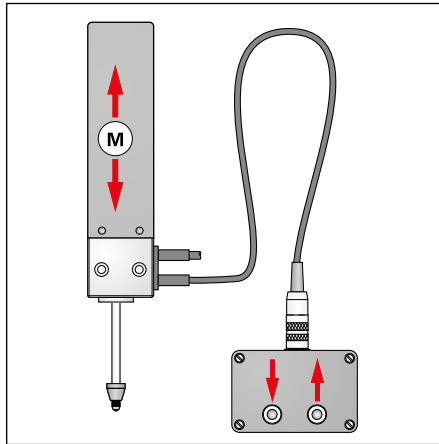

	CT 2501 CT 6001	MT 60M	MT 101 M
Gauging force	By motor	By motor	By motor
Vertically downward	1 N/1.25 N/1.75 N	1 N/1.25 N/1.75 N	0.7 N with SG 101V
Vertically upward	-/-/0.75 N	-/-/0.75 N	-
Horizontal	-/0.75 N/1.25 N	-/0.75 N/1.25 N	0.7 N with SG 101 H

External plunger actuation by coupling

For the CT 2502, CT 6002, MT 60K, MT 101 K and special versions (without spring) of the MT 1200, MT 2500, and ST 1288, the plunger is freely movable. For position measurement, the plunger is connected by a coupling with a moving machine element. The force needed to move the plunger is specified as the required **moving force**. It depends on the operating attitude.

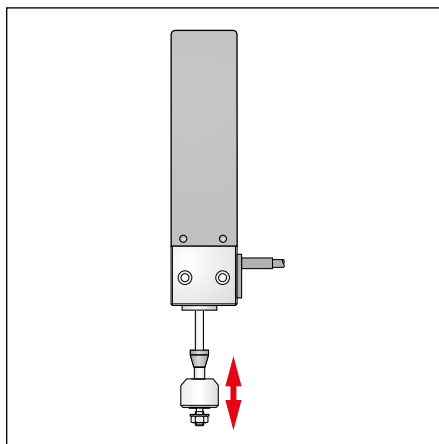

	CT 2502 CT 6002	MT 60K	MT 101K	MT 1271 \square TTL MT 1281 \sim 1 V _{PP}	MT 2571 \square TTL MT 2581 \sim 1 V _{PP}	ST 1288
Gauging force	Moving force ¹⁾	Moving force ¹⁾	Moving force ¹⁾	-	-	-
Vertically downward	0.6 N	0.35 N	1.7 N	0.13 N	0.17 N	0.2 N
Vertically upward	0.1 N	0.1 N	2 N	-	-	-
Horizontal	0.6 N	0.5 N	0.4 N	-	-	-

¹⁾ Force required to move the plunger or of its weight

HEIDENHAIN-ACANTO

Absolute length gauges with EnDat interface

- Very compact dimensions
- Splash-proof
- Plain-bush guided plunger

AT 1200

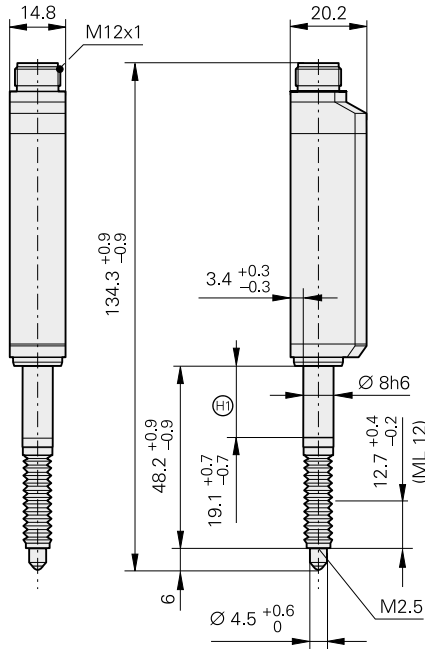

AT 3000

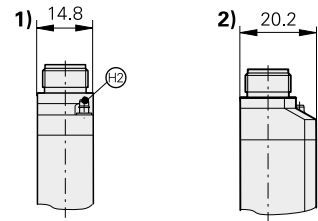
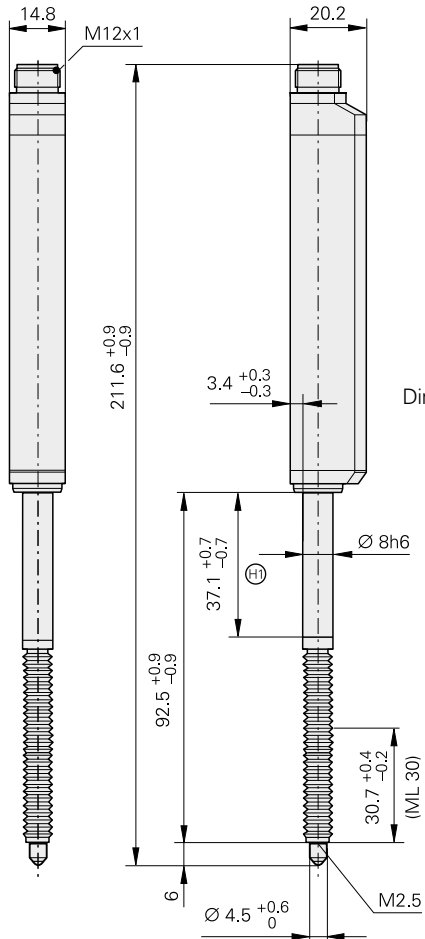

Dimension changes under max. pressure (1.8 bars)

	1)	2)
AT 1217	14.8...15.1	20.2...19.9
AT 3017	14.8...15.2	20.2...19.8

mm

Tolerancing ISO 8015
 ISO 2768 - m H
 < 6 mm: ±0.2 mm

ML = Measuring length
 ⊕ = Clamping area
 ⊕ = Air connection for 2 mm tube

Mechanical data	AT 1218	AT 3018	AT 1217	AT 3017
Plunger actuation Position of plunger at rest	By measured object Extended		Pneumatic Retracted	
Measuring standard	DIADUR grating on glass; grating period 188.4 µm			
System accuracy	± 2 µm			
Position error per signal period	≤ ± 0.7 µm			
Measuring range	12 mm	30 mm	12 mm	30 mm
Working pressure	–		0.7 bar to 1.8 bars	1.1 bars to 1.8 bars
Mech. permissible traversing speed	≤ 80 m/min	≤ 120 m/min	≤ 80 m/min	≤ 120 m/min
Radial force	≤ 0.5 N (mechanically permissible)			
Fastening	Clamping shank Ø 8h6			
Operating attitude	Any			
Vibration 55 Hz to 2 000 Hz Shock 11 ms	≤ 100 m/s ² (EN 60068-2-6) ≤ 500 m/s ² (EN 60068-2-27)			
Operating temperature	10 °C to 40 °C; reference temperature 20 °C			
Protection EN 60529	IP 67		IP 64 ¹⁾ IP 67 upon request	IP 64 ¹⁾
Weight without cable	80 g	100 g	80 g	100 g

¹⁾ IP67 with sealing air

Electrical data	EnDat			
Interface	EnDat 2.2			
Ordering designation	EnDat 22			
Resolution	23 nm	368 nm	23 nm	368 nm
Calculation time t_{cal} Clock frequency	≤ 5 µs ≤ 8 MHz			
Electrical connection	M12 flange socket (male) 8-pin			
Cable length	≤ 100 m with HEIDENHAIN cable			
Voltage supply	3.6 V to 14 V DC			
Power consumption (max.)	3.6 V: ≤ 550 mW 14 V: ≤ 650 mW			
Current consumption (typical)	5 V: 80 mA (without load)			

HEIDENHAIN-CERTO

Incremental length gauges with $\pm 0.1 \mu\text{m}/\pm 0.05^{1)} \mu\text{m}^*/\pm 0.03 \mu\text{m}^1)$ accuracy

- For very high accuracy
- For inspection of measuring equipment and gauge blocks
- Ball-bush guided plunger

CT 2500

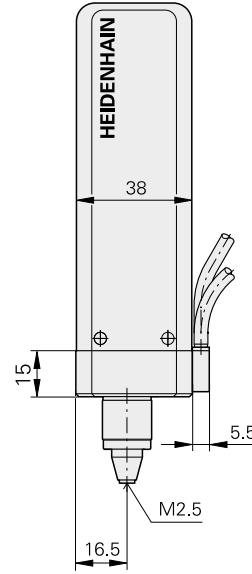
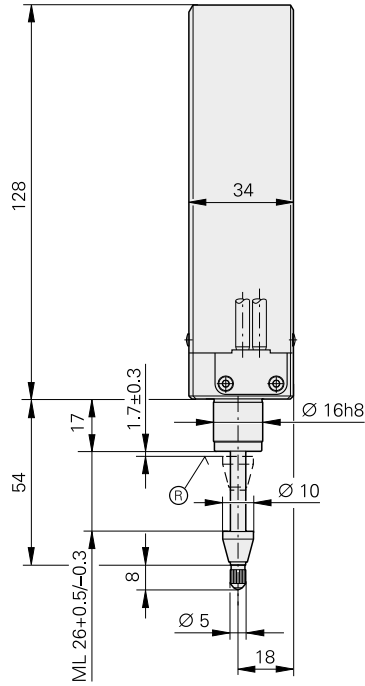

CT 6000

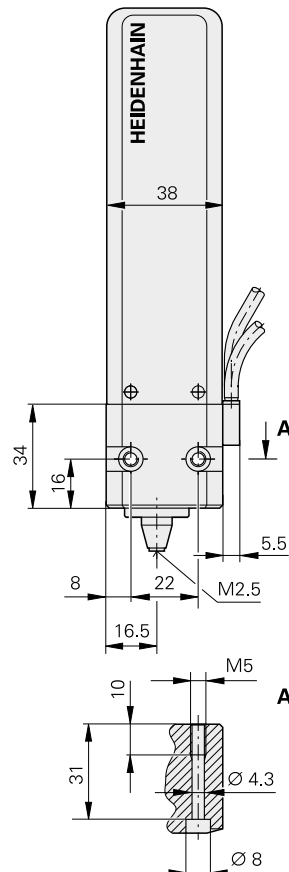
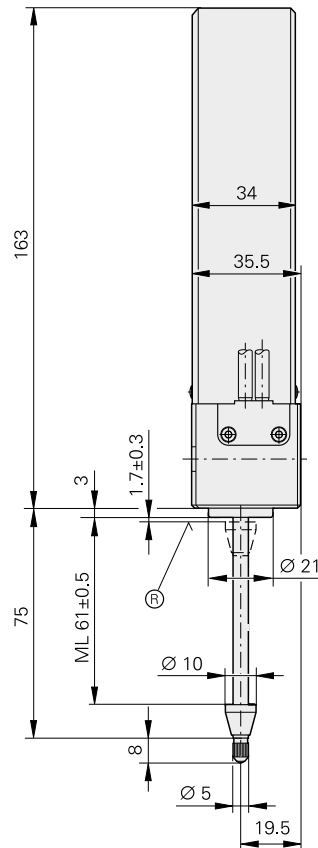

mm

 Tolerancing ISO 8015
 ISO 2768 - m H
 < 6 mm: ± 0.2 mm

⊕ = Reference mark position

Specifications	CT 2501	CT 6001	CT 2502	CT 6002
Plunger actuation	By motor		Via coupling with moving machine part	
Measuring standard	DIADUR phase grating on Zerodur glass ceramic; grating period 4 µm			
System accuracy At 19 °C to 21 °C	± 0.1 µm, ± 0.03 µm ¹⁾	± 0.1 µm, ± 0.05 µm ¹⁾	± 0.1 µm, ± 0.03 µm ¹⁾	± 0.1 µm, ± 0.05 µm ¹⁾
Position error per signal period	≤ ± 0.02 µm			
Short-range accuracy typically	0.03 µm			
Reference mark	One, ≈ 1.7 mm below upper stop			
Measuring range	25 mm	60 mm	25 mm	60 mm
Radial force	≤ 0.5 N (mechanically permissible)			
Fastening	Clamping shank Ø 16h8	Plane surface	Clamping shank Ø 16h8	Plane surface
Operating attitude	Any required (for preferred operating attitude see <i>Mounting</i>)			
Vibration 55 to 2000 Hz Shock 11 ms	≤ 100 m/s ² (EN 60068-2-6) ≤ 1000 m/s ² (EN 60068-2-27)			
Operating temperature	10 °C to 40 °C; reference temperature 20 °C			
Protection EN 60529	IP50			
Weight without cable	520 g	700 g	480 g	640 g

Electrical data	CT 2501	CT 6001	CT 2502	CT 6002
Interface	~ 11 µA _{PP}			
Signal period	2 µm			
Measuring velocity	≤ 24 m/min (depending on the subsequent electronics) ≤ 12 m/min with the ND 28x display unit			
Electrical connection*	<ul style="list-style-type: none"> • Cable 1.5 m with D-sub connector (male), 15-pin • Cable 1.5 m with M23 connector (male), 9 pin Interface electronics are integrated in connector.			
Cable length	≤ 30 m			
Voltage supply	5 V DC ± 0.25 V / < 170 mA		5 V DC ± 0.25 V / < 120 mA	

Required accessories*	For CT 2501	For CT 6001
Switch box	SG 25M	SG 60M

* Please select when ordering

¹⁾ After linear length-error compensation in the evaluation electronics

²⁾ Force required to move the plunger or of its weight

HEIDENHAIN-METRO

Incremental length gauges with $\pm 0.2 \mu\text{m}$ accuracy

- High repeatability
- Plunger actuation by cable release, by the workpiece or pneumatically
- Ball-bush guided plunger

MT 1200

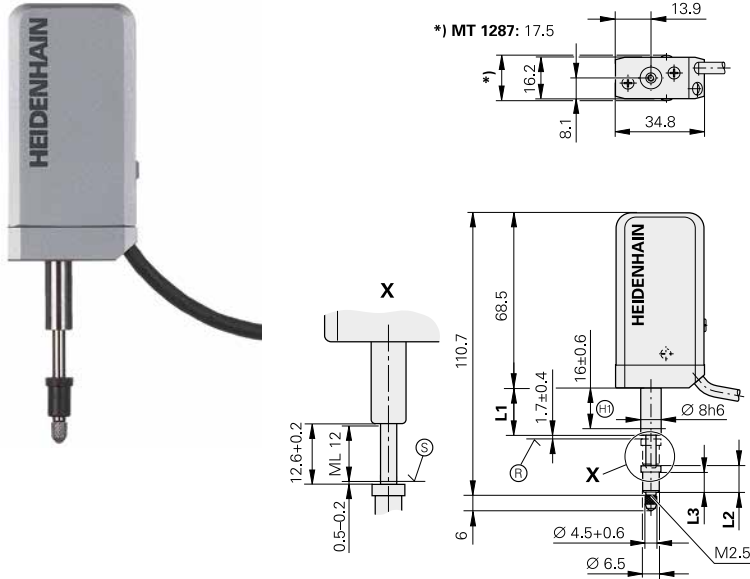

	MT 12x1	MT 1287
L1	18.5	22.0
L2	10.1	6.2
L3	8.1	4.2

MT 2500

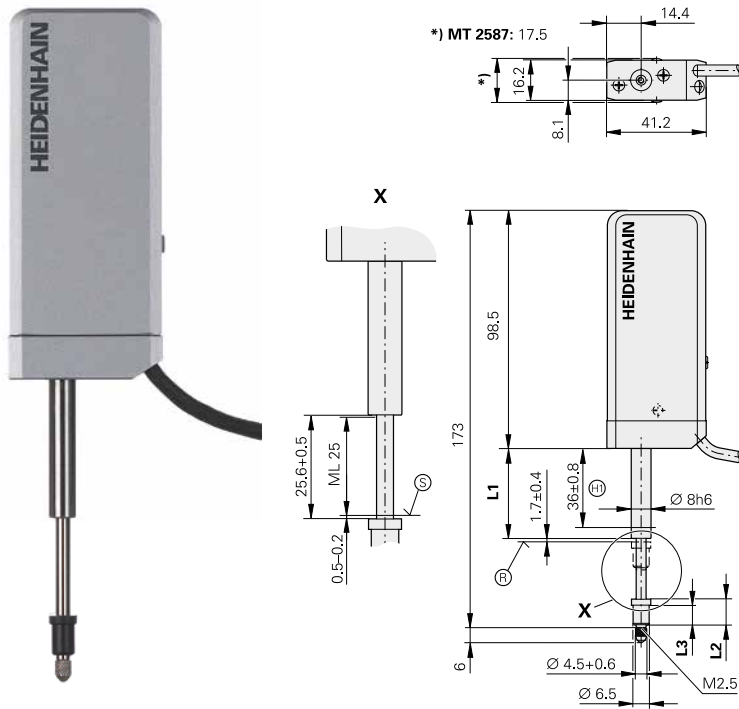





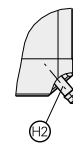

	MT 25x1	MT 2587
L1	370	41.0
L2	10.1	6.2
L3	8.1	4.2



MT 1287
MT 2587



mm

 Tolerancing ISO 8015
 ISO 2768 - m H
 < 6 mm: $\pm 0.2 \text{ mm}$

- ⊕ = Reference mark position
- ⊖ = Beginning of measuring length
- ⊕ = Clamping area
- ⊕ = Air connection for 2 mm tube

Mechanical data	MT 1271  TTL MT 1281  1 V _{PP}	MT 2571  TTL MT 2581  1 V _{PP}	MT 1287  1 V _{PP}	MT 2587  1 V _{PP}
Plunger actuation Position of plunger at rest	By cable or measured object Extended		Pneumatic Retracted	
Measuring standard	DIADUR phase grating on Zerodur glass ceramic; grating period 4 μm			
System accuracy	± 0.2 μm			
Position error per signal period	≤ ± 0.02 μm			
Short-range accuracy typically	0.03 μm	0.04 μm	0.03 μm	0.04 μm
Reference mark	≈ 1.7 mm below upper stop			
Measuring range	12 mm	25 mm	12 mm	25 mm
Working pressure	–		0.9 bar to 1.4 bars	
Radial force	≤ 0.8 N (mechanically permissible)			
Fastening	Clamping shank Ø 8h6			
Operating attitude	Any; for version without spring and with low gauging force: vertically downward			
Vibration 55 Hz to 2 000 Hz Shock 11 ms	≤ 100 m/s ² (EN 60068-2-6) ≤ 1 000 m/s ² (EN 60068-2-27)			
Operating temperature	10 °C to 40 °C; reference temperature 20 °C			
Protection EN 60 529	IP50		IP64 (with sealing air)	
Weight without cable	100 g	180 g	110 g	190 g

Electrical data	MT 1271 MT 2571	MT 128x MT 258x
Interface	 TTL	 1 V _{PP}
Integrated interpolation*	5-fold	10-fold
Signal period	0.4 μm	0.2 μm
Mech. permissible traversing speed	≤ 30 m/min	
Edge separation a at scanning frequency*/traverse speed¹⁾ 200 kHz ≤ 24 m/min 100 kHz ≤ 12 m/min 50 kHz ≤ 6 m/min 25 kHz ≤ 3 m/min	≥ 0.23 μs ≥ 0.48 μs ≥ 0.98 μs –	– ≥ 0.23 μs ≥ 0.48 μs ≥ 0.98 μs
Electrical connection* (Interface electronics integrated in connector)	Cable 1.5 m with D-sub connector (male), 15-pin	Cable 1.5 m with • D-sub connector (male), 15-pin • M23 connector (male), 12-pin
Cable length	≤ 30 m with HEIDENHAIN cable	
Voltage supply	5 V DC ± 0.5 V/< 160 mA (without load)	5 V DC ± 0.25 V/< 130 mA

* Please select when ordering

¹⁾ At the corresponding cutoff or scanning frequency

HEIDENHAIN-METRO

Incremental length gauges with $\pm 0.5 \mu\text{m}/\pm 1 \mu\text{m}$ accuracy

- Large measuring ranges
- For dimensional and positional measurement
- Ball-bush guided plunger

MT 60M



MT 60

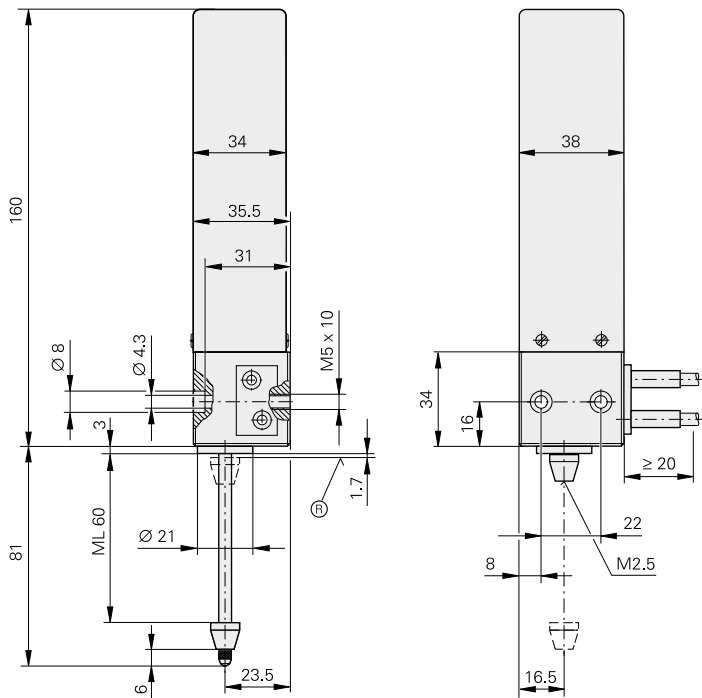

MT 101M



MT 101

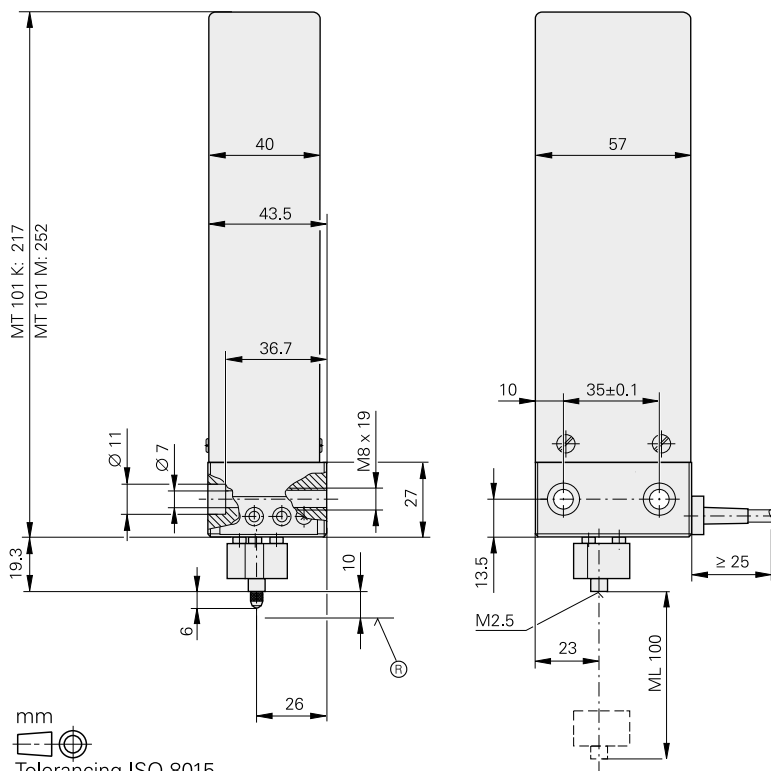

mm

 Tolerancing ISO 8015
 ISO 2768 - m H
 < 6 mm: ± 0.2 mm

⊕ = Reference mark position

Specifications	MT 60M	MT 101 M	MT 60K	MT 101 K
Plunger actuation	By motor		Via coupling with moving machine part	
Measuring standard	DIADUR grating on silica glass; grating period 10 µm			
System accuracy	± 0.5 µm	± 1 µm	± 0.5 µm	± 1 µm
Position error per signal period	≤ ± 0.1 µm			
Reference mark	≈ 1.7 mm from top	≈ 10 mm from top	≈ 1.7 mm from top	≈ 10 mm from top
Measuring range	60 mm	100 mm	60 mm	100 mm
Radial force mech. permissible	≤ 0.5 N	≤ 2 N	≤ 0.5 N	≤ 2 N
Fastening	Plane surface			
Operating attitude	Any	Vertically downward with SG 101V Horizontal with SG 101 H	Any	
Vibration 55 Hz to 2 000 Hz Shock 11 ms	≤ 100 m/s ² (EN 60068-2-6) ≤ 1 000 m/s ² (EN 60068-2-27)			
Operating temperature	10 °C to 40 °C; reference temperature 20 °C			
Protection EN 60529	IP50			
Weight without cable	700 g	1400 g	600 g	1200 g

Electrical data	MT 60M	MT 101 M	MT 60K	MT 101 K
Interface	~ 11 µA _{PP}			
Signal period	10 µm			
Measuring velocity	≤ 18 m/min	≤ 60 m/min	≤ 18 m/min	≤ 60 m/min
Electrical connection*	Cable 1.5 m with 15-pin D-sub connector (male) or with 9-pin M23 connector (male)			
Cable length	≤ 30 m with HEIDENHAIN cable			
Voltage supply	5 V DC ± 0.25 V			
Current requirement	< 120 mA	< 70 mA		

Required accessories*	For MT 60 M	For MT 101 M
Switch box	SG 60M	Vertical orientation: SG 101 V Horizontal orientation: SG 101 H
power supply unit	–	Required (see <i>Accessories</i>)

* Please select when ordering

¹⁾ Force required to move the plunger or of its weight

HEIDENHAIN-SPECTO

Incremental length gauges with $\pm 1 \mu\text{m}$ accuracy

- Very compact dimensions
- Splash-proof
- Ball-bush guided plunger

ST 1200

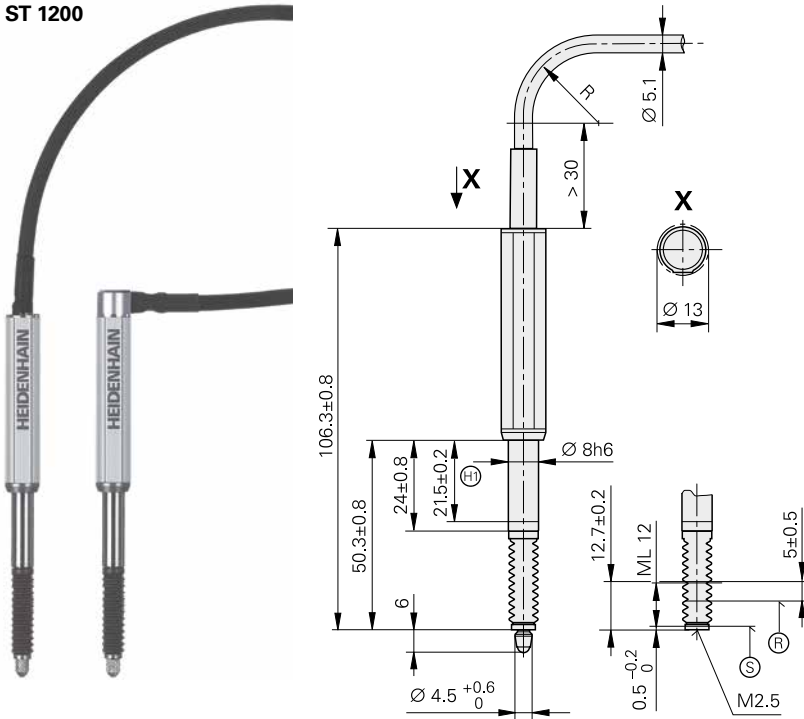

ST 3000

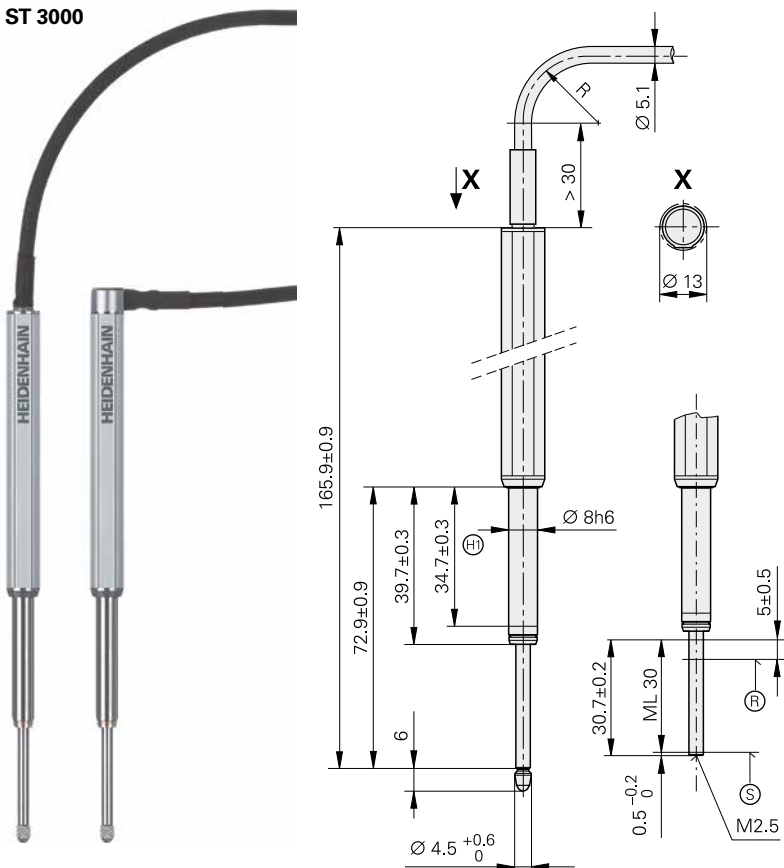

ST 12xx
ST 30xx

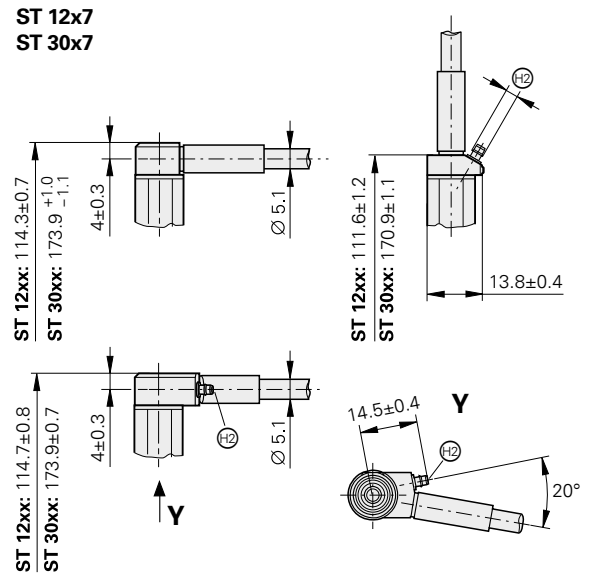











mm



Tolerancing ISO 8015
ISO 2768 - m H
< 6 mm: ± 0.2 mm

- Ⓢ = Reference mark position
- Ⓟ = Beginning of measuring length
- Ⓢ = Clamping area
- Ⓢ = Air connection for 2 mm tube

Mechanical data	ST 1278  ST 1288  1 V _{PP}	ST 3078  ST 3088  1 V _{PP}	ST 1277  ST 1287  1 V _{PP}	ST 3077  ST 3087  1 V _{PP}
Plunger actuation Position of plunger at rest	By measured object Extended		Pneumatic Retracted	
Measuring standard	DIADUR grating on glass; grating period 20 μm			
System accuracy	± 1 μm			
Position error per signal period	≤ ± 0.2 μm			
Short-range accuracy typically	0.3 μm			
Reference mark	≈ 5 mm below upper stop			
Measuring range	12 mm	30 mm	12 mm	30 mm
Working pressure	–		0.7 bar to 2.5 bars	0.8 bar to 2.5 bars
Radial force	≤ 0.8 N (mechanically permissible)			
Fastening	Clamping shank Ø 8h6			
Operating attitude	Any			
Vibration 55 Hz to 2 000 Hz Shock 11 ms	≤ 100 m/s ² (EN 60068-2-6) ≤ 1000 m/s ² (EN 60068-2-27)			
Operating temperature	10 °C to 40 °C; reference temperature 20 °C			
Protection EN 60529	IP67/IP64	IP 64		
Weight without cable	40 g	50 g	40 g	50 g

Electrical data	ST 127x ST 307x	ST 128x ST 308x
Interface	 TTL	 1 V _{PP}
Integrated interpolation*	5-fold	10-fold
Signal period	4 μm	2 μm
Edge separation a at scanning frequency*/traverse speed²⁾ 100 kHz ≤ 72 m/min ¹⁾ 50 kHz ≤ 60 m/min 25 kHz ≤ 30 m/min	≥ 0.48 μs ≥ 0.98 μs ≥ 1.98 μs	≥ 0.23 μs ≥ 0.48 μs ≥ 0.98 μs
Electrical connection*	Cable 1.5 m with D-sub connector (male), 15-pin (integrated interface electronics)	Cable 1.5 m with • D-sub connector (male), 15-pin • M23 connector (male), 12-pin
Cable outlet*	Axial or radial	
Cable length	≤ 30 m with HEIDENHAIN cable	
Voltage supply	5 V DC ± 0.5 V	
Current requirement	< 195 mA (without load)	< 55 mA

* Please select when ordering

¹⁾ Mechanically limited

²⁾ At the corresponding cutoff or scanning frequency

Accessories

Measuring contacts

Ball-type contact

Steel ID 202504-01
 Carbide ID 202504-02
 Ruby ID 202504-03

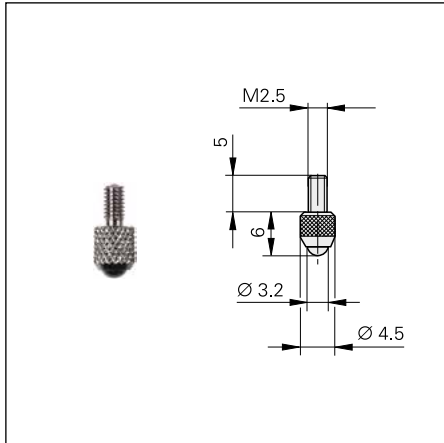

Domed contact

Carbide ID 229232-01

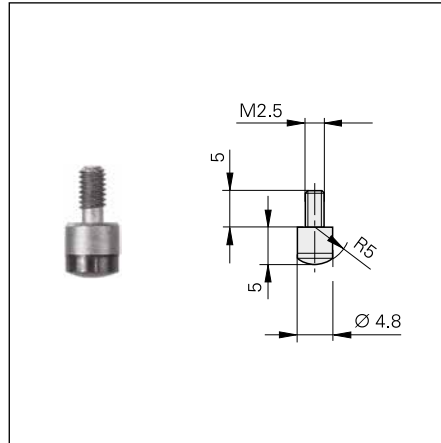

Flat contact

Steel ID 270922-01
 Carbide ID 202506-01

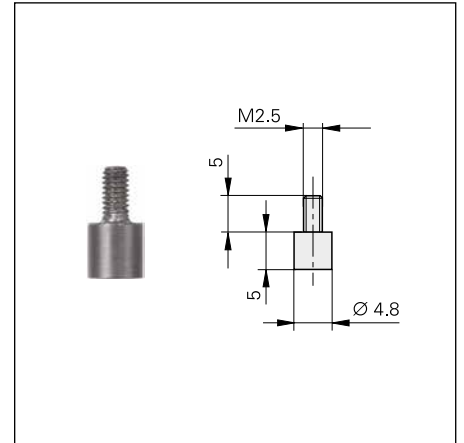

Pin-type contact

Steel ID 202505-01

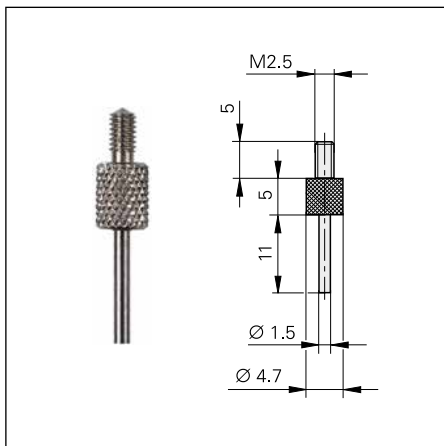

Knife-edge contact

Steel ID 202503-01

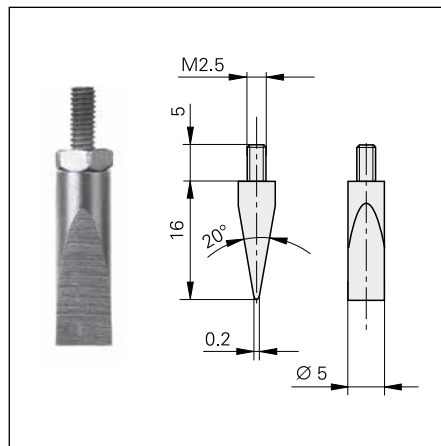

mm
 Tolerancing ISO 8015
 ISO 2768 - m H
 < 6 mm: ±0.2 mm

Roller contact, steel

For a low-friction contact with moving surfaces

Crowned ID 202502-03
 Cylindrical ID 202502-04

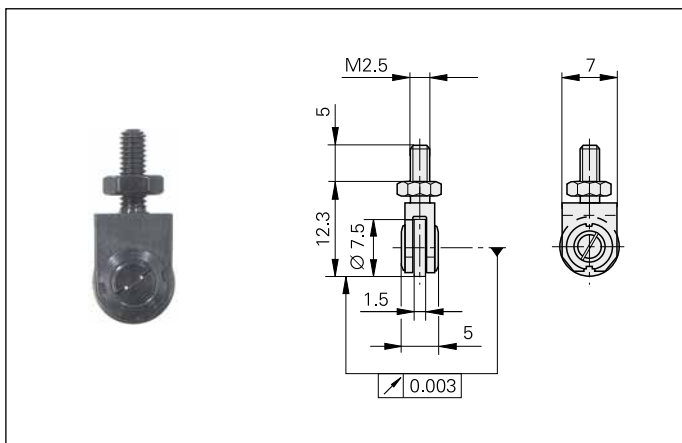

Adjustable contact, carbide

For exact parallel alignment to the measuring plate surface

Flat ID 202507-01
 Knife-edged ID 202508-01

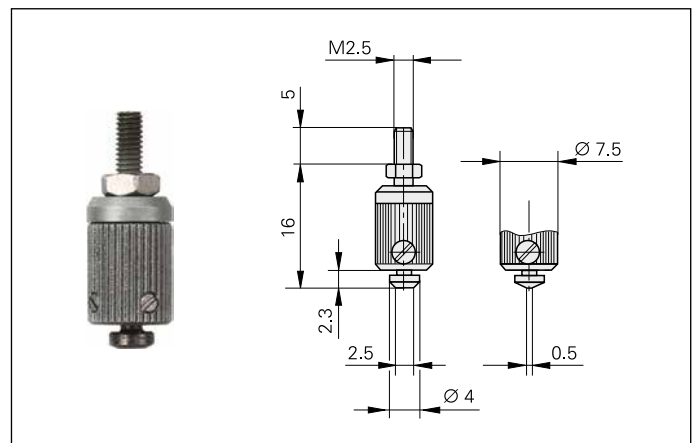

Switch boxes, coupling

Switch boxes for CT 2501, CT 6001, MT 60M, MT 101 M

Switch boxes are required for length gauges with motorized plunger actuation. The plunger is controlled through two push buttons or by external signal. The SG 25M and SG 60M switch boxes can adjust the gauging force in three stages.

SG 25M

ID 317436-01

SG 60M

ID 317436-02

SG 101V¹⁾

For the MT 101 M in vertical operation
ID 361140-01

SG 101H¹⁾

For the MT 101 M in horizontal operation
ID 361140-02

Connector (female) 3-pin

For external operation of the switch box
ID 340646-05

¹⁾ Separate power supply required

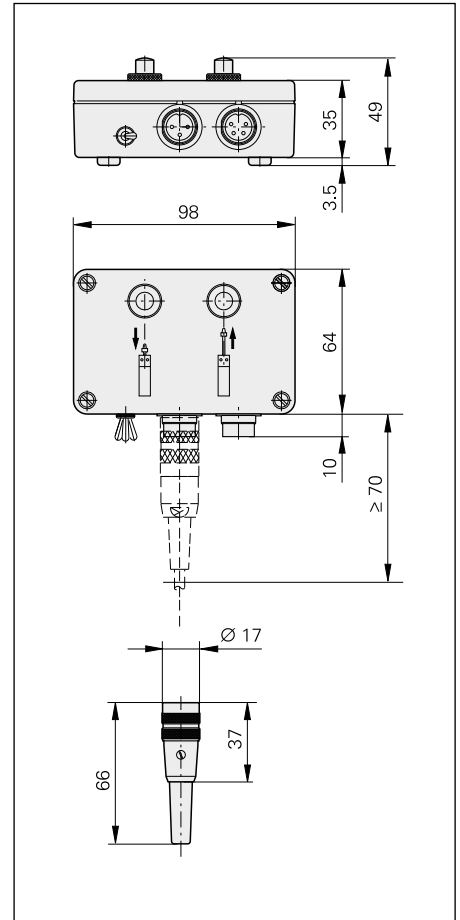

Power adapter for SG 101 V/H

An adapter to be connected to the switch box powers the MT 101 M.

Voltage range 100 V to 240 V AC
Exchangeable plug adapter
(U.S. and Euro connectors included in delivery)

ID 648029-01

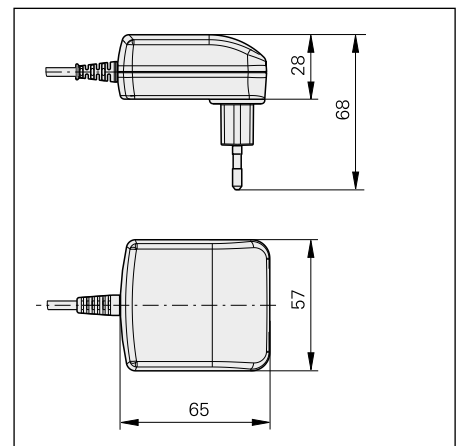

Coupling

For connecting the plunger of the length gauge (specifically for the MT 60K, MT 101 K, CT 2502 and CT 6002) to a moving machine element

ID 206310-01

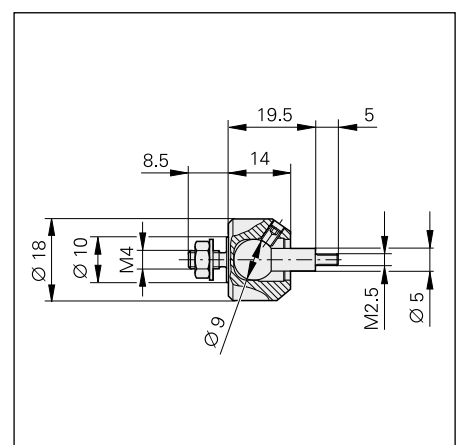

mm
Tolerancing ISO 8015
ISO 2768 - m H
< 6 mm: ±0.2 mm

Accessories for HEIDENHAIN-CERTO

Gauge stand

CS 200 gauge stand

For length gauges CT 2501 *
CT 6001

ID 221310-01

Overall height 350 mm
Base \varnothing 250 mm
Column \varnothing 58 mm
Weight 15 kg

*) With special holder

The flatness of the CS 200 is determined with the aid of a Fizeau interferometer.

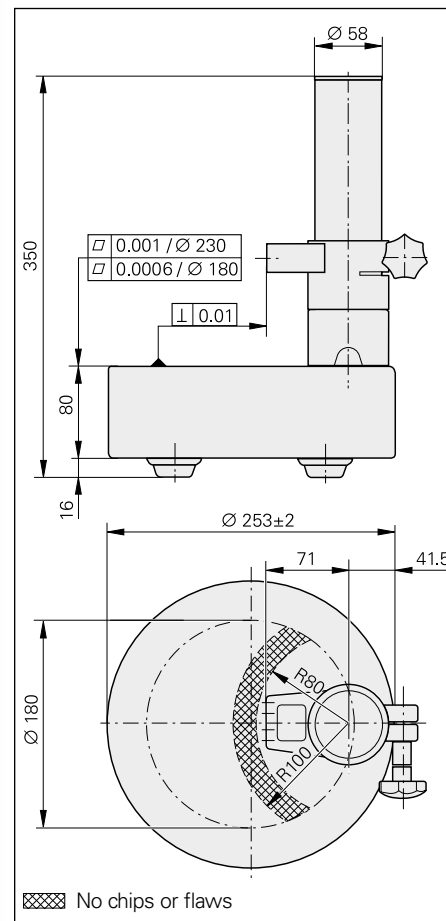

Holder for CS 200

For the CT 2501 with \varnothing 16 mm clamping shank

ID 324391-01

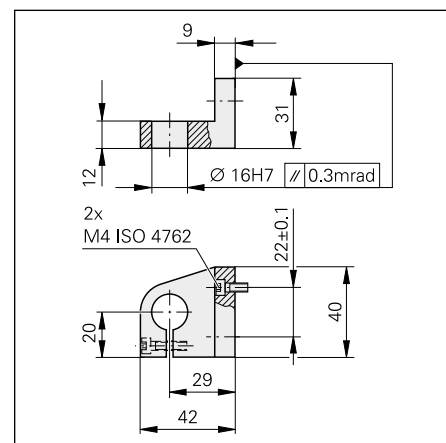

mm



Tolerancing ISO 8015
ISO 2768 - m H
< 6 mm: \pm 0.2 mm

Ceramic suction plate, diaphragm pump

Ceramic suction plate

Wear-resistant working surface with high surface quality specifically for inspecting gauge blocks

ID 223100-01

The gauge block (class 1 or 2)—or any other object with a plane surface—is drawn by suction onto the top of the ceramic plate. The ceramic plate is likewise drawn to the granite base and held in place through negative gauge base pressure.

Parts for connecting the ceramic suction plate with the diaphragm pump are among the items supplied:

Pressure tubing 3 m
T-joint
Connecting piece

Diaphragm pump

Source of suction for drawing the measured object and ceramic suction plate

Power consumption 20 W
Weight 2.3 kg
Line voltage 230 V AC/50 Hz
ID 754220-01

Line voltage 115 V AC/60 Hz
ID 754220-02

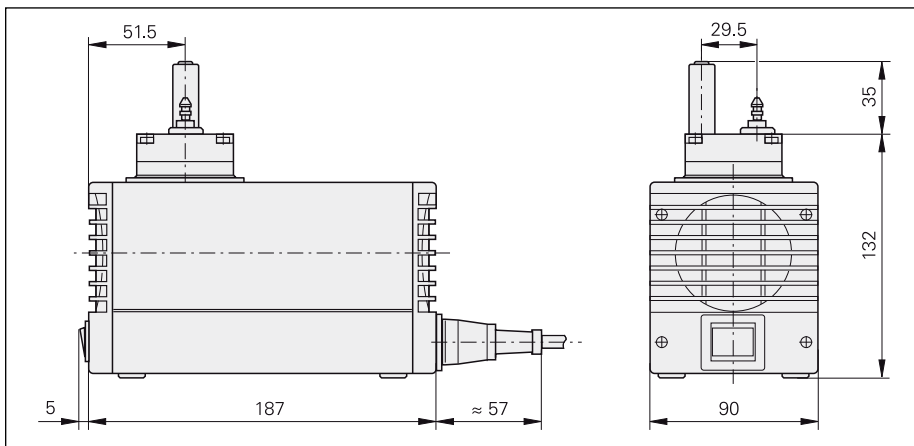
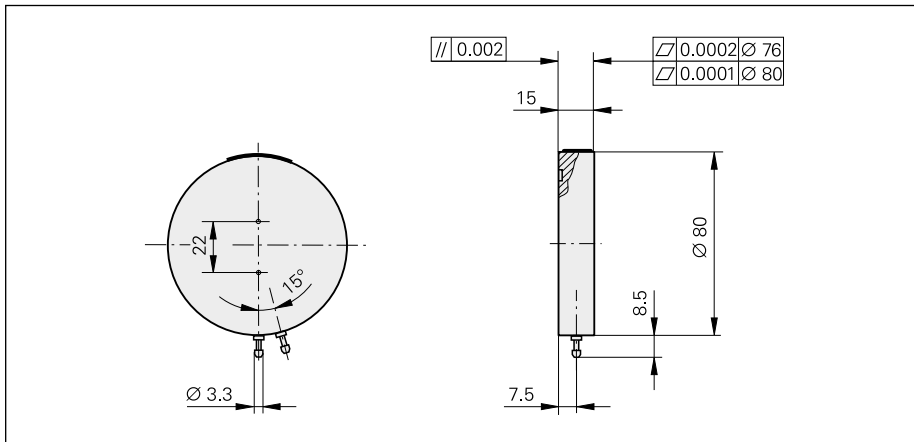

mm

 Tolerancing ISO 8015
 ISO 2768 - m H
 < 6 mm: ±0.2 mm

Accessories for HEIDENHAIN-ACANTO, HEIDENHAIN-METRO and HEIDENHAIN-SPECTO

Cable-type lifter, gauge stands

Cable lifter

For manual plunger actuation of MT 1200 and MT 2500. The integral pneumatic damping reduces the plunger extension speed to prevent bouncing, for example on very hard materials.

ID 257790-01

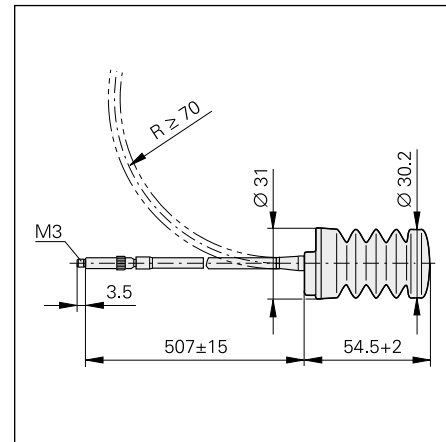

MS 200 gauge stand

For length gauges AT¹⁾
ST¹⁾
MT 1200¹⁾
MT 2500¹⁾
MT 60M
MT 101 M

ID 244154-01

Total height 346 mm
Base Ø 250 mm
Column Ø 58 mm
Weight 18 kg

¹⁾ With special holder

Holder for MS 200

For mounting the length gauges with Ø 8 mm clamping shank, e.g. AT, ST, MT 1200, MT 2500

ID 324391-02

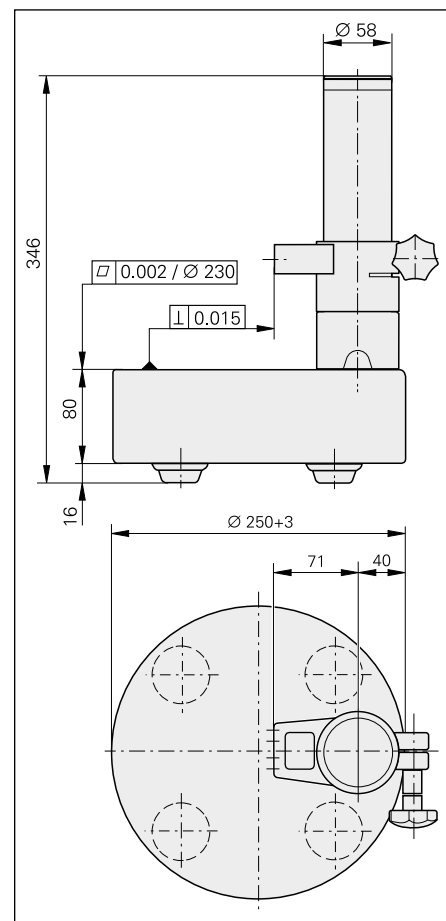

Clamping sleeve

For length gauges AT, ST
MT 1200
MT 2500

For fixing the length gauge reliably without overloading the 8h6 clamping shank.

Consisting of:

Sleeve, clamping screw

ID 386811-01 (1 piece)

ID 386811-02 (10 pieces)

mm



Tolerancing ISO 8015

ISO 2768 - m H

< 6 mm: ±0.2 mm

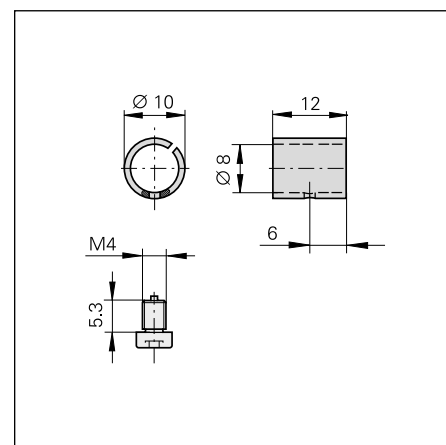

MS 45 gauge stand

For length gauges AT
ST
MT 1200
MT 2500

ID 202162-02

Overall height 196.5 mm
Measuring plate \varnothing 49 mm
Column \varnothing 22 mm
Weight 2.2 kg

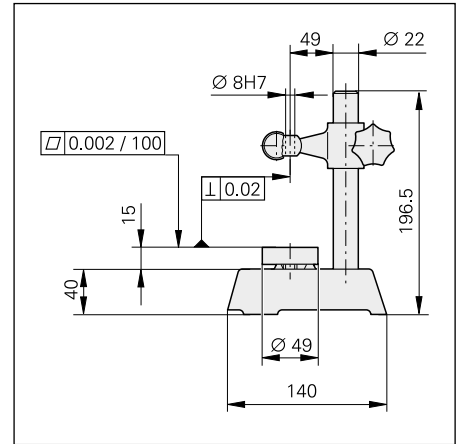

MS 100 gauge stand

For length gauges AT
ST
MT 1200
MT 2500
MT 60 M¹⁾
MT 101 M¹⁾

ID 202164-02

Overall height 385 mm
Measuring plate 100 mm x 115 mm
Column \varnothing 50 mm
Weight 18 kg

¹⁾ With special holder

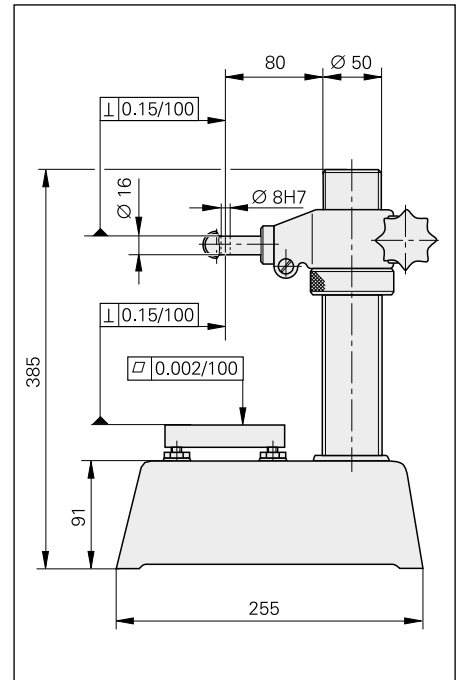

Holder for MS 100

For mounting the MT 60 M
ID 207479-01

For mounting the MT 101 M
ID 206260-01

mm
Tolerancing ISO 8015
ISO 2768 - m H
< 6 mm: ± 0.2 mm

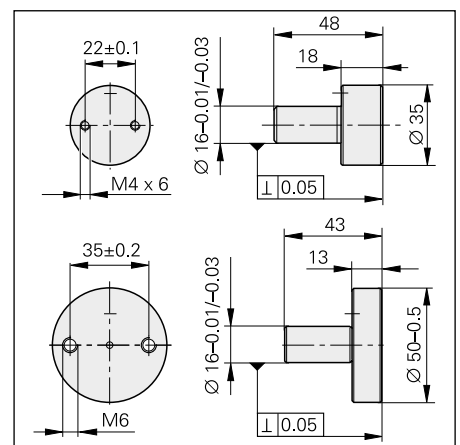

Interface electronics

Interface electronics from HEIDENHAIN adapt the encoder signals to the interface of the subsequent electronics. They are used when the subsequent electronics cannot directly process the output signals from HEIDENHAIN encoders, or if additional interpolation of the signals is necessary.

Input signals of the interface electronics

Interface electronics from HEIDENHAIN can be connected to encoders with sinusoidal signals of $1 V_{PP}$ (voltage signals) or $11 \mu A_{PP}$ (current signals). Encoders with the serial interfaces EnDat or SSI can also be connected to various interface electronics.

Output signals of the interface electronics

Interface electronics with the following interfaces to the subsequent electronics are available:

- TTL square-wave pulse trains
- EnDat 2.2
- DRIVE-CLiQ
- Fanuc Serial Interface
- Mitsubishi high speed interface
- Yaskawa Serial Interface
- Profibus

Interpolation of the sinusoidal input signals

In addition to being converted, the sinusoidal encoder signals are also interpolated in the interface electronics. This permits finer measuring steps and, as a result, higher control quality and better positioning behavior.

Formation of a position value

Some interface electronics have an integrated counting function. Starting from the last reference point set, an absolute position value is formed when the reference mark is traversed, and is transferred to the subsequent electronics.

Box design



Plug design



Version for integration



Top-hat rail design



Outputs		Inputs		Design – Protection class	Interpolation ¹⁾ or subdivision	Model		
Interface	Qty.	Interface	Qty.					
□ TTL	1	~ 1 V _{PP}	1	Box design – IP 65	5/10-fold	IBV 101		
					20/25/50/100-fold	IBV 102		
					Without interpolation	IBV 600		
					25/50/100/200/400-fold	IBV 660B		
				Plug design – IP 40	5/10/20/25/50/100-fold	APE 371		
				Version for integration – IP 00	5/10-fold	IDP 181		
		20/25/50/100-fold	IDP 182					
		~ 11 μA _{PP}	1			Box design – IP 65	5/10-fold	EXE 101
							20/25/50/100-fold	EXE 102
							Without/5-fold	EXE 602E
25/50/100/200/400-fold	EXE 660B							
Version for integration – IP 00					5-fold	IDP 101		
□ TTL/ ~ 1 V _{PP} Adjustable	2	~ 1 V _{PP}	1	Box design – IP 65	2-fold	IBV 6072		
					5/10-fold	IBV 6172		
					5/10-fold and 20/25/50/100-fold	IBV 6272		
EnDat 2.2	1	~ 1 V _{PP}	1	Box design – IP 65	≤ 16384-fold subdivision	EIB 192		
				Plug design – IP 40	≤ 16384-fold subdivision	EIB 392		
			2	Box design – IP 65	≤ 16384-fold subdivision	EIB 1512		
DRIVE-CLiQ	1	EnDat 2.2	1	Box design – IP 65	–	EIB 2391S		
Fanuc Serial Interface	1	~ 1 V _{PP}	1	Box design – IP 65	≤ 16384-fold subdivision	EIB 192F		
				Plug design – IP 40	≤ 16384-fold subdivision	EIB 392F		
			2	Box design – IP 65	≤ 16384-fold subdivision	EIB 1592F		
Mitsubishi high speed interface	1	~ 1 V _{PP}	1	Box design – IP 65	≤ 16384-fold subdivision	EIB 192M		
				Plug design – IP 40	≤ 16384-fold subdivision	EIB 392M		
			2	Box design – IP 65	≤ 16384-fold subdivision	EIB 1592M		
Yaskawa Serial Interface	1	EnDat 2.2 ²⁾	1	Plug design – IP 40	–	EIB 3391Y		
PROFIBUS-DP	1	EnDat 2.1; EnDat 2.2	1	Top-hat rail design	–	PROFIBUS Gateway		

¹⁾ Switchable

²⁾ Only LIC 4100 with 5 nm measuring step, LIC 2100 with 50 nm and 100 nm measuring steps

Evaluation electronics units

For measuring and testing tasks

Evaluation electronics from HEIDENHAIN combine measured value acquisition with intelligent, application-specific further processing. They are used in many metrological applications, ranging from simple measuring stations to complex inspection systems with multiple measuring points.

Evaluation units feature interfaces for various encoder signals. They include units with integrated display—which can be used independently—and units that require a PC for operation.

The overview table lists evaluation electronics for measuring and testing tasks. You can find comprehensive information, including on other evaluation units for 2-D and 3-D measuring tasks, on the Internet under www.heidenhain.de or in the product catalog *Evaluation Electronics for Metrology Applications*.

Digital readouts for manual machine tools optimally support the operator with cycles for milling, drilling and turning. You can find these digital readouts on the Internet at www.heidenhain.de or in the product catalog *Digital Readouts and Linear Encoders for Manually Operated Machine Tools*.



Unit with integrated display –
e.g. ND 2100G GAGE-CHEK



Modular design – MSE 1000



Table-top design – EIB 700



Version for integration – IK 220

ND 200

Evaluation unit for

- Measurement equipment
- Adjustment and inspection equipment
- SPC inspection stations

ND 1100 QUADRA-CHEK

Evaluation electronics for

- Positioning equipment
- Measuring fixtures

ND 2100G GAGE-CHEK

Evaluation electronics for

- Multipoint inspection apparatuses
- SPC inspection stations

MSE 1000

Modular evaluation electronics for

- Multipoint inspection apparatuses
- SPC inspection stations

EIB 700

Evaluation electronics for











- Testing stations
- Multipoint inspection apparatuses
- Mobile data acquisition

IK 220

Evaluation electronics for installation in computer systems with PCI interface for

- Measuring and testing stations

¹⁾ Optional for ND 287

Functions	Input		Interpolation or subdivision	Output Interface	Model
	Interface	Qty.			
<ul style="list-style-type: none"> • Metrological and statistical functions (sorting and tolerance checking, measurement series, SPC) • Second encoder¹⁾ for sum/difference display, temperature compensation 	 1 V _{PP}  11 μA _{PP} EnDat	1	4096-fold	RS-232-C/V-24 USB Ethernet ¹⁾	ND 280
		Up to 2			ND 287
<ul style="list-style-type: none"> • Measurement series with min./max. value storage • Connection for touch probe 	 1 V _{PP}  TTL	2	10-fold (at 1 V _{PP})	RS-232-C/V-24 USB	ND 1102
		3			ND 1103
		4			ND 1104
<ul style="list-style-type: none"> • Programming of up to 100 parts • Graphic display of measurement results • Sorting and tolerance checking using tolerance and warning limits • Measurement series with min./max. value storage • Entry of formulas and combinations • Functions for statistical process control (SPC) 	 1 V _{PP}  TTL EnDat	4	10-fold (at 1 V _{PP})	RS-232-C/V-24 USB	ND 2104 G
		8			ND 2108 G
<ul style="list-style-type: none"> • Modular design • Configurable as desired • Various interfaces • Fast communication with higher-level computer system • Universal outputs 	 1 V _{PP}  TTL EnDat Analog LVDT HBT	Up to 250	4096-fold	Ethernet	MSE 1000
<ul style="list-style-type: none"> • Precise position measurement up to 50 kHz updating rate • Programmable measured-value inputs • Internal and external measured-value triggers • Measured-value memory for approx. 250 000 measured values per channel • Connection over standard Ethernet interface to higher-level computer systems 	 1 V _{PP}	4	4096-fold	Ethernet	EIB 741 EIB 742
<ul style="list-style-type: none"> • Programmable measured-value inputs • Internal and external measured-value triggers • Measured-value memory for 8192 measured values per channel • Optional assemblies for encoder outputs and external inputs/outputs 	 1 V _{PP}  11 μA _{PP} EnDat SSI	2	4096-fold	PCI bus	IK 220

Interfaces

Incremental signals $\sim 11 \mu A_{PP}$

HEIDENHAIN encoders with $\sim 11 \mu A_{PP}$ interface provide current signals. They are intended for connection to ND position display units or EXE pulse-shaping electronics from HEIDENHAIN.

The sinusoidal **incremental signals** I_1 and I_2 are phase-shifted by 90° elec. and have signal levels of typically $11 \mu A_{PP}$. The illustrated sequence of output signals— I_2 lagging I_1 —applies for the retracting plunger.

The **reference mark signal** I_0 has an unambiguous assignment to the incremental signals.

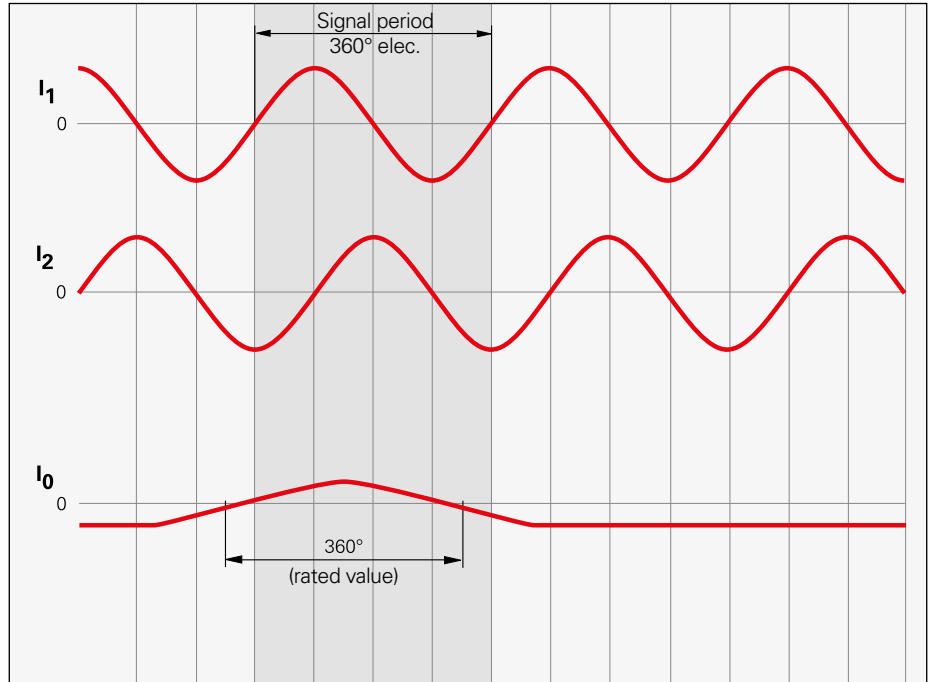

The *Interfaces of HEIDENHAIN Encoders* brochure, ID 1078628-xx, includes comprehensive descriptions of all available interfaces as well as general electrical information.

Pin layout

9-pin HEIDENHAIN connector					15-pin D-sub connector For ND 28x/PWM 20 or on encoder					
	Voltage supply				Incremental signals					
	3	4	housing	9	1	2	5	6	7	8
	4	2		6	1	9	3	11	14	7
	U_P	0V	External shield	Internal shield	I_{1+}	I_{1-}	I_{2+}	I_{2-}	I_{0+}	I_{0-}
	Brown	White	–	White/Brown	Green	Yellow	Blue	Red	Gray	Pink

U_P = Power supply
Vacant pins or wires must not be used!

Shield on housing
Color assignment applies only to extension cable.

Interfaces

Incremental signals $\sim 1 V_{PP}$

HEIDENHAIN encoders with $\sim 1 V_{PP}$ interface provide voltage signals that can be highly interpolated.

The sinusoidal **incremental signals** A and B are phase-shifted by 90° elec. and have amplitudes of typically $1 V_{PP}$. The illustrated sequence of output signals—with B lagging A—applies for the direction of motion shown in the dimension drawing.

The **reference mark signal** R has an unambiguous assignment to the incremental signals. The output signal might be somewhat lower next to the reference mark.

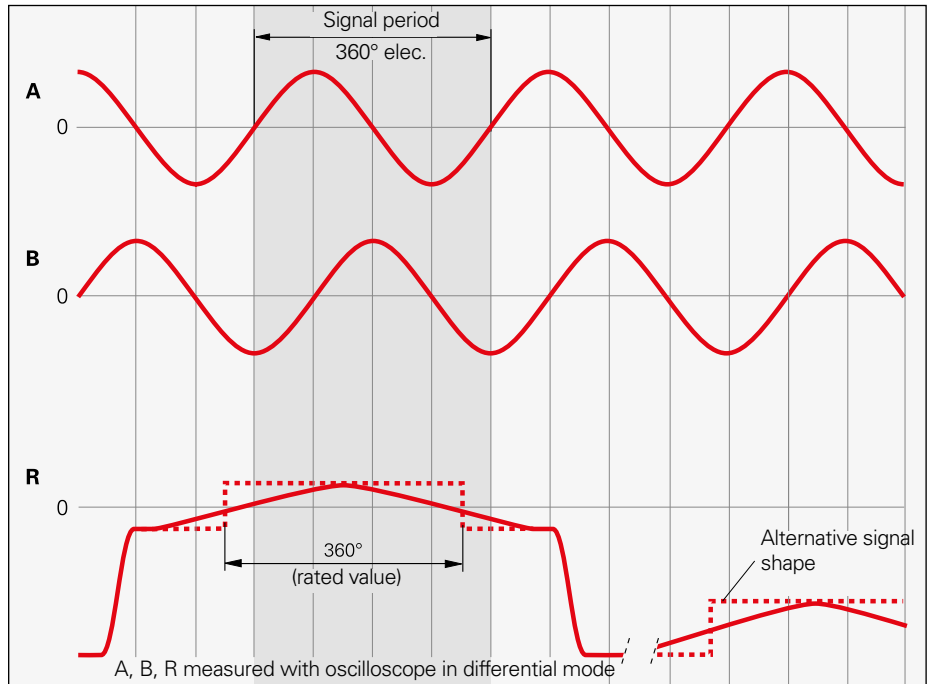

The *Interfaces of HEIDENHAIN Encoders* brochure, ID 1078628-xx, includes comprehensive descriptions of all available interfaces as well as general electrical information.

Pin layout

	12-pin coupling, M23				12-pin connector, M23				15-pin D-sub connector For ND 28x/PWM 20 or on encoder					
	Voltage supply				Incremental signals						Other signals			
	12	2	10	11	5	6	8	1	3	4	9	7	/	
	4	12	2	10	1	9	3	11	14	7	5/6/8/15	13	/	
	U_P	Sensor U_P	0V	Sensor 0V	A+	A-	B+	B-	R+	R-	Vacant	Vacant	Vacant	
	Brown/ Green	Blue	White/ Green	White	Brown	Green	Gray	Pink	Red	Black	/	Violet	Yellow	

Shield on housing; U_P = Power supply

Sensor: The sensor line is connected in the encoder with the corresponding power line.

Vacant pins or wires must not be used!

Color assignment applies only to extension cable.

Incremental signals

HEIDENHAIN encoders with TTL interface incorporate electronics that digitize sinusoidal scanning signals with or without interpolation.

The **incremental signals** are transmitted as the square-wave pulse trains U_{a1} and U_{a2} , phase-shifted by 90° elec. The **reference mark signal** consists of one or more reference pulses U_{a0} , which are gated with the incremental signals. In addition, the integrated electronics produce their **inverted signals** $\overline{U_{a1}}$, $\overline{U_{a2}}$ and $\overline{U_{a0}}$ for noise-proof transmission. The illustrated sequence of output signals—with U_{a2} lagging U_{a1} —applies to the direction of motion shown in the dimension drawing.

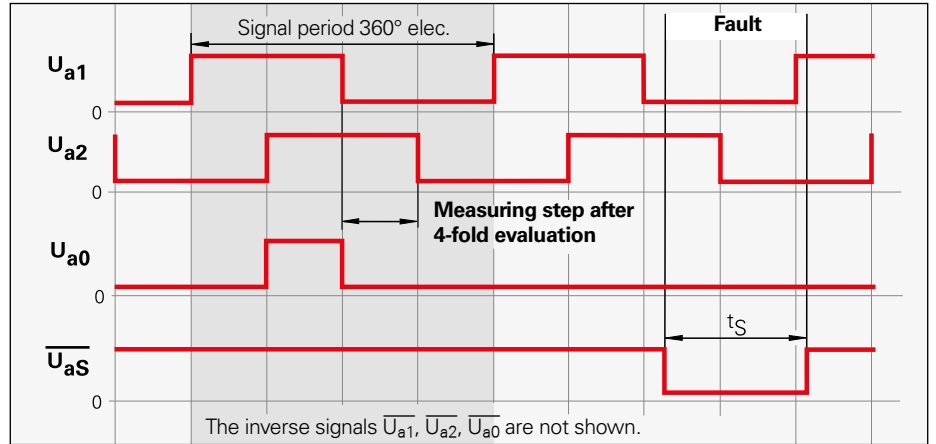

The **fault detection signal** $\overline{U_{aS}}$ indicates fault conditions such as an interruption in the supply lines, failure of the light source, etc.



The distance between two successive edges of the incremental signals U_{a1} and U_{a2} through 1-fold, 2-fold or 4-fold evaluation is one **measuring step**.

The *Interfaces of HEIDENHAIN Encoders* brochure, ID 1078628-xx, provides comprehensive descriptions of all available interfaces as well as general electrical information.

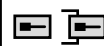
Pin layout

15-pin D-sub connector					12-pin HEIDENHAIN connector								
Voltage supply					Incremental signals						Other signals		
	12	2	10	11	5	6	8	1	3	4	7	/	9
	4	12	2	10	1	9	3	11	14	7	13	5/6/8	15
	U_P	Sensor U_P	0V	Sensor 0V	U_{a1}	$\overline{U_{a1}}$	U_{a2}	$\overline{U_{a2}}$	U_{a0}	$\overline{U_{a0}}$	$\overline{U_{aS}}$ ¹⁾	Vacant	Vacant ²⁾
	Brown/ Green	Blue	White/ Green	White	Brown	Green	Gray	Pink	Red	Black	Violet	–	Yellow

Shield on housing; U_P = Power supply

Sensor: The sensor line is connected in the encoder with the corresponding power line.

¹⁾ ERO 14xx: Vacant

²⁾ **Exposed linear encoders:** Switchover TTL/11 μ App for PWT

Vacant pins or wires must not be used!

Color assignment applies only to extension cable.

Interfaces

Position values

The EnDat interface is a digital, **bidirectional** interface for encoders. It is capable both of transmitting **position values** as well as transmitting or updating information stored in the encoder, or saving new information. Thanks to the **serial transmission method**, only **four signal lines** are required. The DATA data is transmitted in **synchronism** with the CLOCK signal from the subsequent electronics. The type of transmission (position values, parameters, diagnostics, etc.) is selected through mode commands that the subsequent electronics send to the encoder. Some functions are available only with EnDat 2.2 mode commands.



The *Interfaces of HEIDENHAIN Encoders* brochure, ID 1078628-xx, includes comprehensive descriptions of all available interfaces as well as general electrical information.

Ordering designation	Command set	Incremental signals
EnDat01	EnDat 2.1 or EnDat 2.2	With
EnDat21		Without
EnDat02	EnDat 2.2	With
EnDat22	EnDat 2.2	Without

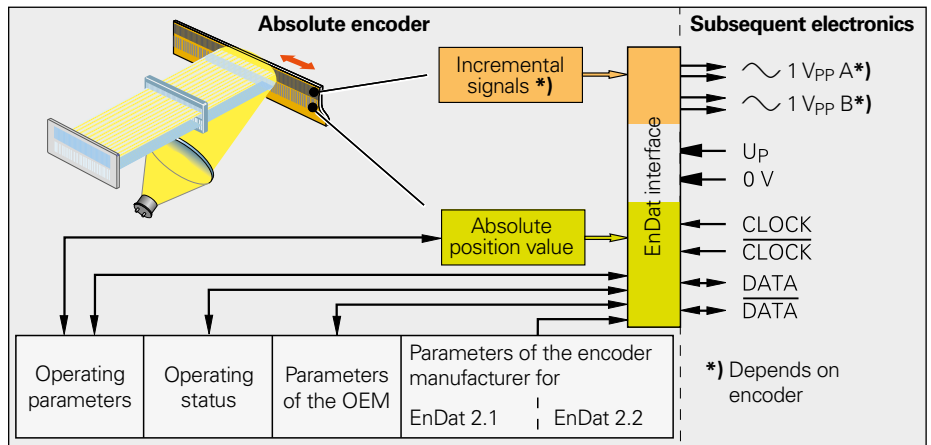
Versions of the EnDat interface

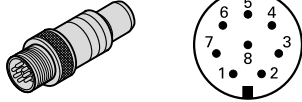
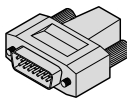
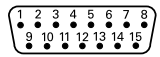

Pin layout

8-pin coupling, M12					15-pin D-sub connector, male For IK 215/PWM 20				
									
	Voltage supply				Absolute position values				
	8	2	5	1	3	4	7	6	
	4	12	2	10	5	13	8	15	
	UP	Sensor UP	0V	Sensor 0V	DATA	DATA	CLOCK	CLOCK	
	Brown/Green	Blue	White/Green	White	Gray	Pink	Violet	Yellow	

Cables and connecting elements

General information

Connector (insulated): Connecting element with coupling ring; available with male or female contacts (see symbols).

Symbols

M12

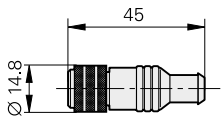

M12 right-angle connector

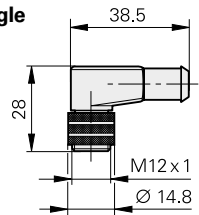

M23

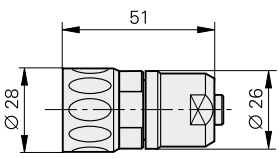

Coupling (insulated): Connecting element with external thread; available with male or female contacts (see symbols).

Symbols

M12

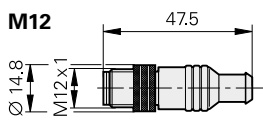

M23

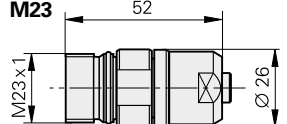

Mounted coupling with central fastening

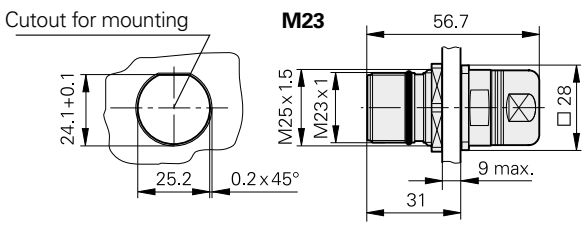

Mounted coupling with flange

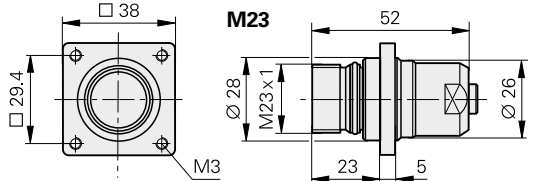

Flange socket: with external thread; permanently mounted on a housing, available with male or female contacts.

Symbols

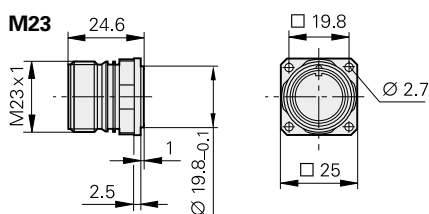

D-sub connector for HEIDENHAIN controls, counters and IK absolute value cards.

Symbols

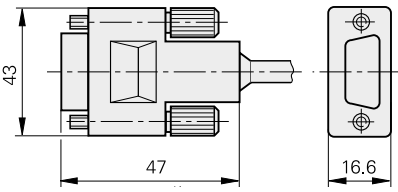

¹⁾ Interface electronics integrated in connector

The pins on connectors are **numbered** in the direction opposite to those on couplings or flange sockets, regardless of whether the connecting elements have

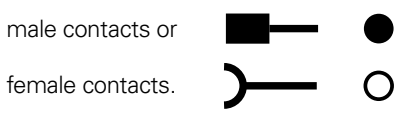

When engaged, the connections are **protected** to IP 67 (D-sub connector: IP 50; EN 60 529). When not engaged, there is no protection.





Accessory for flange sockets and M23 mounted couplings

Threaded metal dust cap
ID 219926-01

Accessory for M12 connecting element
Insulation spacer
ID 596495-01

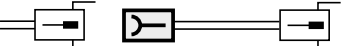
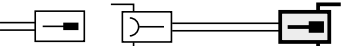
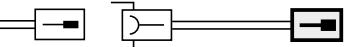
Cables and connecting elements

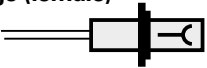
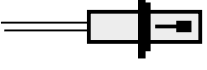
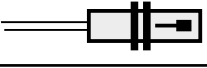





Connecting elements

		15-pin	
Connector on connecting cable to connector on encoder cable	D-sub connector, female for cable \varnothing 8 mm 	315650-14	
		12-pin	9-pin
Mating element on connecting cable to connector on encoder cable	Coupling (female) for cable \varnothing 8 mm 	291698-02	291698-01
Connector on cable for connection to subsequent electronics	Connector (male) for cable \varnothing 8 mm 	291697-08	291697-04
Coupling on connecting cable	Coupling (male) for cable \varnothing 8 mm 	291698-04	291698-24
Flange socket for mounting on subsequent electronics	Flange socket (female) 	315892-08	315892-06
Mounted couplings	With flange (female) \varnothing 8 mm 	291698-07	291698-06
	With flange (male) \varnothing 8 mm 	291698-31	–
	With central fastener (male) \varnothing 6 to 10 mm 	741045-01	–
Adapter \sim 1V _{pp} /11 μ A _{pp} For converting the 1 V _{pp} signals to 11 μ A _{pp} ; M23 connector (female, 12-pin) and M23 connector (male, 9-pin)		364914-01	–

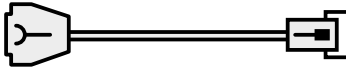
Connecting cables 1 V_{PP}, TTL, 11 μA_{PP}

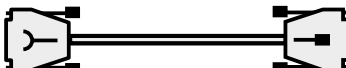
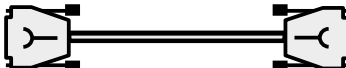
12-pin
M23

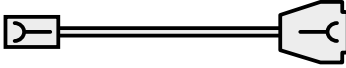
9-pin
M23

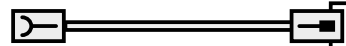
		1 V _{PP} , TTL		11 μA _{PP}
PUR connecting cable [3(2 x 0.14 mm ²) + (2 x 1 mm ²)]; A _P = 1 mm ²				
PUR connecting cable [6(2 x 0.19 mm ²)]; A _P = 0.19 mm ²				
PUR connecting cable [4(2 x 0.14 mm ²) + (4 x 0.5 mm ²)]; A _P = 0.5 mm ²		Ø 8 mm	Ø 6 mm ¹⁾	Ø 8 mm
Complete With D-sub connector (female) and M23 connector (male)		331693-xx	355215-xx	–
With one connector with D-sub connector (female), 15-pin		332433-xx	355209-xx	–
Complete With D-sub connector (female) and D-sub connector (male), 15-pin, for ND 28x, EIB 741; only 1 V _{PP} : ND 11xx, ND 12xx		335074-xx	355186-xx	–
Complete With D-sub connector (female) and D-sub connector (female), 15-pin, for ND 780, PT 880, IK 220		335077-xx	349687-xx	–
Cable only		816317-xx	816323-xx	–
Complete With M23 coupling (female) and D-sub connector (male), 15-pin, for ND 28x, EIB 741; only 1 V _{PP} : ND 11xx, ND 12xx		309784-xx	–	653231-xx
Complete With M23 coupling (female) and D-sub connector (male), 19-pin, for ND 11xx, ND 12xx (not 1 V _{PP})		617513-xx	–	716905-xx
Complete With M23 coupling (female) and D-sub connector (female), 15-pin, for ND 780, PT 880, IK 220		309783-xx	–	368172-xx
With one connector With M23 coupling (female)		298402-xx	–	309780-xx
Complete With M23 coupling (female) and M23 connector (male)		298400-xx	–	309774-xx

¹⁾ Max. cable length 9 m

A_P: Cross section of power supply lines





Cables and connecting elements

Connecting cables EnDat

8-pin

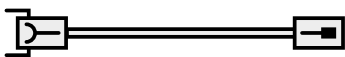
M12

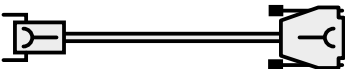
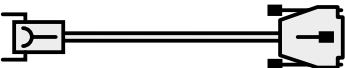
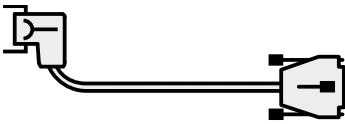
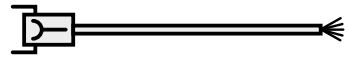
EnDat without incremental signals

PUR connecting cable [4 × (2 × 0.09 mm ²)]; A _P = 0.09 mm ²		Ø 6 mm	Ø 3.7 mm
Complete With connector (female) and coupling (male)		368330-xx	801142-xx ¹⁾
Complete With right-angle connector (female) and coupling (male)		373289-xx	801149-xx ¹⁾
Complete With connector (female) and D-sub connector (female), 15-pin, for TNC (position inputs)		535627-xx	–
Complete With connector (female) and D-sub connector (male), 15-pin, for IK 215, PWM 20, EIB 741, etc.		524599-xx	801129-xx ¹⁾
Complete With right-angle connector (female) and D-sub connector (male), 15-pin, for IK 215, PWM 20, EIB 741, etc.		722025-xx	801140-xx ¹⁾
With one connector With connector (female)		634265-xx	–
With one connector With right-angle connector (female)		606317-xx	–

¹⁾ Max. cable length 6 m

A_P: Cross section of power supply lines

Calibration according to DAkkS

As part of the quality management standard ISO 9001, inspection equipment relevant to quality must be monitored regularly, and must also be traceable to a national standard in concordance with the International System of Units (SI).

HEIDENHAIN supports its customers in this task with its own calibration laboratory for digital linear and angle encoders, which has been accredited since 1994.

The **calibration laboratory at HEIDENHAIN** operates according to DIN EN ISO/IEC 17025, and has been accredited by the German Accreditation Body (DAkkS).

HEIDENHAIN calibration certificates—granted by the accredited laboratory—document the traceability to the International System of Units (SI).

The DAkkS is a signatory to the multilateral agreement of the European co-operation for Accreditation (EA) and of the International Laboratory Accreditation Cooperation (ILAC) for the mutual recognition of calibration certificates.

Calibration certificates from HEIDENHAIN are recognized in most industrial countries.

The calibration certificate from HEIDENHAIN gives the user certainty about the accuracy of the encoder, and also certifies the traceability to the International System of Units (SI) necessary for ISO 9001.

The calibration laboratory at HEIDENHAIN is equipped for all **digital linear and angle encoders** where accuracy is of extreme importance:

- AT, CT, MT, ST and length gauges (also in conjunction with ND 28x, EXE or IBV subsequent electronics)
- LC, LF, LIDA, LIP, and LS linear encoders
- ECN, ROC, ROD, and RON angle encoders

Length gauges from HEIDENHAIN can be calibrated no matter what interface they have. If the measuring chain includes a subsequent electronics unit from HEIDENHAIN, this unit can also be included in the calibration.

The following are measured and certified:

- Deviation span with retracting plunger
- Deviation span in the part measuring span
- Repeatability with five measurements (extended plunger)



Deutsche
Akkreditierungsstelle
D-K-19057-01-00

Excerpt from a sample calibration certificate

		DR. JOHANNES HEIDENHAIN GmbH Dr.-Johannes-Heidenhain-Straße 5 83301 Traunreut, Germany Tel +49 8669 31-1157 FAX +49 8669 32-1157 E-mail: metz@heidenhain.de
akkreditiert durch die / accredited by the Deutsche Akkreditierungsstelle GmbH als Kalibrierlaboratorium im / as calibration laboratory in the Deutschen Kalibrierdienst		 Deutsche Akkreditierungsstelle D-K-19057-01-00
Kalibrierschein Calibration certificate		000000 D-K- 19057-01-00 2013-02
Gegenstand Object	Inkrementales Längenmessgerät	Dieser Kalibrierschein dokumentiert die Rückführung auf nationale Normale zur Darstellung der Einheiten in Übereinstimmung mit dem internationalen Einheitensystem (SI). Die DAkkS ist Unterzeichner der multilateralen Übereinkommen der European co-operation for Accreditation (EA) und der International Laboratory Accreditation Cooperation (ILAC) zur gegenseitigen Anerkennung der Kalibrierscheine. Für die Einhaltung einer angemessenen Frist zur Wiederholung der Kalibrierung ist der Benutzer verantwortlich. This calibration certificate documents the traceability to national standards, which realize the units of measurement according to the International System of Units (SI). The DAkkS is signatory to the multilateral agreements of the European co-operation for Accreditation (EA) and of the International Laboratory Accreditation Cooperation (ILAC) for the mutual recognition of calibration certificates. The user is obliged to have the object recalibrated at appropriate intervals.
Hersteller Manufacturer	HEIDENHAIN	
Typ Type	MT 2581	
Fabrikat/Serien-Nr. Serial number	8547396A	
Auftraggeber Customer	DR. JOHANNES HEIDENHAIN GmbH Dr.-Johannes-Heidenhain-Straße 5 83301 Traunreut	
Auftragsnummer Order No.	intern	
Anzahl der Seiten des Kalibrierscheines Number of pages of the certificate	4	
Datum der Kalibrierung Date of calibration	2013-02-20	
Dieser Kalibrierschein darf nur vollständig und unverändert weiterverbreitet werden. Auszüge oder Änderungen bedürfen der Genehmigung sowohl der Deutschen Akkreditierungsstelle GmbH als auch des anstellenden Kalibrierlaboratoriums. Kalibrierscheine ohne Unterschrift haben keine Gültigkeit. This calibration certificate may not be reproduced other than in full except with the permission of both the Deutsche Akkreditierungsstelle GmbH and the issuing laboratory. Calibration certificates without signature are not valid.		
Datum Date	Leiter des Kalibrierlaboratoriums Head of the calibration laboratory	Bearbeiter Person in charge
2013-02-20	Gerald Metz	Gerald Metz

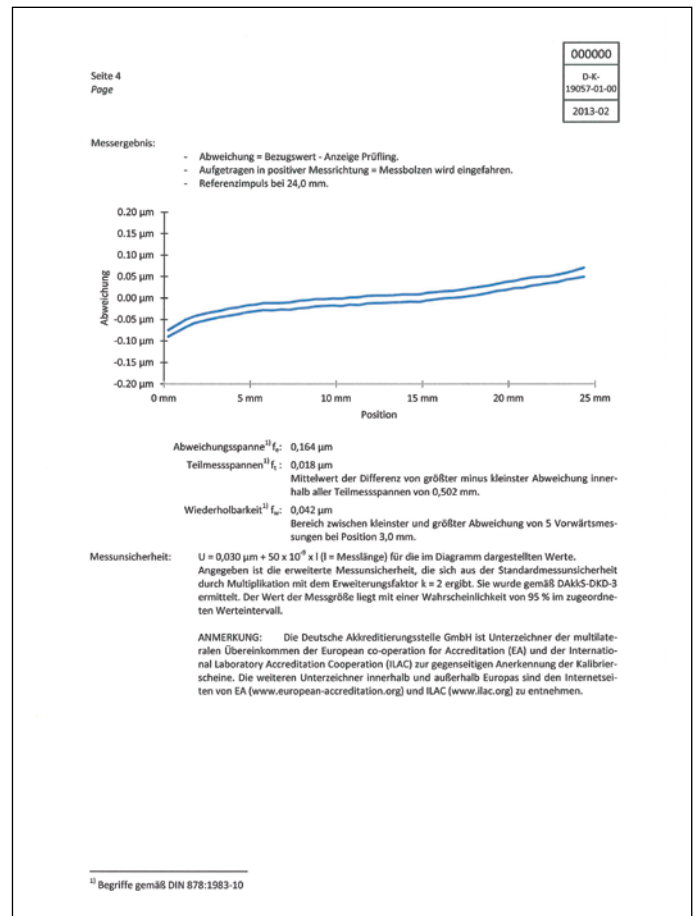

HEIDENHAIN

DR. JOHANNES HEIDENHAIN GmbH

Dr.-Johannes-Heidenhain-Straße 5

83301 Traunreut, Germany

☎ +49 8669 31-0

FAX +49 8669 32-5061

E-mail: info@heidenhain.de

www.heidenhain.de

Vollständige und weitere Adressen siehe www.heidenhain.de
For complete and further addresses see www.heidenhain.de

DE	HEIDENHAIN Vertrieb Deutschland 83301 Traunreut, Deutschland ☎ 08669 31-3132 FAX 08669 32-3132 E-Mail: hd@heidenhain.de	ES	FARRESA ELECTRONICA S.A. 08028 Barcelona, Spain www.farresa.es	PL	APS 02-384 Warszawa, Poland www.heidenhain.pl
	HEIDENHAIN Technisches Büro Nord 12681 Berlin, Deutschland ☎ 030 54705-240	FI	HEIDENHAIN Scandinavia AB 02770 Espoo, Finland www.heidenhain.fi	PT	FARRESA ELECTRÓNICA, LDA. 4470 - 177 Maia, Portugal www.farresa.pt
	HEIDENHAIN Technisches Büro Mitte 07751 Jena, Deutschland ☎ 03641 4728-250	FR	HEIDENHAIN FRANCE sarl 92310 Sèvres, France www.heidenhain.fr	RO	HEIDENHAIN Reprezentantă Romania Braşov, 500407, Romania www.heidenhain.ro
	HEIDENHAIN Technisches Büro West 44379 Dortmund, Deutschland ☎ 0231 618083-0	GB	HEIDENHAIN (G.B.) Limited Burgess Hill RH15 9RD, United Kingdom www.heidenhain.co.uk	RS	Serbia → BG
	HEIDENHAIN Technisches Büro Südwest 70771 Leinfelden-Echterdingen, Deutschland ☎ 0711 993395-0	GR	MB Milionis Vassilis 17341 Athens, Greece www.heidenhain.gr	RU	OOO HEIDENHAIN 115172 Moscow, Russia www.heidenhain.ru
	HEIDENHAIN Technisches Büro Südost 83301 Traunreut, Deutschland ☎ 08669 31-1345	HK	HEIDENHAIN LTD Kowloon, Hong Kong E-mail: sales@heidenhain.com.hk	SE	HEIDENHAIN Scandinavia AB 12739 Skärholmen, Sweden www.heidenhain.se
		HR	Croatia → SL	SG	HEIDENHAIN PACIFIC PTE LTD. Singapore 408593 www.heidenhain.com.sg
AR	NAKASE SRL. B1653AOX Villa Ballester, Argentina www.heidenhain.com.ar	HU	HEIDENHAIN Kereskedelmi Képviselet 1239 Budapest, Hungary www.heidenhain.hu	SK	KOPRETINA TN s.r.o. 91101 Trenčín, Slovakia www.kopretina.sk
AT	HEIDENHAIN Techn. Büro Österreich 83301 Traunreut, Germany www.heidenhain.de	ID	PT Servitama Era Toolsindo Jakarta 13930, Indonesia E-mail: ptset@group.gts.co.id	SL	NAVO d.o.o. 2000 Maribor, Slovenia www.heidenhain.si
AU	FCR Motion Technology Pty. Ltd Laverton North 3026, Australia E-mail: vicsales@fcrmotion.com	IL	NEUMO VARGUS MARKETING LTD. Tel Aviv 61570, Israel E-mail: neumo@neumo-vargus.co.il	TH	HEIDENHAIN (THAILAND) LTD Bangkok 10250, Thailand www.heidenhain.co.th
BE	HEIDENHAIN NV/SA 1760 Roosdaal, Belgium www.heidenhain.be	IN	HEIDENHAIN Optics & Electronics India Private Limited Chetpet, Chennai 600 031, India www.heidenhain.in	TR	T&M Mühendislik San. ve Tic. LTD. ŞTİ. 34775 Y. Dudullu – Ümraniye-Istanbul, Turkey www.heidenhain.com.tr
BG	ESD Bulgaria Ltd. Sofia 1172, Bulgaria www.esd.bg	IT	HEIDENHAIN ITALIANA S.r.l. 20128 Milano, Italy www.heidenhain.it	TW	HEIDENHAIN Co., Ltd. Taichung 40768, Taiwan R.O.C. www.heidenhain.com.tw
BR	DIADUR Indústria e Comércio Ltda. 04763-070 – São Paulo – SP, Brazil www.heidenhain.com.br	JP	HEIDENHAIN K.K. Tokyo 102-0083, Japan www.heidenhain.co.jp	UA	Gertner Service GmbH Büro Kiev 01133 Kiev, Ukraine www.heidenhain.ua
BY	GERTNER Service GmbH 220026 Minsk, Belarus www.heidenhain.by	KR	HEIDENHAIN Korea LTD. Gasan-Dong, Seoul, Korea 153-782 www.heidenhain.co.kr	US	HEIDENHAIN CORPORATION Schaumburg, IL 60173-5337, USA www.heidenhain.com
CA	HEIDENHAIN CORPORATION Mississauga, Ontario L5T2N2, Canada www.heidenhain.com	MX	HEIDENHAIN CORPORATION MEXICO 20290 Aguascalientes, AGS., Mexico E-mail: info@heidenhain.com	VE	Maquinaria Diekmann S.A. Caracas, 1040-A, Venezuela E-mail: purchase@diekmann.com.ve
CH	HEIDENHAIN (SCHWEIZ) AG 8603 Schwerzenbach, Switzerland www.heidenhain.ch	MY	ISOSERVE SDN. BHD. 43200 Balakong, Selangor E-mail: isoserve@po.jaring.my	VN	AMS Co. Ltd HCM City, Vietnam E-mail: davidgoh@amsvn.com
CN	DR. JOHANNES HEIDENHAIN (CHINA) Co., Ltd. Beijing 101312, China www.heidenhain.com.cn	NL	HEIDENHAIN NEDERLAND B.V. 6716 BM Ede, Netherlands www.heidenhain.nl	ZA	MAFEMA SALES SERVICES C.C. Midrand 1685, South Africa www.heidenhain.co.za
CZ	HEIDENHAIN s.r.o. 102 00 Praha 10, Czech Republic www.heidenhain.cz	NO	HEIDENHAIN Scandinavia AB 7300 Orkanger, Norway www.heidenhain.no		
DK	TPTEKNIK A/S 2670 Greve, Denmark www.tp-gruppen.dk	PH	Machinebanks Corporation Quezon City, Philippines 1113 E-mail: info@machinebanks.com		

