

Starrett®

PKG08805- UMDFC

TRUST IS IN THE NAME

User Manual

READ THIS MANUAL BEFORE USING THE INSTRUMENT

**ANTES DE UTILIZAR EL INSTRUMENTO,
LEA ATENTAMENTE ESTE MANUAL**

LIRE CE MANUEL AVANT D'UTILISER L'INSTRUMENT

**LEIA ATENTAMENTE ESTE MANUAL ANTES
DE UTILIZAR O INSTRUMENTO**

使用仪器前请阅读本操作手册

**DIESES HANDBUCH VOR DER VERWENDUNG
DES MESSGERÄTS LESEN**

**LEGGERE ATTENTAMENTE QUESTO MANUALE PRIMA
DI UTILIZZARE QUESTO STRUMENTO**

Starrett®

DFC DIGITAL FORCE CONTROLLER

USER MANUAL

TABLE OF CONTENTS

Page		Page		Page				
	General Safety Precautions	5	5.1.3	Peak Compression Mode	23	5.8.1.5	Transmit (XMIT) Tolerance	40
	Warnings	5	5.1.4	Average Mode	23	5.8.1.6	Transmit Tolerances	42
1.0	Introduction	8	5.2	Averaging Setup	23	5.8.2	Display Setup	42
2.0	Specifications and Dimensions	8	5.2.1	Setting Duration	24	5.8.2.1	Using Auto Off	42
3.0	Force Gage Fundamentals	9	5.2.2	Setting Start Force	24	5.8.2.2	Adjusting Backlight Intensity	43
3.1	Keypad and Navigation	9	5.2.3	Using Sounds	24	5.8.2.3	Changing Display Orientation (Flip Feature)	43
3.1.1	On/Off/ Menu Key	10	5.2.4	Using Shortfall	24	5.8.2.4	Radix Setup	44
3.1.2	Zero Key	10	5.2.5	Coefficient of Friction	25	5.8.3	Filter Setup	44
3.1.3	Softkey 1	10	5.2.5.1	Kinetic COF	25	5.8.4	ABOUT View	45
3.1.4	Softkey 2	10	5.2.5.2	Static COF	25	5.8.5	Using Passcode	45
3.2	Display Layout	10	5.2.5.3	Initial Delay	26	5.8.6	Selecting Display LANGUAGE	46
3.2.1	Primary Display	12	5.2.5.4	Sled Mass	26	6.0	DFC Accessories	46
3.2.2	Secondary Display	12	5.3	Selecting Units of Measure	26	7.0	Cable Pinout	49
3.2.3	Direction Symbols	12	5.3.1	User Units Label	27			
3.2.4	Tolerance Display	12	5.3.2	User Units Scalar	27			
3.2.5	Bargraph	12	5.3.3	User Units in/mm	27			
3.2.6	Softkey Labels	13	5.4	Memory Setup	28			
3.2.7	Operating Modes	13	5.4.1	Display Memory	28			
3.2.8	UnitsofMeasure	13	5.4.2	Clear Memory	28			
3.2.9	Display Orientation (Flip)	13	5.4.3	Export Memory	29			
3.3	Cablesand Communications	14	5.4.3.1	Export Results	29			
3.3.1	USB Cable (Part No. L1-USB)	14	5.5	Tests Setup (DFC Controller Mode)	29			
3.3.2	RS-232 Cable (Part No. L1-RS232)	14	5.5.1	Test Methods	29			
3.3.3	Control Cable (Part No. L1-CONTROL)	14	5.5.2	LOAD Limit Test Method	30			
3.4	Test Frame Operation	14	5.5.2.1	Load Limit TYPE	30			
3.4.1	Using the FMM Digital Test Frame	14	5.5.2.2	Load Limit TARGET	30			
3.4.2	Using the MTL Manual Test Frame	14	5.5.2.3	Load Limit TEST SPEED	30			
3.4.3	Using the MTH Manual Test Frame	15	5.5.3	Distance Limit Test Method	31			
3.5	Load Sensor Measurement	15	5.5.3.1	Distance Limit TYPE	31			
3.6	Using Accessories	15	5.5.3.2	Distance Limit TARGET	31			
3.6.1	Standard Gage Accessories	15	5.5.3.3	Distance Limit Test SPEED	31			
3.6.2	Clevis Accessories	16	5.5.4	Break Limit Test Method	32			
4.0	Force Gage Operation	16	5.5.4.1	Break Limit TYPE	32			
4.1	Power On/Off	16	5.5.4.2	Break MINIMUM BREAK	32			
4.1.1	Using Automatic Off	16	5.5.4.3	Break % DROP	32			
4.1.2	Charging the Battery	16	5.5.4.4	Break Test SPEED	33			
4.2	Gage Display Formats	16	5.5.5	Using Auto Zero	33			
4.2.1	Real Time Display	16	5.5.6	Using Return to Zero	33			
4.2.2	Peak Tension Display	17	5.5.7	Using Auto Save	33			
4.2.3	Peak Compression Display	17	5.5.8	TEST Mode Error Messages	34			
4.2.4	Tolerance Display	17	5.6	Tolerance Setup (Pass-Fail Results)	36			
4.2.5	Statistics Display	17	5.6.1	Setting Up Tolerance Limits	36			
4.2.6	Average Display	18	5.6.2	Using Tolerance with Tests Setup	37			
4.2.7	Coefficient of Friction Display	18	5.6.3	Using Tolerance with Coefficient of Friction	37			
4.2.8	Memory Display	18	5.6.4	Using Sounds with Tolerance Results	38			
4.2.9	Overload Condition Display	18	5.7	Keys	38			
4.2.10	About Display	18	5.7.1	SEND Function	38			
4.3	Controller Display Formats	19	5.7.2	MODE Function	38			
4.3.1	Load Limit Test Method Display	19	5.7.3	STATS (Statistics) Function	38			
4.3.2	Distance Limit Test Method Display	19	5.7.4	SAVE Function	38			
4.3.3	Break Limit Test Method Display	19	5.7.5	UNITS Function	38			
4.4	Saving Results	20	5.7.6	START/STOP Function (Used with TESTS)	38			
4.5	Exporting Results	20	5.7.7	Mapping Softkey 1	39			
4.6	Managing Gage Memory	20	5.7.8	Mapping Softkey 2	39			
4.7	Viewing Memory	21	5.8	Settings	39			
4.7.1	Viewing Single Results	21	5.8.1	Communications	39			
4.7.2	Viewing TESTS Result L-D Pairs	21	5.8.1.1	Using Bluetooth®	40			
5.0	Force Gage Setup	22	5.8.1.2	Using USB	40			
5.1	Selecting Operating Mode	22	5.8.1.3	Using RS-232	40			
5.1.1	Real Time Mode	22	5.8.1.4	Transmit (XMIT) Units	40			
5.1.2	Peak Tension Mode	23						

PRODUCT WARRANTY

Starrett force measurement products carry a 3-year (from date of purchase) warranty against defects in material and workmanship (parts and labor), subject to factory inspection.

Starrett will repair or replace, at its option, any part or parts found to be defective in workmanship or material. Starrett warrants repaired or replaced parts for the balance of the original warranty period or 90 days, whichever is longer. Parts returned to the factory under warranty will be repaired at no charge. Freight charges to the factory will be paid by the customer. Return freight charges to the customer will be paid by Starrett.

This warranty does not cover damages from such causes as abuse, accident, neglect, fire or freight damage. It does not apply to defects resulting from modifications made by the customer or improper use of the system or its components.

DISCLAIMER OF LIABILITIES

Starrett shall have no liability or responsibility to the customer or any other person or entity with respect to any liability, loss or damage caused or alleged to be caused directly or indirectly by this documentation, or the hardware described in it. This includes but is not limited to any interruption of service, loss of business or anticipatory profits, or consequential damages resulting from the use or operation of hardware or equipment.

GENERAL SAFETY PRECAUTIONS

Force measurement systems are potentially hazardous. Prior to operating your testing system, Starrett recommends that you read and understand the instruction manuals for your system and components and that you receive training on the proper use of this equipment from your authorized Starrett representative.

Observe all warnings and cautions identified in this manual for your equipment. A warning identifies a function that may lead to injury or death. A caution identifies a hazard that may lead to damage to equipment or loss of data.

Starrett products, to the best of our knowledge, comply with various national and international safety standards as they apply to material and force measurement testing. This Starrett product has been tested and found to comply with the following recognized standards:

- EN61010-1 Safety Requirements for Electrical Equipment
- EN61000-6-3 EMC Generic Emissions Standard
- EN61000-6-1 EMC Generic Immunity Standard
- Starrett also certifies that this product complies with all relevant EU directives and carries the CE mark.

ELECTROMAGNETIC COMPATIBILITY

Your DFC Force Gage is designed to comply with International Electromagnetic Compliance (IEC) standards.

To ensure reproduction of this EMC performance, connect this equipment to a low impedance ground connection. Typical suitable connections are a ground spike or the steel frame of a building.

WARNINGS

EMERGENCY STOP (FMM SYSTEM APPLICATIONS)

Press the emergency stop button whenever you feel there is an unsafe condition during a test. The emergency stop button removes power to the motor drive system causing the crosshead to stop.

FLYING DEBRIS

Eye protection, protective clothing and splinter/safety shields should be used whenever any possibility exists of a hazard from the failure of a sample, assembly or structure under test. Due to the wide range of materials that may be tested and that may result in a failure which may cause bodily injury, the precautions and preventative methods taken prior to testing is entirely the responsibility of the owner and the user of the equipment.

CRUSH HAZARD (FMM SYSTEM APPLICATIONS)

Always use caution when installing or removing apparatus and your sample material between the frame's crosshead and the base. A potential pinch/crush hazard exists. Keep clear of the testing fixture, and particularly the jaw faces at all times. Keep clear of the crosshead during movement. If available, always make sure the Grip Load feature is enabled. This will stop inadvertent crosshead operation if in manual mode. Always ensure that other personnel cannot operate the system while you are working within the test fixture area.

ELECTRICAL HAZARD

Disconnect equipment from the electrical power supply before removing any electrical safety covers. Disconnect power when replacing fuses. Never reconnect power while the covers are removed. Never operate the system with protective covers removed.

ROTATING MACHINERY HAZARD (FMM SYSTEM APPLICATIONS)

Always disconnect power before removing covers that protect the user from the internal rotating mechanisms. If maintenance to the drive mechanism is required, and power is needed to perform maintenance to the drive system, maintenance should be performed by an authorized Starrett representative who has received factory training on performing such procedures.

DFC DIGITAL FORCE CONTROLLER



THIS IS A STARRETT USER GUIDE FOR THE DFC DIGITAL FORCE CONTROLLER.

ALL SPECIFICATIONS IN THIS DOCUMENT ARE CORRECT AT TIME OF PRODUCTION AND ARE SUBJECT TO CHANGE. PLEASE CONTACT STARRETT FOR FURTHER INFORMATION.

1.0 INTRODUCTION

Thank you for choosing the DFC Force Gage.

The DFC may be used as a classic digital force gage. It may also be used as a digital controller when connected to the FMM Series digital force tester.

The DFC, as a controller, is the only gage available that lets you setup an automated test, including the operating parameters of the force tester. Configure speed and distance limits through the DFC.

This manual provides an overview and general instructions of how to use the DFC Force Gage, both as a traditional force gage and as a digital controller when connected to the FMM Digital Test Frame.



2.0 SPECIFICATIONS

DFC Advanced Force Gage	
Specification	DFC
Accuracy, Full Scale	0.001
Data Sampling (Hz)	25000
Display Resolution	10,000:1
Safe Overload, Full Scale	2
Maximum Tare	0.1
Communications	
Bluetooth®	Yes
USB 2.0	Yes
RS-232	Yes
Digital I/O	2 channels
Memory, maximum results saved in gage	99
Operating Mode	
Machine Control ¹	Yes
Real Time	Yes
Peak Compression	Yes
Peak Tension	Yes
Load Limit	Yes
Break Limit	Yes
Load Average	Yes
Load-Time Average	Yes
Cyclic Count (99,999 maximum)	Yes
Cyclic Duration (27 hours)	Yes
Hold Duration (27 hours)	Yes
Switch Test (Electrical Contact Closure)	Yes
Coefficient of Friction	Yes
Power, Environmental	
Battery Type	Lithium Ion
Battery Life, typical @ 20% brightness	>30 hours
Charge Time, using 110/240V Mains	<3hours
Display	OLED 320 x 240
Operating Temperature	40°F to 110°F (4°C to 43°C)
Thread, for adapters (Metric)	M6, M10
Instrument Weight (approx.)	3 lbs (1.36 kgs)

NOTES

- Machine control is exclusive to the DFC. When connected to the FMM Digital Force Tester, configuration of force gage and tester is performed through the gage.

DFC - Advanced Force Controller										
Model No.	Load Capacity					Safe Overload % Full Scale	Full Scale Deflection		Thread mm	Accessory Kit
	N	KGF	LBF	OZF	GF		in	mm		
DFC-2	10	1	2	32	900	200	0.013	0.33	M6 x 1-6H	SPK-FG-A
DFC-5	25	2	5	80	2200	200	0.007	0.18	M6 x 1-6H	SPK-FG-A
DFC-10	50	5	10	160	5000	200	0.006	0.15	M6 x 1-6H	SPK-FG-S
DFC-20	100	10	20	320	9000	200	0.008	0.20	M6 x 1-6H	SPK-FG-S
DFC-50	250	25	50	800	23000	200	0.015	0.39	M6 x 1-6H	SPK-FG-S
DFC-100	500	50	110	1600	45000	200	0.024	0.60	M6 x 1-6H	SPK-FG-S
DFC-200	1000	100	225	-	-	200	0.021	0.54	M6 x 1-6H	SPK-FG-M
DFC-500	2500	250	550	-	-	200	0.028	0.70	M10 x 1.5-5H	SPK-FG-L

NOTES

Load measurement accuracy is $\pm 0.1\%$ of load cell capacity. Display resolution is 10,000:1.

DIMENSIONS

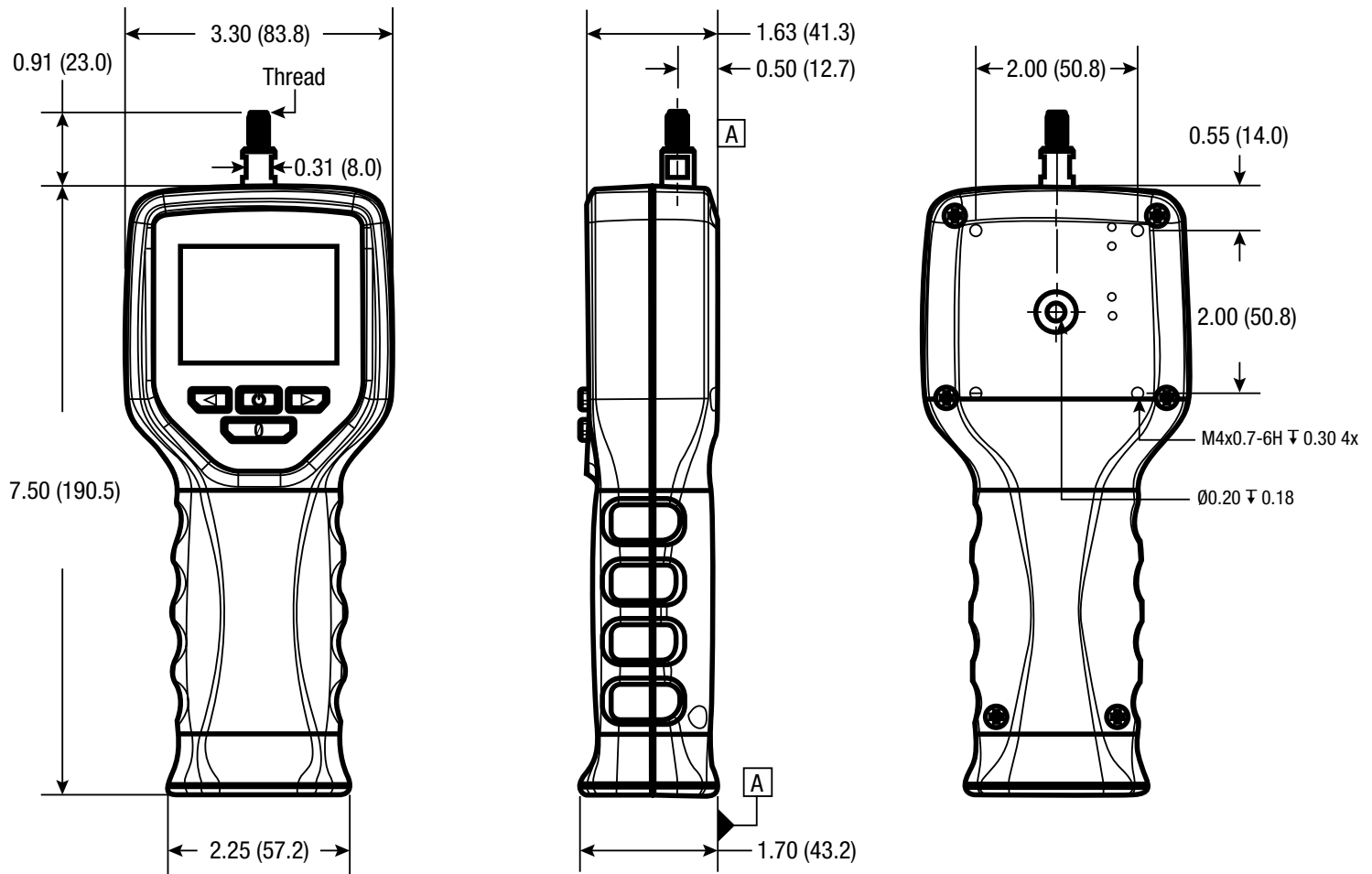

3.0 FORCE GAGE FUNDAMENTALS

3.1 KEYPAD AND NAVIGATION

The DFC keypad is multi-functional. There are four keys. Each is described below.



Shown: Keypad mapping with display in NORMAL format



Shown: Keypad mapping with display in FLIP format

3.1.1 ON/OFF/MENU KEY

This key is used to power the gage on/off. Press to power the gage on. Press and hold for 3 seconds to power the gage off.

This key is also used to access the Setup Menu. When the gage is powered ON, press to access the Setup Menu.

This key is also used to navigate UP when in the Setup Menu. ▲

3.1.2 ZERO KEY

This key is used to zero the displayed values. Press to zero load and if connected to the FMM digital force tester, zero distance.

This key is also used to navigate DOWN when in the Setup Menu. ▼

3.1.3 SOFTKEY 1

This is the left arrow key. It is used to move out of a setup when in the Setup Menu. ◀

This key may also be mapped to a specific function.

The Setup Menu has a Key setup function where you may assign how Softkey 1 performs. For example, you can assign a SAVE function to the key. When pressed, the measured values are "saved" to memory.

3.1.4 SOFTKEY 2

This is the right arrow key. It is used to move in to a setup when in the Setup Menu. ▶

Like the Softkey 1, it also may be mapped to a specific function. For example, you can assign a MODE function to the key. Pressing the key can change the operating modes of the gage. You can switch from Real Time to Peak Tension by pressing Softkey 2.

3.2. DISPLAY LAYOUT

The force gage features a high-resolution OLED color display with adjustable backlight. The backlight may be adjusted from a setting in the Main Menu.

The display layout is optimized for easy viewing. Recognizable symbols are used for immediate interpretation.

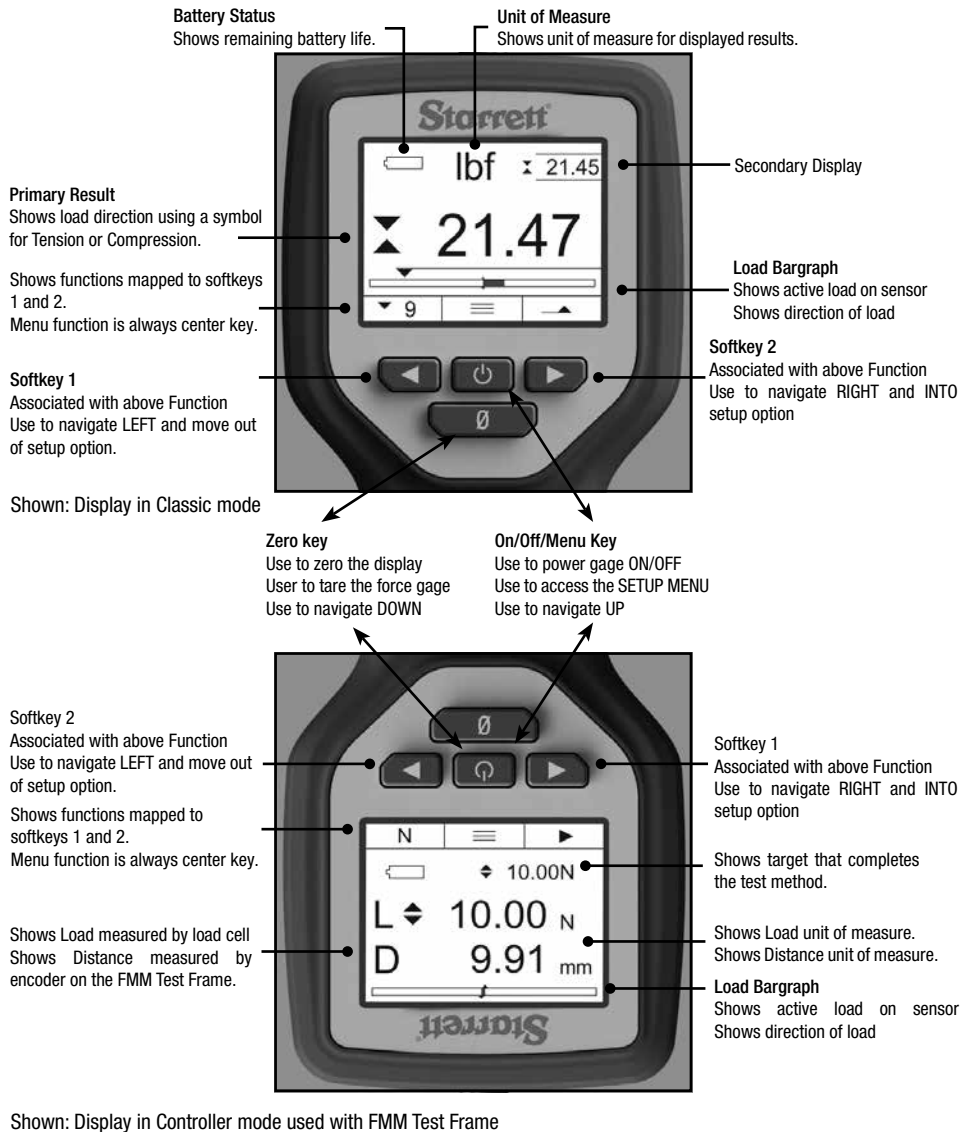

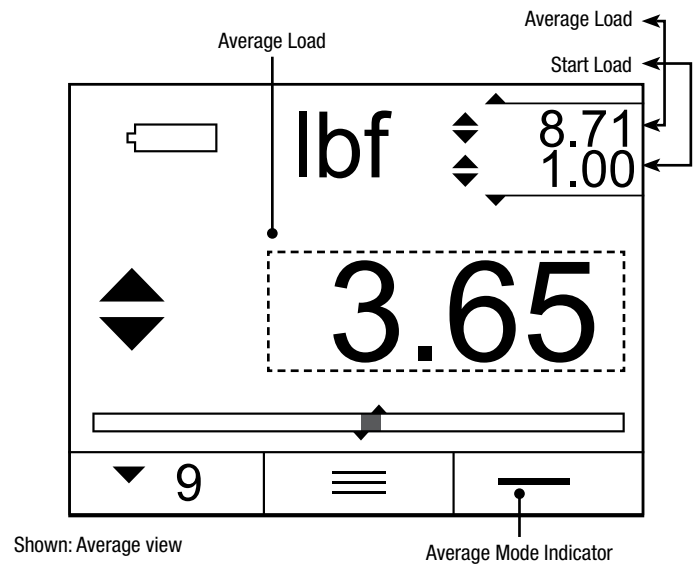
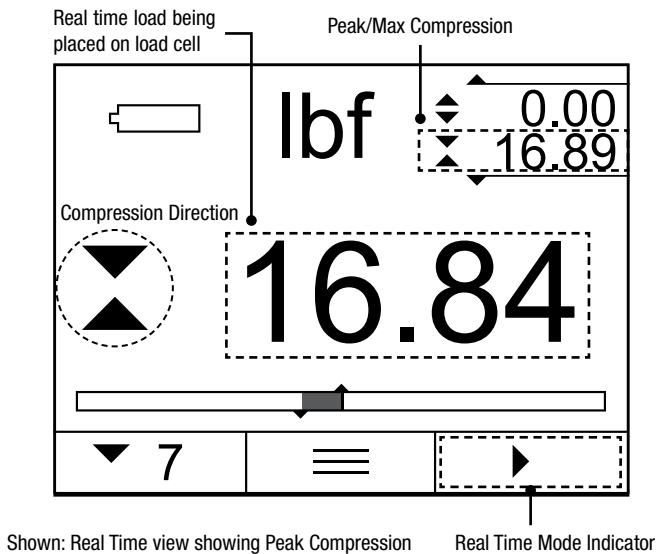
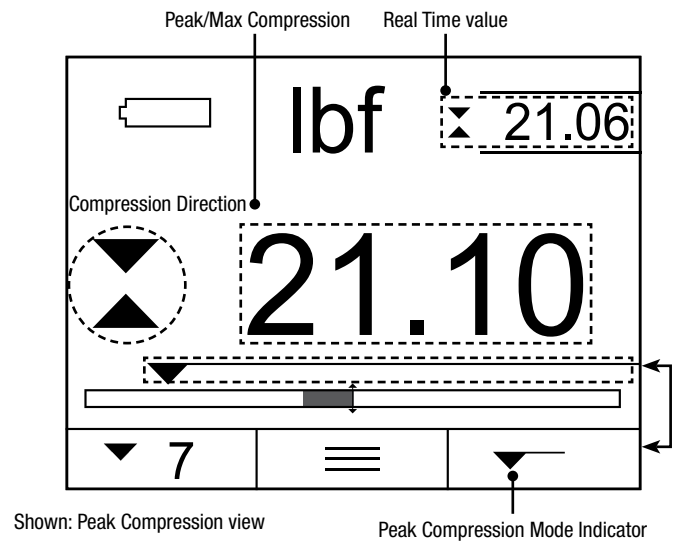
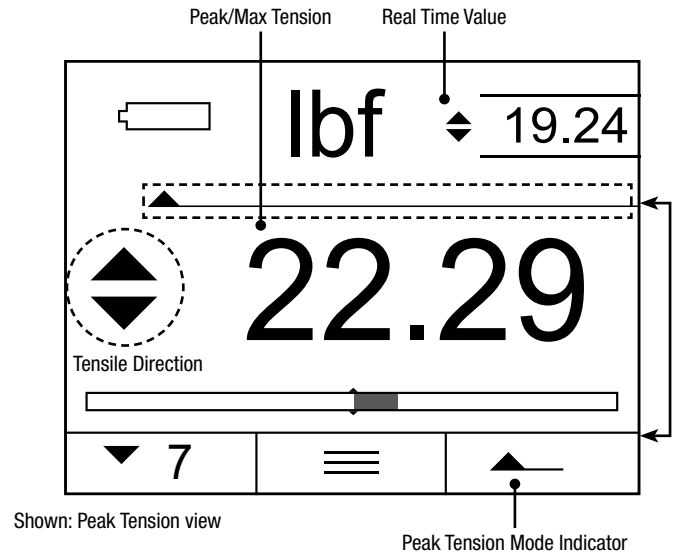
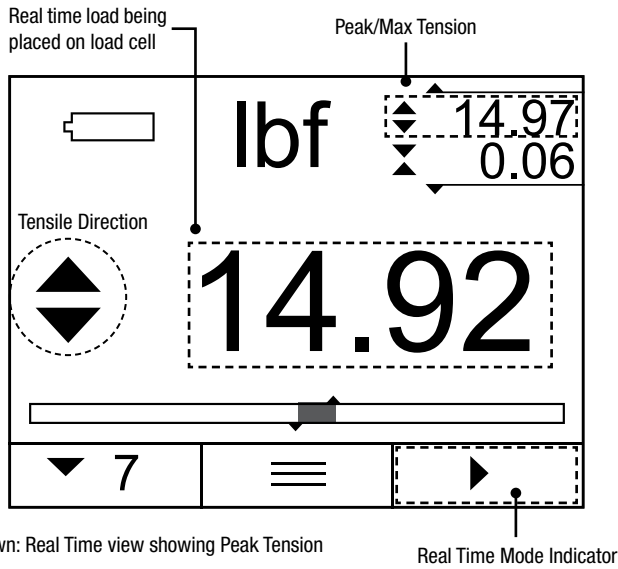

3.2.1 PRIMARY DISPLAY

The center of the display is used to display the primary result(s). This result is displayed in a large format with a resolution of 10,000:1. When tolerance is used, the displayed results will show in RED when the result is "out-of-tolerance". Results "in-tolerance" are displayed in BLACK.

3.2.2 SECONDARY RESULT

The upper right display area shows secondary results. These results vary depending on the force gage mode and the primary result being displayed. For example, if the primary result is a peak measurement, the secondary result displays the real time load being applied.

Display Formats	
Primary Display	Secondary Display
Real Time	Peak Measurement
Peak Tension	Real Time Measurement
Peak Compression	Real Time Measurement
Average	Peak Measurement
Average (Functional Capacity)	Preload to Start Average
Static COF	Peak Measurement
Kinetic COF	Time Duration
Switch	Kinetic COF
	Static COF
	Load at Make/Break
	Peak Measurement

3.2.3 DIRECTION

Symbols are used to indicate the direction of load for the current readings.

3.2.4 TOLERANCE

When a tolerance is setup for your result, results that are "within" the tolerance range are displayed in BLACK. If the results is "outside" the tolerance range, the result is displayed in RED. The gage may also be setup to give a sound if the result is "outside" the tolerance range. The sound is configured in SETUP and may be a "beep", "Chirp" or "Tone".

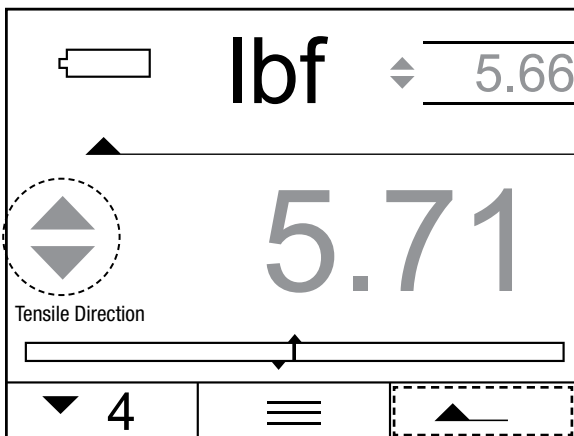

Out-of-Tolerance Result

3.2.5 BARGRAPH

The bargraph shows the measured load as detected by the load cell sensor. The load is displayed from a center line.

Compressive loads fill to the left while tensile loads fill to the right.

Color is used to depict the load status relative to the full scale of the load cell.

The bargraph will display GREEN when the measured load is from 1 to 75% of the full scale capacity.

The bargraph will display YELLOW when the measured load is from 76% to 90%.

The bargraph will display RED when the measured load exceeds 90%.

If the measured load exceeds the full scale capacity of the load cell, the primary display will show a RED "----", indicating an OVERLOAD condition.

The bargraph also uses markers to show maximum values achieved during a test. For example, a marker may depict a peak load measurement.

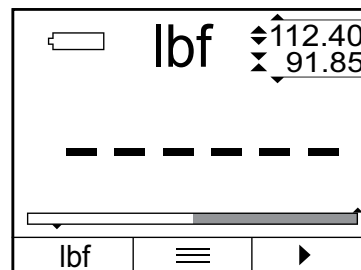
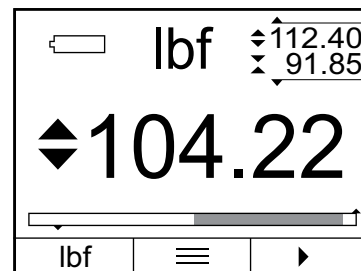
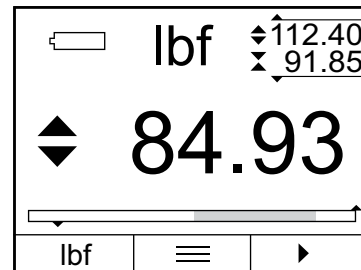
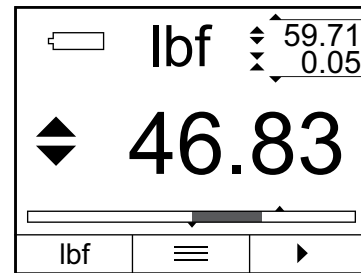

3.2.6 SOFTKEY LABELS

The bottom of the display has three targets that are mapped to the three keys on the keypad.

The right- and left-most keys have dynamic functions that may change based on the test operation being performed. These targets may also be assigned specific functions in the SETUP MENU for KEYS.

The center target is reserved for access to the SETUP MENU.

Softkey Labels		
Symbol	Type	Description
◀	Send	Exports result or memory via RS232 or Bluetooth®
lbf	Units	Changes current unit of measure
▼4	Save	Saves current results to gage memory and shows number of records saved
▼	Mode	Shows current mode and allows modes to be changed
Σ	Stats	Displays statistics for results saved in memory
▶	Start	When TESTS is enabled, used to Start a test method. Works with Stop feature.
■	Stop	When TESTS is enabled, used to Stop a test method. Works with Start feature.
↶	Return 0	When TESTS is enabled, used to return crosshead position on FMM to the zero position

3.2.7 OPERATING MODES

Symbols are used to depict the operating mode of the force gage. The operating mode is a setting in the SETUP MENU.

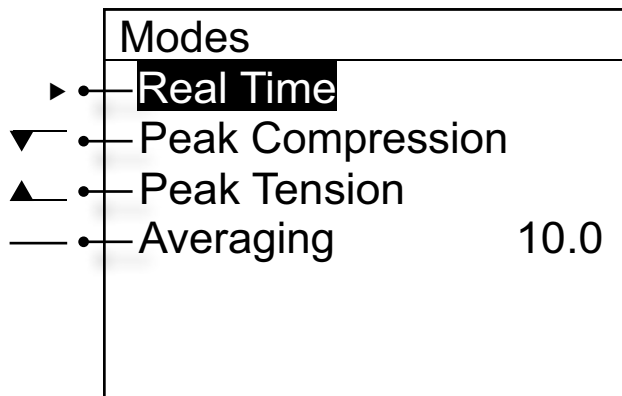

Modes and Symbols

3.2.8 UNITS OF MEASURE

The units of measure is displayed with the associated result. Load results may use ozf, gf, lbf, kgf, or N. Distance results may use in (inch) or mm (millimeter).

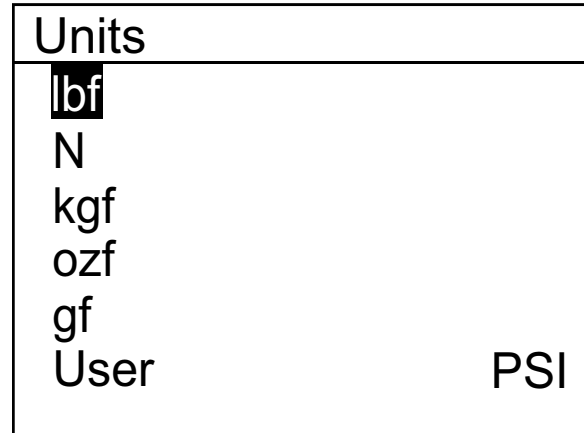

Units of Measure

3.2.9 DISPLAY ORIENTATION (FLIP)

The display orientation may be changed in the SETUP MENU. In applications where the load cell stem needs to point downward, it may be necessary to "flip the orientation" of the display so rather than reading right-side up, the display reads right-side down.



Normal Display View



Flip Display View

3.3 CABLES & I/O

The force gage is supplied with a USB cable.



Force Gage with USB Cable

3.3.1 USB CABLE

The USB cable (p/n L1-USB) is used for charging the force gage. This cable may also be used to connect the force gage to a computer. Using the force gage with a computer, you can upload new software for the force gage, or use it to download data from the gage to the computer. For example, you can download results saved in the force gage memory to Microsoft® Excel®.

NOTE

The USB cable is NOT used for communication to the FMM digital force tester.

3.3.2 RS-232 CABLE

The RS-232 cable (p/n L1-RS232) is a generic communication cable. It may be used with the force gages for communication to a computer.

3.3.3 L1-CONTROL CABLE

The control cable (p/n L1-CONTROL) is used exclusively with the DFC Force Controller when the gage is used to control the FMM Test Frame.

3.4. TEST FRAME OPERATION

The force gage mounts to our test frames with a mounting block (SPK-FG-BLOCK). On the back side of the force gage is an alignment bushing. This bushing fits over the alignment pin on the mounting block to ensure proper gage alignment.

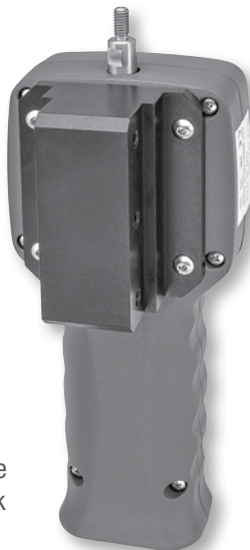

SPK-FG-BLOCK Force Gage Mounting Block

3.4.1. USING FMM TEST FRAMES

Use the mounting block when mounting the force gage to the FMM crosshead. Four M4 screws fasten the force gage to the mounting block. The mounting block is fastened to the crosshead with six screws.



Force Gage Mounted on FMM-110 Test Frame

3.4.2 USING MTL TEST FRAMES

The force gage mounts to the MTL Manual Tester using four M4 screws.



Force Gage Mounted on MTL-110 Test Frame

3.4.3 USING MTH TEST FRAME

The force gage mounts to the MTH Manual Tester using four M4 screws.

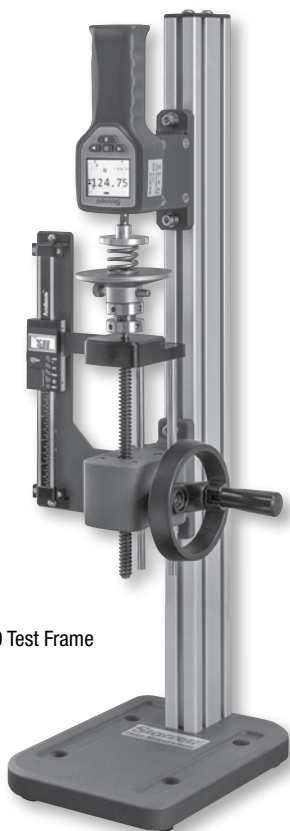

Force Gage Mounted on MTH-550 Test Frame

3.5 LOAD SENSOR MEASUREMENT

The load cell sensor, within the force gage housing, has a measurement accuracy of better than 0.1% full scale and a safe overload rating of 200%. Force gages with a load capacity of 200 lbf (1000N) and below are fitted with an M6 threaded load stem. The 500 lbf (2500N) force gage model is fitted with an M10 threaded load stem.

NOTE

1. Load must always be applied axially. Use care and prevent any side loading on the sensor. Side loading can affect the measurement accuracy and lead to load cell damage.
2. Load cell sensors should NEVER exceed their rated full scale capacity. Overloading the load cell sensor will lead to irreparable damage.
3. Load cell should go through a 10 minute "warm-up" period if the force gage has been turned off for an extended period of time. Turn the force gage on and wait 10 minutes for the load cell electronics to warm-up.



Force Gage Load Cell Stem Thread

3.6. USING ACCESSORIES

The DFC Force Gage can use standard gage accessories for common types of testing. Or, you can equip the DFC Force Gage with a clevis adapter. With a clevis adapter, a large assortment of testing fixtures are available from Starrett including platens, vise-action grips, wedge-action grips, peel grips, pneumatic grips, roller grips and more. Starrett can supply hundreds of different style grips for virtually any force measurement application. And Starrett can design, engineer, and manufacture custom grips and test fixtures to your exact requirements.

A complete list of accessories can be found in Section 6.

3.6.1 STANDARD GAGE ACCESSORIES

The force gage is supplied with a variety of standard accessories suitable for the full scale measuring capacity of the instrument. All gages are supplied with these threaded accessories. Accessories are supplied as "Kits" or you may purchase any accessory individually.

Part No.	Accessory Kits
SPK-FG-A	Aluminium, 5 lbf load capacity, M6 threads; Includes Hook, Flat, Point, Notch, Chisel and 6-inch Rod
SPK-FG-S	Stainless, 100 lbf load capacity, M6 threads; Includes Hook, Flat, Point, Notch, Chisel and 6-inch Rod
SPK-FG-M	Stainless, 200 lbf load capacity, M6 threads; Includes Hook, Flat, Point, Notch, Chisel and 6-inch Rod
SPK-FG-L	Stainless, 500 lbf load capacity, M10 threads; Includes Hook, Flat, Point, Notch, Chisel and 6-inch Rod

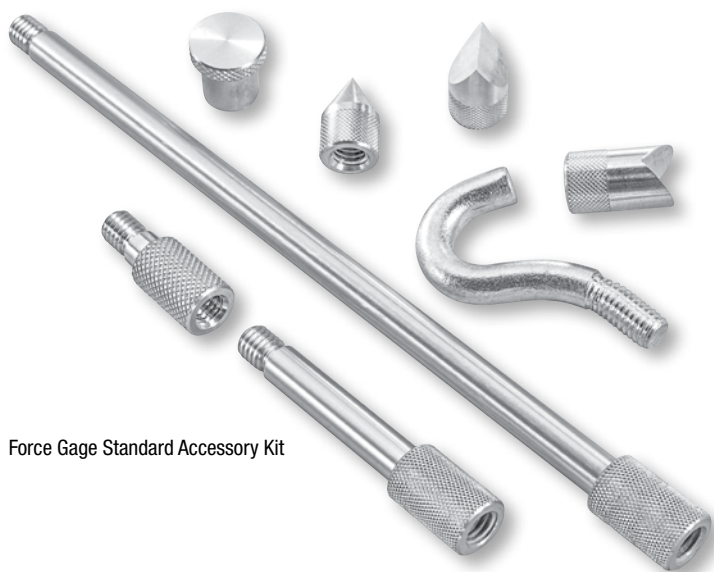

Force Gage Standard Accessory Kit

3.6.2 CLEVIS ACCESSORIES

The DFC Force Gage can be fitted with an optional clevis adapter. This adapter lets you affix any 15.9mm diameter clevis-style test fixture to your force gage.

Clevis fixtures are ideal for applications where you need to quickly change-out test fixtures. The clevis adapter, screws on to the DFC Load Cell Stem. Two locking rings and a grip pin are used to secure the test fixture during your test.

Part No.	Accessory Kits
SPK-CLEVIS-A	Aluminium, 5 lbf load capacity, M6 thread; Includes clevis, locking rings (2), grip pin and spanner wrench
SPK-CLEVIS-S	Stainless, 200 lbf load capacity, M6 thread; Includes clevis, locking rings (2), grip pin and spanner wrench
SPK-CLEVIS-L	Stainless, 500 lbf load capacity, M10 thread; Includes clevis, locking rings (2), grip pin and spanner wrench

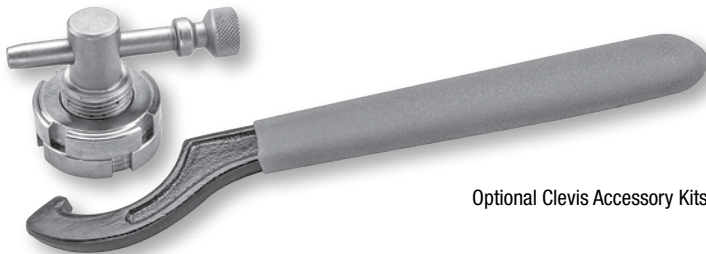

Optional Clevis Accessory Kits

4.0 FORCE GAGE OPERATION

4.1 POWER ON/OFF

Turn the force gage ON by pressing the Power key.

Turn the force gage OFF by pressing and holding the Power key down for 3 seconds.



4.1.1 AUTOMATIC SHUTDOWN

The force gage may be setup to automatically turn OFF after a period of time when no load has been applied or when no keypress has taken place.

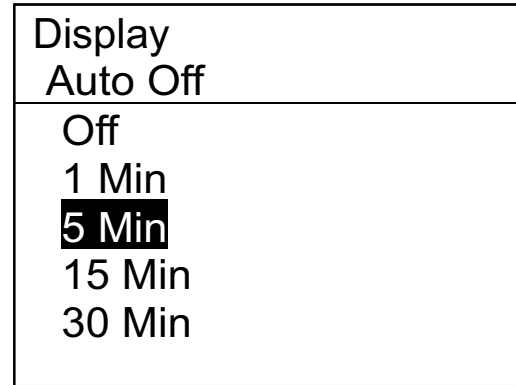

4.1.2 CHARGING BATTERY

Auto Off Setup Option (See Setup for more information)

Charge the battery using the USB Cable that was supplied with the force gage. Connect the USB cable to the force gage and then to the power source.

Charging through source power @ 100-240V is considerably faster than charging through a personal computer's USB.

NOTE

1. When the force gage is connected to the FMM Digital Force Tester using the RS-232 cable, the force gage is continually being charged while the FMM digital force tester is ON.
2. The force gage may be used while it is being charged.
3. The force gage display will remain ON during charging. You cannot turn the force gage to OFF during a charge.

4.2 GAGE DISPLAY FORMATS

This section will show common display formats and their attributes.

4.2.1 REAL TIME DISPLAY

When the force gage is in REAL TIME MODE, the force gage will display the following:

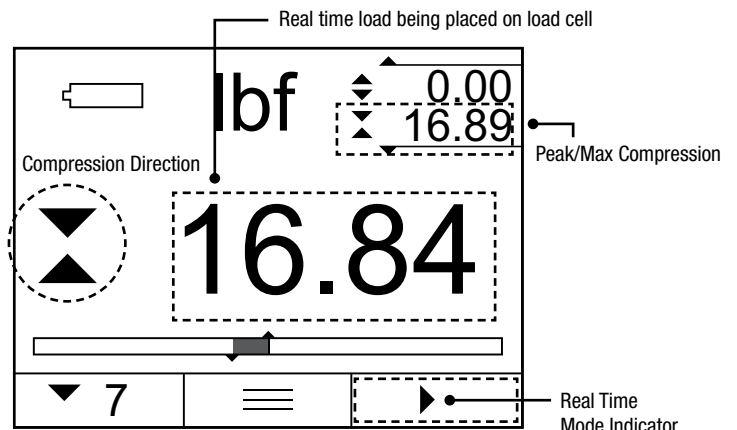

Shown: Real Time view showing Peak Compression

4.2.2 PEAK TENSION DISPLAY

When the force gage is in PEAK TENSION MODE, the force gage will display the following:

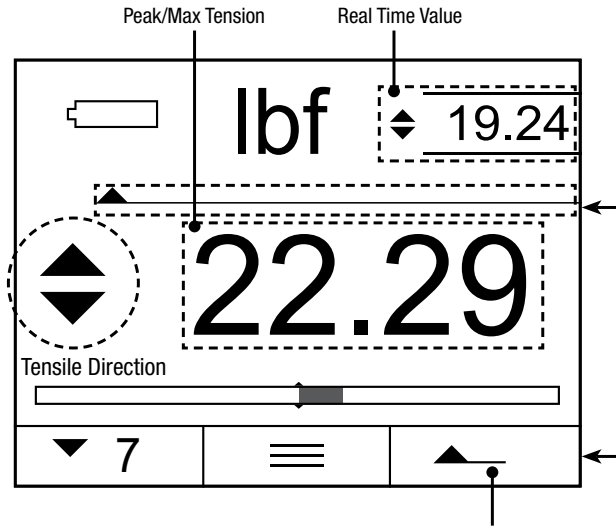

Shown: Peak Tension View

4.2.4 TOLERANCE DISPLAY

When tolerance is used for a measurement, the force gage will display the following:

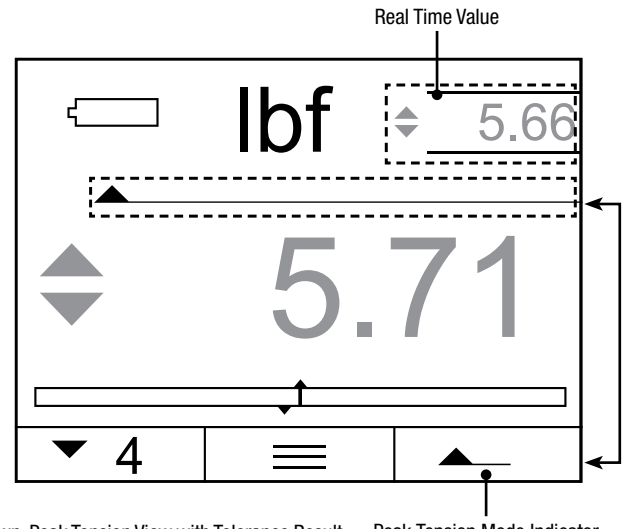

Shown: Peak Tension View with Tolerance Result

4.2.3 PEAK COMPRESSION DISPLAY

When the force gage is in PEAK COMPRESSION MODE, the force gage will display the following:

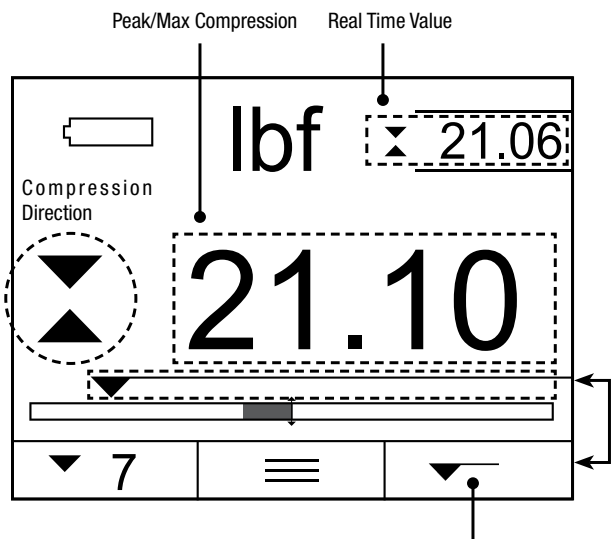

Shown: Peak Compression View

4.2.5 STATISTICS DISPLAY

When statistics are used on saved results, the force gage will display the following:

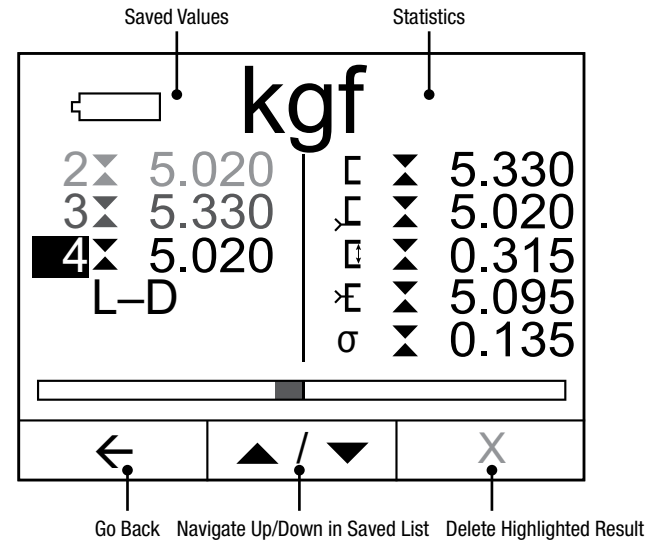

Statistics Display

NOTE

When using statistics, all results in the memory must have the same sign: tension or compression for valid statistics.

4.2.6 AVERAGE DISPLAY

When averaging is used, the force gage will display the following:

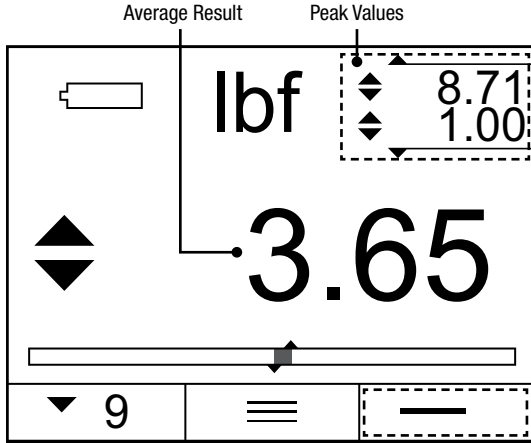

Load Average Display

4.2.7 COEFFICIENT OF FRICTION (COF) DISPLAY

When the force gage is used to measure coefficient of friction, the force gage will display the following:

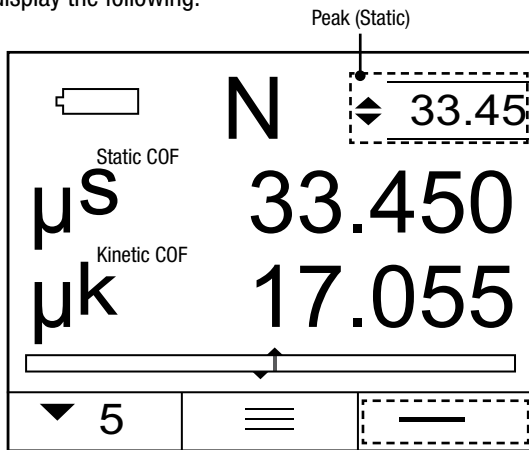

COF Display

4.2.8 MEMORY DISPLAY

When results are saved to memory, the force gage will display the following for the saved results:

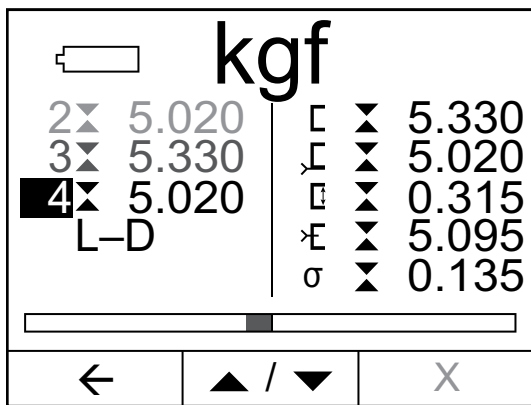

Results Saved to Memory

4.2.9 OVERLOAD CONDITION DISPLAY

When the load applied to the force gage's load cell exceeds the full scale capacity, an overload condition occurs and the force gage will display the following:

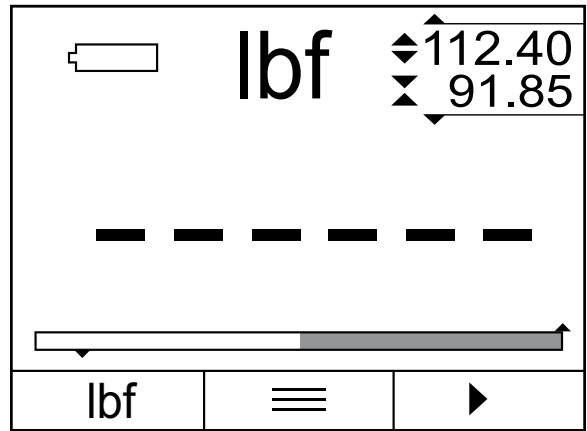

Load Overload Display

NOTE

Immediate action to remove the overload should be taken to avoid permanent damage to the load cell sensor.

4.2.10 ABOUT DISPLAY

The About view is accessed through the main setup menu. Select the About menu option and the DFC Series will display the following:

- DFC Model Number
- Serial Number
- Full Scale Capacity
- Last Calibration Date
- Overload History

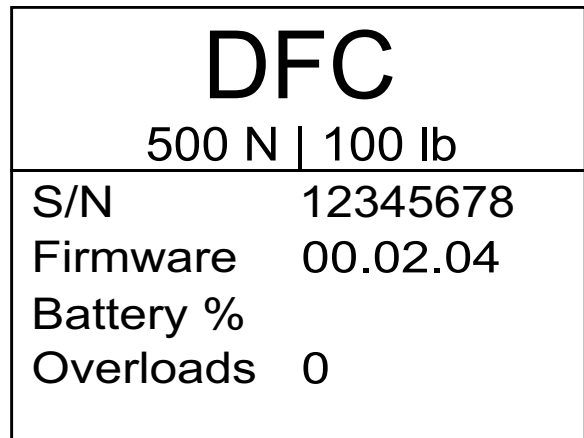

About Display

4.3 CONTROLLER DISPLAY FORMATS

This section will show the display formats and their attributes when the DFC is used as a Controller with the FMM Digital Test Frame. As a Controller, the DFC Series will display both load and distance information and results. The gage will serve as the universal interface for the "system" and will be used to setup the force gage and the tester.

The DFC Force Gage will display load information, as measured by the load cell.

The DFC Force Gage will display distance information, as measured by the FMM Digital Force Tester.

DFC with FMM Test Frame in Controller Mode

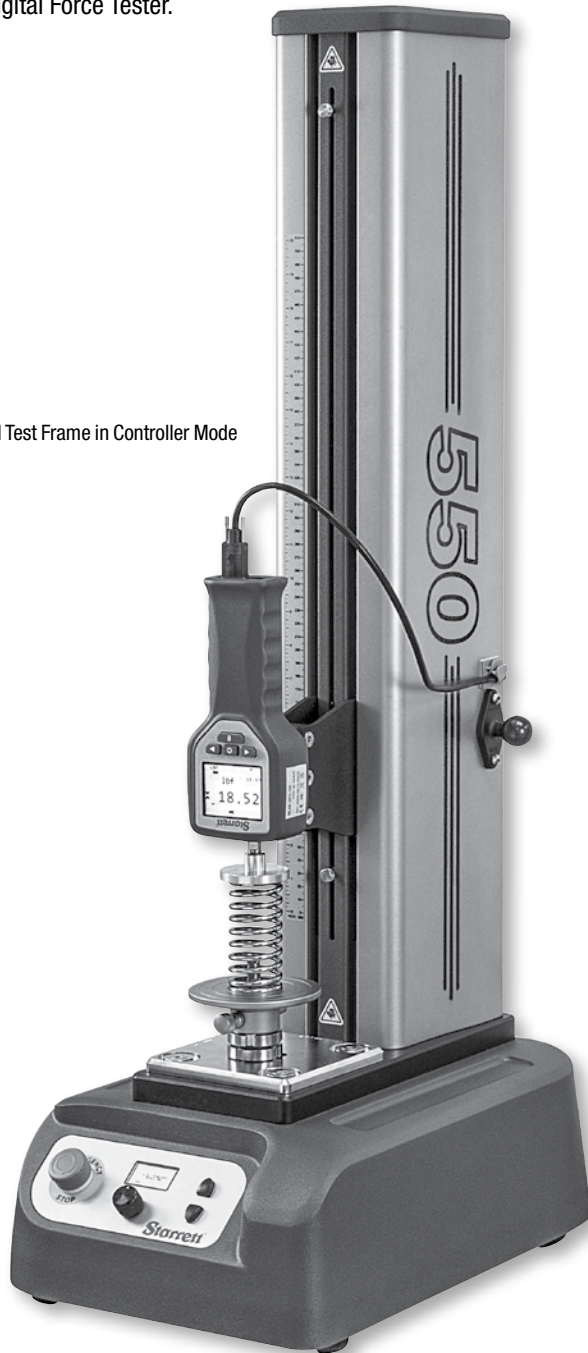

4.3.1 LOAD LIMIT DISPLAY

When performing a Load Limit test, the force gage will display the following:

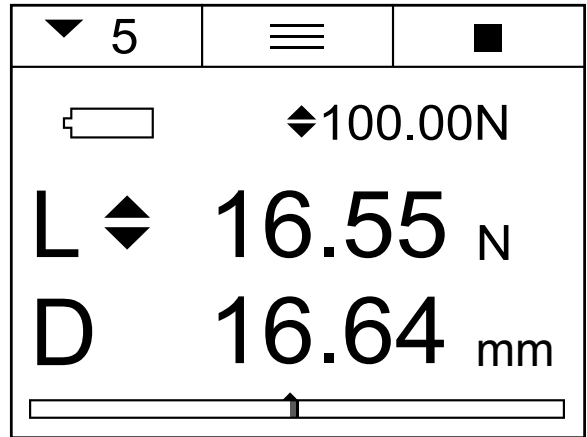

4.3.2 DISTANCE LIMIT TEST DISPLAY

When performing a Distance Limit test, the force gage will display the following:

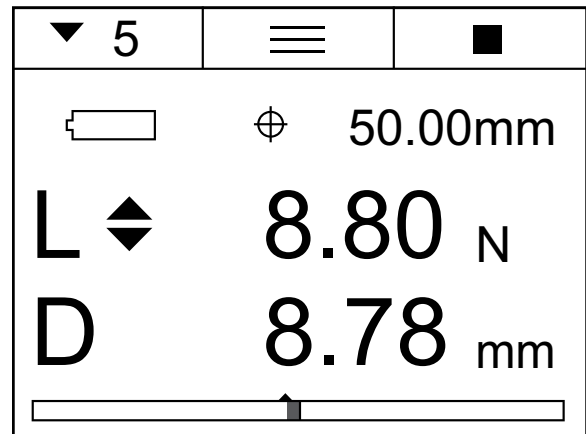

4.3.3 BREAK LIMIT TEST DISPLAY

When performing a Break Limit test, the force gage will display the following:

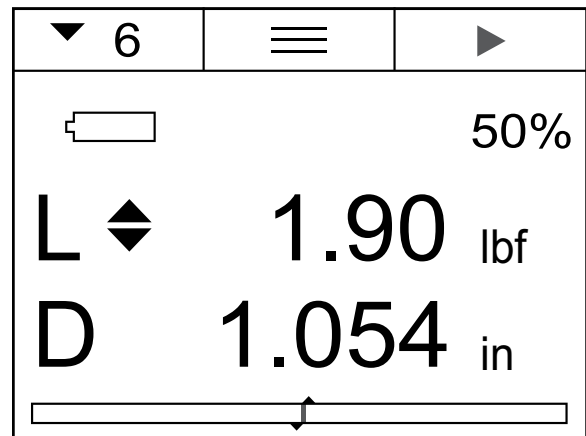

4.4 SAVING RESULTS

The DFC feature an internal memory for saving results for the purpose of calculating and displaying statistics. You may save up to 99 individual results in memory.

Results saved to memory MUST be of the same type. You cannot have mixed type results. For example, you cannot save tension results with COF results. Results MUST be of the same type.

Results obtained using the TESTS feature are saved in pairs. For each test, there is a Load and Distance result (L-D). You cannot save results from different types of tests. For example, you cannot save results from a Load Limit test with results from a Break Limit test. Each load-distance pair of results must have come from the same test type: Load, Distance or Break.

Result Type	Memory Type
Modes	
Real Time	Real Time
Tension Peak	Tension Peak
Compression Peak	Compression Peak
Average	Average
Static COF	Static COF
Kinetic COF	Kinetic COF
Tests	
Load Limit Test	
Distance @ Limit	Distance @ Limit
Load Limit	Load Limit
Distance Limit Test	
Load @ Limit	Load @ Limit
Distance Limit	Distance Limit
Break Limit Test	
Load Max (Peak Load)	Load Max (Peak Load)
Distance @ Load Max	Distance @ Load Max

Management of the DFC memory is important to ensure correct statistical analysis. Always clear old results that are from a different test method.

NOTE

Results saved for statistics must be of the same test method for statistics to be correctly calculated.

To Save results to memory, a Softkey must be setup with the SAVE function. See the Setup section for more information.

Once a result is displayed by the DFC Series, pressing the SAVE softkey will save the displayed result to memory.

Results may be saved with or without units.

4.5 EXPORTING RESULTS

The DFC can export results to an external device, such as a computer with WinWedge software. Use the Send function to export a result to WinWedge on a computer connected to the DFC Force Gage.

4.6 CLEARING RESULTS FROM MEMORY

Results may be cleared from memory using the Memory setup or using the Statistics view.

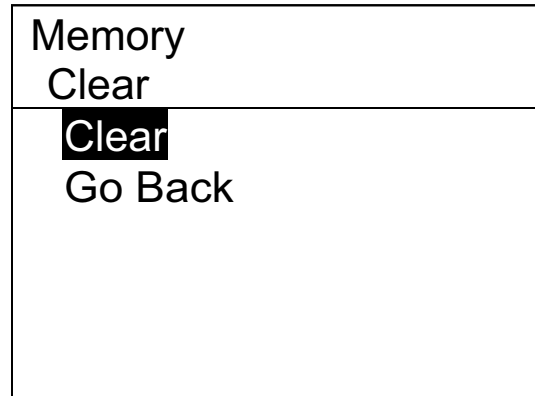

To clear results from memory using the Memory setup, do the following:

- Press ▲ Select MENU
- Press ▼ Select MEMORY
- Press ► Select CLEAR
- Press ▼ Select CLEAR
- Press ◀ Move out of MEMORY
- Press ◀ Move out of Setup

To clear results from memory at the Statistics view, select the memory record and select "X".

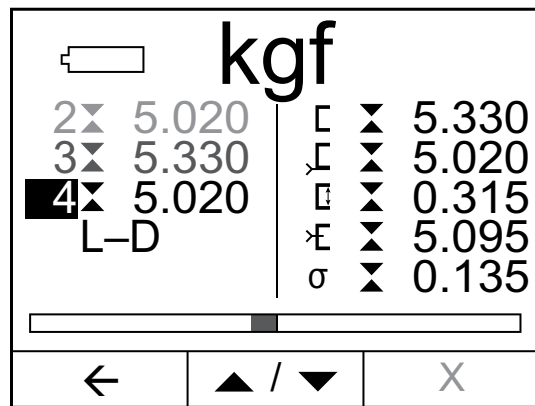

4.7 VIEWING MEMORY

You may view results in memory using either a STATS softkey or by going through the main menu and selecting the Memory and Display options.

- Press ▲ Select MENU
- Press ► Select MEMORY
- Press ► Select DISPLAY

The saved results in memory are displayed in the left column of the Statistics view.

Results are saved to memory by pressing the SAVE softkey. Each saved results is one record in memory. You may have up to 99 records.

If you are using the TESTS feature, results are saved in pairs. There is a result for LOAD (L) and a result for DISTANCE (D). When TEST results are saved, there are two results for each record in memory. You may have up to 99 records, or 198 results.

NOTE

When using the TESTS feature, results are saved in pairs (Load and Distance, or L-D). Each pair of results occupies one record in memory, so you may have up to 99 pairs of results or 99 single results.

4.7.1 VIEWING SINGLE RESULTS

View individual results saved to memory as follows:

- Press ▲ Select MENU
- Press ► Select MEMORY
- Press ► Select DISPLAY
- Press ▲ to navigate UP your results
- Press ▼ to navigate DOWN your results
- Press X to DELETE a result

4.7.2 VIEWING RESULTS FOR TESTS (PAIRS L-D)

Load and Distance are saved when using TESTS. You can view each result type (Load or Distance) by pressing the L-D function.

- Press ▲ Select MENU
- Press ► Select MEMORY
- Press ► Select DISPLAY
- Press ▼ to L-D symbol
- Press L-D softkey to view LOAD results
- Press L-D softkey again to view DISTANCE results
- Press X to DELETE the highlighted result

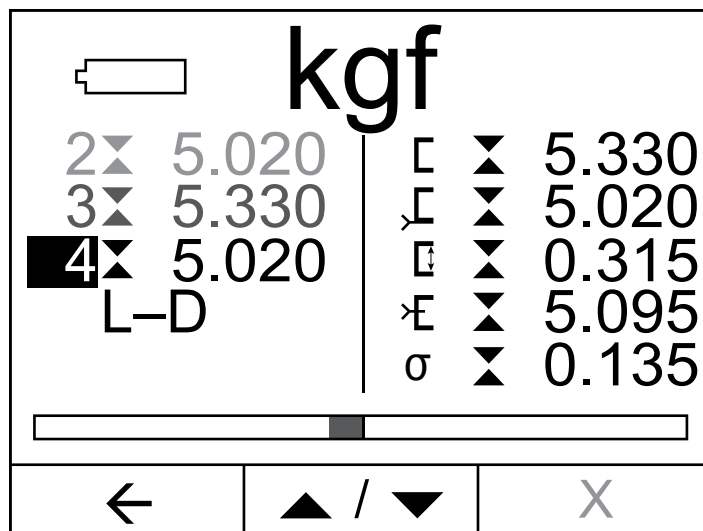

Memory View- Single Results

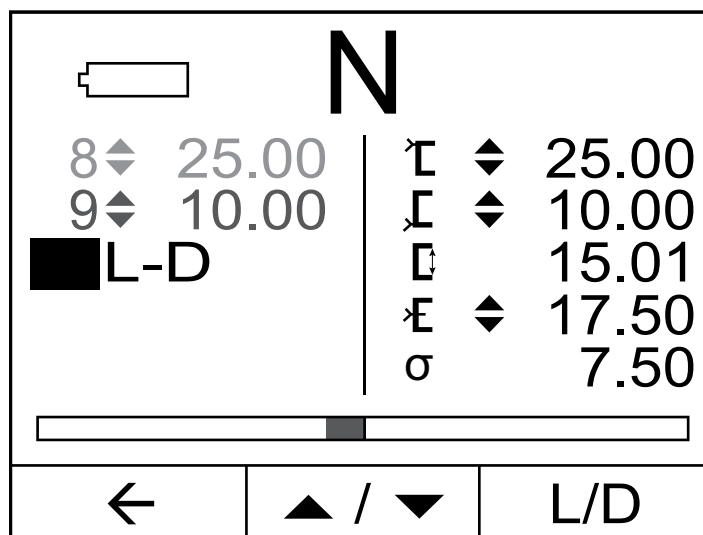

Memory View- Using TESTS showing pairs L-D

5.0 FORCE GAGE SETUP MENU

The SETUP MENU for the force gage is depicted below. Shown are the options available for each feature within your DFC Force Gage.

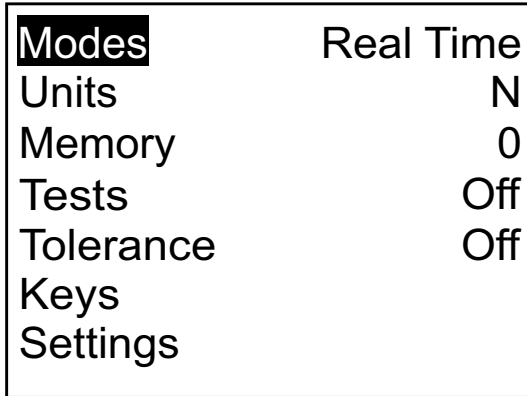

Main Menu

Modes	Units	Memory	Tests	Tolerance	Keys	Settings
Real Time	ozf	Display	Enable	Enable	Enable	Comms
Peak Tension	lbf	Clear	Load Limit	Limit 1	Softkey 1	Data Channel
Peak Compression	gf	Export	Type	Limit 2	Send	RS-232
Averaging	kgf		Target	Sound	Units	Xmit Comp -
Time Avg	N		Speed		Save	Xmit Units
COF	User		Distance Limit		Mode	Xmit TOL
			Type		Stats	Display
			Target		Start/Stop	Auto Off
			Speed		Return 0	Backlight
			Break Limit		Softkey 2	Flip
			Type		Send	Radix
			Minimum Break		Units	Filter
			% Drop		Save	About
			Auto 0		Mode	Password
			Auto Return		Stats	Language
			Auto Save		Start/Stop	English
					Return 0	Deutsch
						Español
						Português
						Français
						Italiano
						Chinese
						Russian
						Polski
						Czech

5.1 MODES

This section will describe the various operating modes for the force gage.

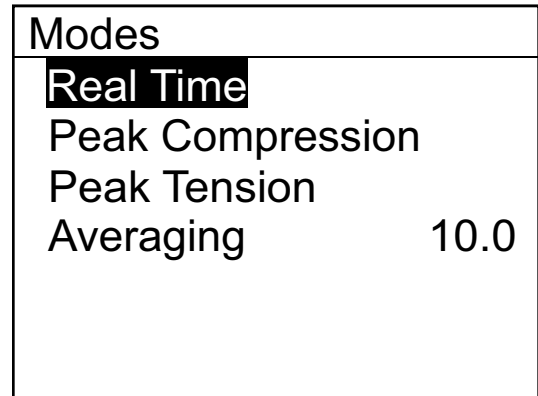

Mode Setup Menu

- Press ▲ Select MENU
- Press ► Select MODE
- Press ► Select the Mode needed
- Press ◀ Move out of MODE
- Press ◀ Move out of Setup

NOTE

MODE may be assigned to Softkey 1 or Softkey 2. This will allow you to switch between modes using a Softkey press.

5.1.1 REAL TIME

The REAL TIME MODE displays the load that is currently being applied to the load cell.

The primary display shows the currently applied load.

The secondary display shows the PEAK TENSION or PEAK COMPRESSION values achieved during the real time measurement.

The REAL TIME MODE is depicted by this symbol:

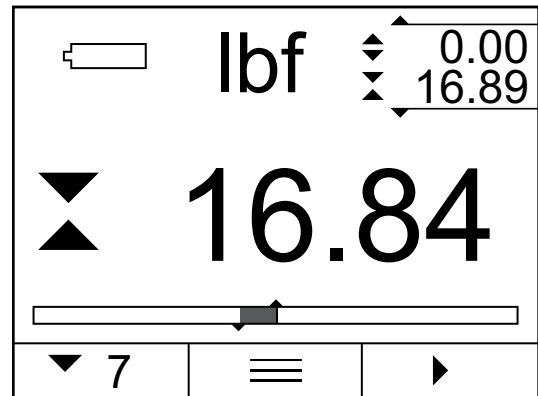

Real Time Mode Display

5.1.2 PEAK COMPRESSION

The PEAK COMPRESSION MODE displays the maximum load achieved during a compression (Push) direction.

The primary display shows the results for the maximum achieved load in the compression direction, i.e. the peak compression result.

The secondary display shows the Real Time result or what is currently being applied to the load cell.

The PEAK COMPRESSION MODE is depicted by this symbol:

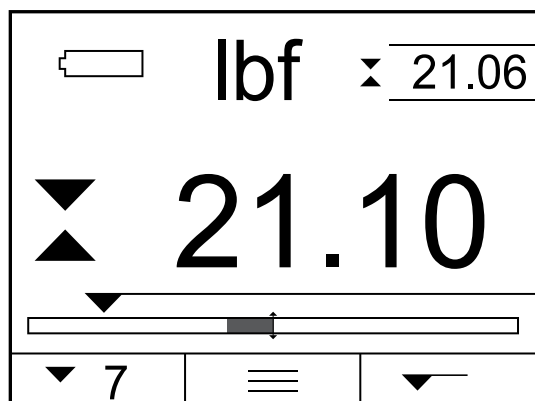

Peak Compression Display

5.1.3 PEAK TENSION

The PEAK TENSION MODE displays the maximum load achieved during a tensile (Pull) direction.

The primary display shows the results for the maximum achieved load in the tensile direction, i.e. the peak tension result.

The secondary display shows the Real Time result or what is currently being applied to the load cell.

The PEAK TENSION MODE is depicted by this symbol:

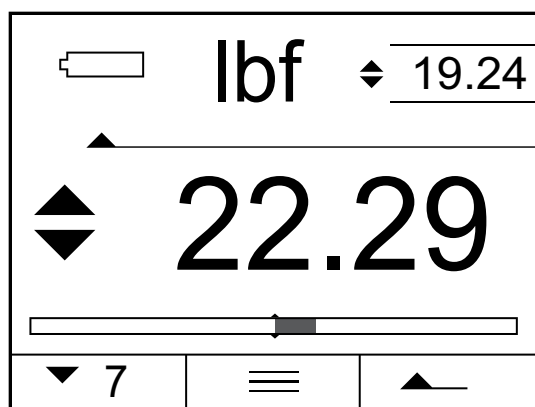

Peak Tension Display

5.1.4 AVERAGING

The DFC lets you calculate an average load based on a Start Load and using a Duration (time-based average). The averaging function is also used to measure and display the kinetic COF when the gage is used for coefficient of friction testing.

NOTE

You must configure the parameters for measuring and displaying averaging results by FIRST using the AVE SETUP menu.

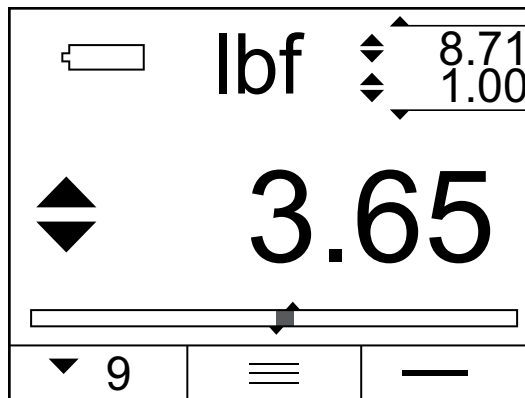

Averaging Result Display

5.2 AVERAGE SETUP

The AVERAGE setup is used to configure the force gage for average measurements when time is involved.

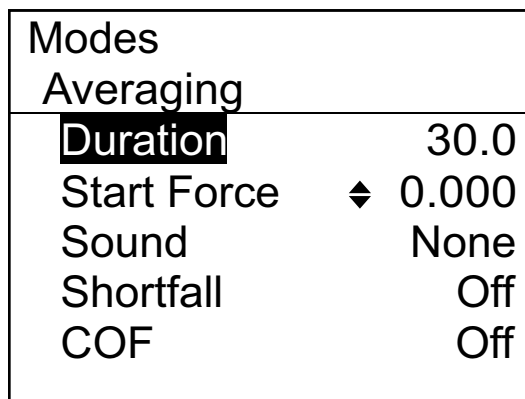

Average Mode Setup Menu

- Press ▲ Select MENU
- Press ► Select AVE MODE
- Press ► Select ENABLE
- Press ► Select ON
- Press ◀ Move out of Enable
- Press ▼ Move down to DURATION

5.2.1. DURATION

The DURATION is the amount of time that the test will require and represents the duration of time for the average result. For example, if the Duration = 30 seconds, the load average will be taken from the start of the test to the end of the test, which required 90 seconds to complete.

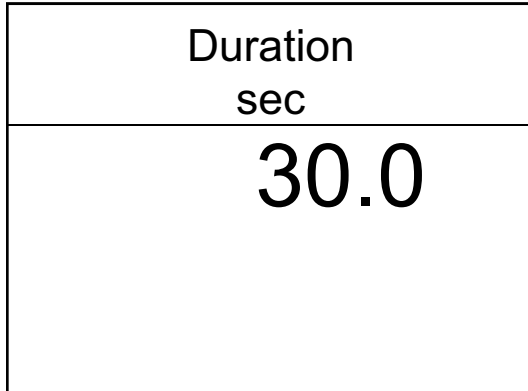

Duration Setup

- Press ▼ Move down to duration
- Press ► Select the DURATION needed
- Press ◀ Move out of DURATION

5.2.2. START FORCE

The START FORCE is a pre-condition load. It represents "when" to begin calculating the average load. If the material exhibits a noisy load at start, often seen in peel testing, you can set a START FORCE. You must reach this load first before the load average begins being calculated.



Start Force Setup

- Press ▼ Move down to START FORCE
- Press ► Select the START FORCE needed
- Press ▲ Select for a Tensile Start Force or
- Press ▼ Select for a Compression Start Force
- Press ◀ Move out of START FORCE

NOTE
The START FORCE is sign-dependent. Press the ON/OFF/UP key to increment to a greater TENSION value. Press the Zero/Down key to increment to a greater COMPRESSION value.

5.2.3. SOUND

A SOUND can be configured to provide the user with an audible signal of when the START occurs and if a SHORTFALL was encountered. The SOUND default is NONE. The SOUND may be a "beep", "chirp" or "tone".

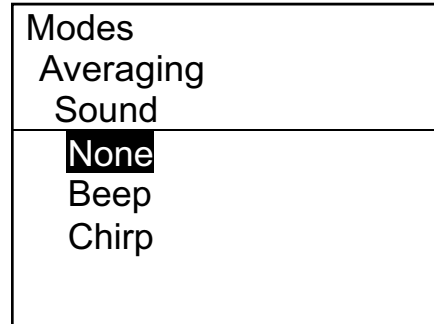

Sounds Setup Menu

- Press ▼ Move down to SOUND
- Press ► Select the SOUND needed
- Press ◀ Move out of SOUND

NOTE
The "Beep" option is a short instantaneous sound. The "Chirp" option is a longer sound that the "Beep" type.

5.2.4. SHORTFALL

A SHORTFALL represents the load band where the load average is being calculated. See next page for an illustration.

For example, you may have a SHORTFALL = 15lbf. When 15lbf is measured, the load averaging will start for the DURATION you have specified.

If the measured load falls BELOW the SHORTFALL, the test is invalid. Averaging will stop. For the test to be valid, the measured load must achieve the SHORTFALL to start the test and the applied load must remain ABOVE the SHORTFALL for the full DURATION specified.

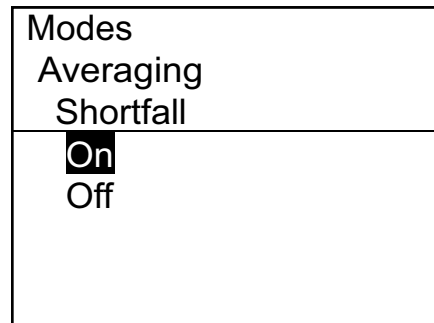

Average Shortfall Setup

- Press ▼ Move down to SHORTFALL
- Press ► Select SHORTFALL ON or OFF if needed
- Press ◀ Move out of SHORTFALL

NOTE
1. Shortfall should be used when you are using a Start Force and a Duration and where you want to measure the average within a specified range based on load and time.
2. Shortfall is not required for averaging unless you are using a load range and time duration.

5.2.5. COEFFICIENT OF FRICTION

The force gage may be used to measure kinetic and static coefficient of friction.

Modes	
Averaging	
COF	
Enabled	Off
Initial Delay	0.0
Sled Mass	0.200

Coefficient of Friction Setup Menu

- Press ▲ Move down to COF
- Press ► Select Enable ON
- Press ► Select Initial Delay
- Enter Delay value in Seconds, Press ▲▼
- Press ► Select Sled Mass
- Enter Sled Mass value, Press ▲▼
- Press ◀ Move out of COF

5.2.5.1. KINETIC COF

The kinetic COF result is the average load measured. COF is a unit-less value so no units of measure are applied. The kinetic COF is the measured average load divided by the mass used. An initial delay may be configured so that the average is measured starting at the end of the initial delay to the end of the test.

5.2.5.2. STATIC COF

The static COF results is the maximum load measured. COF is unit-less so no units of measure are applied. The static COF is the maximum load divided by the mass used.

N		33.45
μs	33.450	
μk	17.055	
▼ 5	≡	—

COF Display

SHORTFALL EXAMPLE

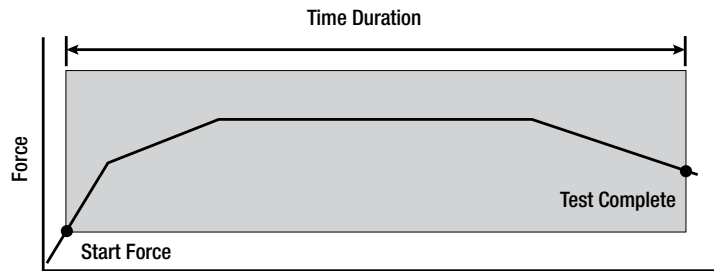

"Passed" Test using Shortfall

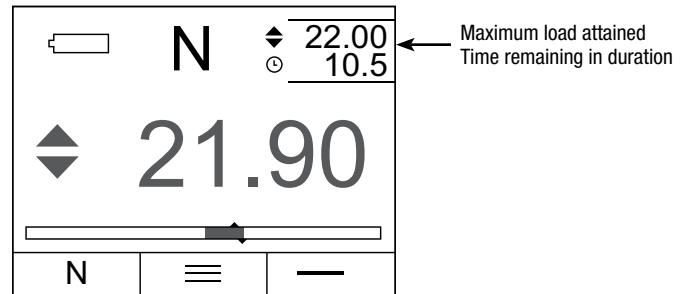

Average view during a test with shortfall enabled

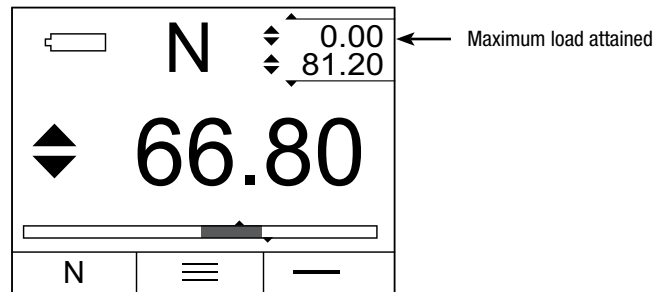

Average view at test completion

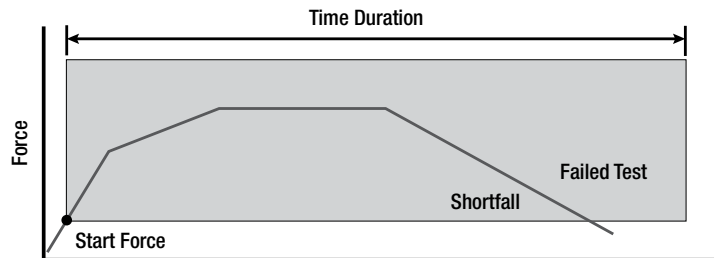
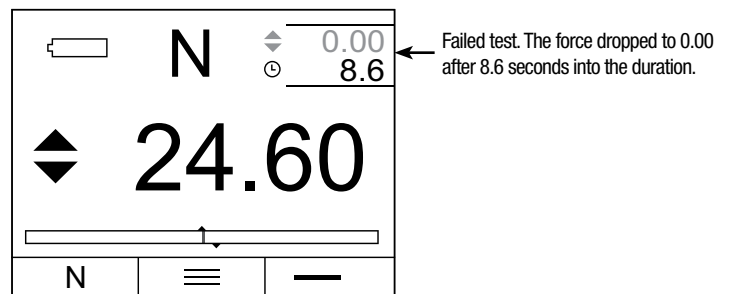

"Failed" Test using Shortfall

5.2.5.3. INITIAL DELAY

You may assign an initial delay in seconds. The initial delay is used to correct determine the Kinetic COF. The Kinetic COF is the average load after the Static COF. Static COF should not be included in the Kinetic COF calculation. The initial delay is a time duration, after when the peak load occurred and when the sled is in continuous motion.

Initial Delay sec
10.0

Initial Delay Setup

5.3.5.4. SLED MASS

ASTM D1894, used to determine slip resistance on plastic films, recommends a 200g ±2g mass. The mass may have either a felt or rubber surface depending on the sample under test.

Sled Mass kgf
0.200

5.3 UNITS OF MEASURE

Set the units of measure as follows:

Units	
lbf	
N	
kgf	
ozf	
gf	
User	PSI

Units of Measure Setup Menu

- Press ▲ Select MENU
- Press ► Select UNITS
- Press ► Select the Unit needed
- Press ◀ Move out of Units
- Press ◀ Move out of Setup

The USER type units of measure lets you create a custom unit or a unit that is not typically used in force measurement, but which may be measured using the force gage. An example, could be Torque where the measured force is applied clockwise on to an armature.

Units	
User	
User Label	Flb
User Scaler	+0.3372
in/mm	in

USR Units Setup

5.3.1 USER LABEL

You may label your custom units using 3 characters. Characters may be any number or letter. The default label is USR.

- Press **▶** to navigate to each character space
- Press **▲▼** to enter a numeric or alpha character

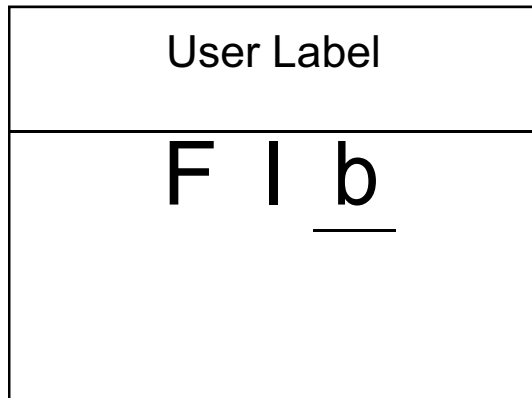

User Label Setup

5.3.2 USER SCALAR

The User Scalar is a conversion value to use for a custom unit of measure. For example, assume you want to determine the torque when applying a force onto a 18-inch armature using the DFC Series force gage.

You create a user label called FLB (foot pounds or ft-lb). Since the armature is 18-inches in length, 18 inches = 1.5 feet.

When using the USR units, load is always based on Newtons. Therefore, convert Newtons to lbf using 0.2248. 1 Newton = 0.2248 lbf.

Determine the Scalar value using the following:

$$(0.2248) \times (1.5) = 0.3372$$

0.3372 is the scalar value to use.

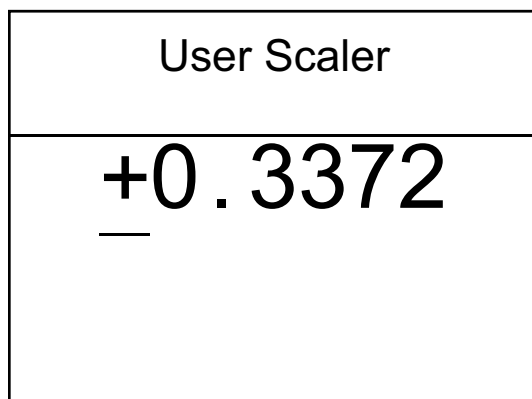

User Scalar Setup

5.3.3 IN/MM

Use in when you want your User result to be in imperial units. And use mm when you want your User result to be in SI units, based on metric values.

NOTE

UNITS may be assigned to Softkey 1 or Softkey 2. When assigned, pressing the Softkey will allow the user to change units of measure each time the key is pressed.

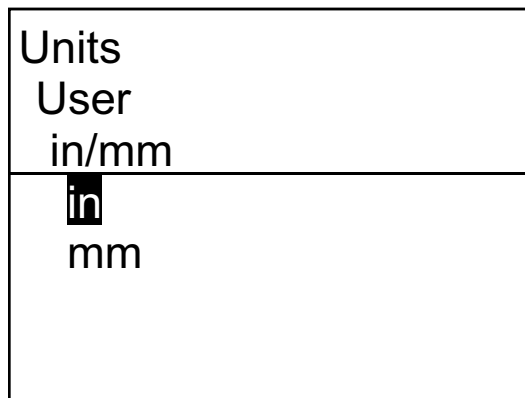

User Units Type

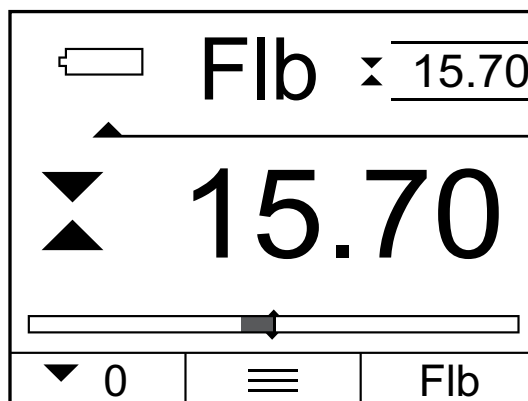

Result with Custom Units

When load was applied to the armature to the specified distance, the measured load was 46.56 lbf.

Converting 46.56 lbf of force to torque we use the conversion factor of 0.3372.

$$(46.56) \times (0.3372) = 15.70 \text{ lb-in}$$

5.4. MEMORY SETUP

The DFC has memory for saving up to 99 results. Results may be saved manually, by pressing a softkey or automatically at the completion of a test.

Results in memory can be displayed and used for statistics or exported to an external device.

NOTE
Because results in memory are used for statistical calculations, all results in memory must be of the same type. For example, saved results should be all tension results in order for statistics to be calculated correctly.

- Press ▲ Select MENU
- Press ▼ Select MEMORY
- Press ► Select DISPLAY to view memory and Statistics
- Press ► Select CLEAR to erase ALL results from Memory
- Press ► Select EXPORT results to an external Device
- Press ◀ Move out of MEMORY

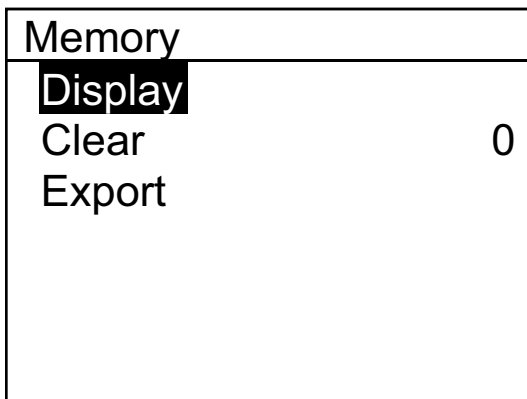
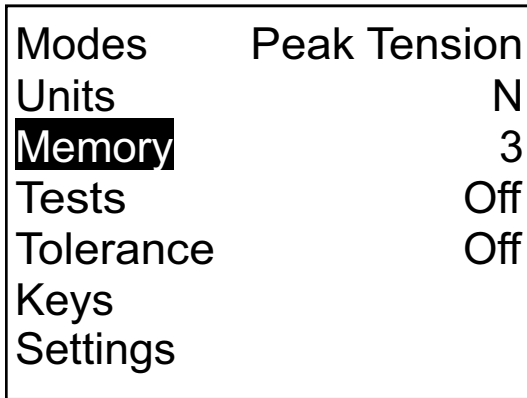

5.4.1. DISPLAY MEMORY

You can view the results in memory using the Memory menu or by mapping a softkey to STATS.

From the Memory setup, select Display to view the results in memory. From the main menu:

The DFC will display the saved results in memory in the left column while displaying the calculated statistics in the right column.

Press the center power key and zero key to navigate up/down to view your results.

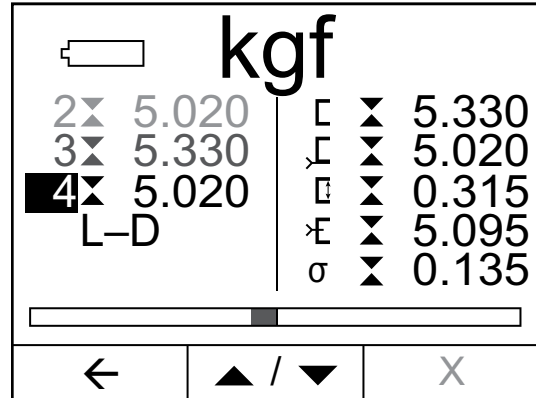

Display Memory View

Press the X softkey to delete the highlighted result.

Press the Back softkey to move out of the Display Memory view.

NOTE
Results saved from TESTS are saved as pairs. TEST results are saved with both the Load and Distance result (L-D). TEST result pairs are a single record within the memory registry, so you can save up to 99 pairs of L-D results using the TESTS feature.

5.4.2. CLEAR MEMORY

Results in memory may be cleared individually or collectively. To clear an individual result from memory, go to the STATS view. Select the results you want to clear. Select the "X" (delete) key.

To clear all results from memory, go to the Memory setup and select CLEAR. This will erase all results for the gage's memory.

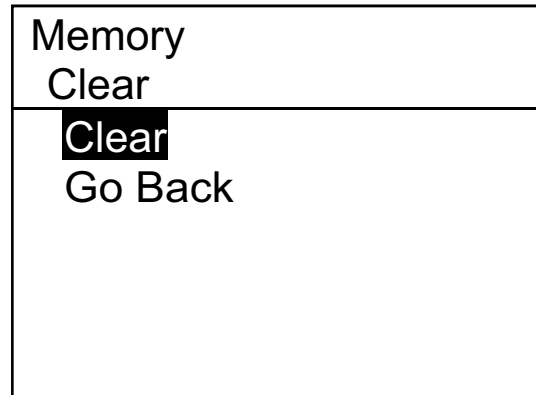

Clear Memory Setup

5.4.3. EXPORT MEMORY

Use the SAVE feature to save results to memory. Results saved to memory MUST be of the same type based on test mode or test type. For example, the DFC Series will not allow you to save a tension result with a COF result.

If you attempt to save a different result type with an existing result, the gage will display a message requiring you to delete the results currently in memory.

5.4.3.1 EXPORT SAVED RESULTS

Results may be exported to a externally connected device, such as a personal computer using the Send feature. You must map one of your softkeys to SEND. Press the SEND key to transmit the result via RS232 to the connected device.

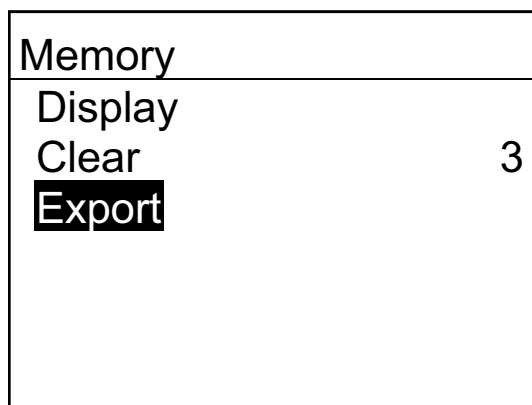

Export Memory Setup

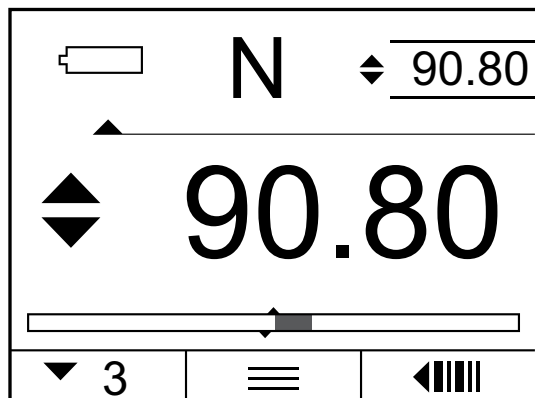

SEND Softkey

5.5. TESTS (FMM FORCE TESTER)

The DFC Force Gage can be used as the universal interface for systems comprised of a DFC Force Gage with an FMM Digital Test Frame. The force gage is used to setup the test method to be used. The force gage is also used to setup the FMM Digital Test Frame's test velocity and any associated distance setpoints for a test. There is no need to setup of the force gage and then setup the digital force tester. All test setup parameters are done through the DFC Force Gage.

The DFC Force Gage will also display load and distance information for your test.

Modes	Peak Tension
Units	N
Memory	3
Tests	Off
Tolerance	Off
Keys	
Settings	

Tests Setup Menu

5.5.1. TEST MODE

When the TEST MODE = OFF, the DFC Force Gage operates as a classic digital force gage. If operating with the FMM Digital Test Frame, you will configure the force gage and the force tester independently.

Selecting a TEST MODE configures the DFC Force Gage as a "controller". As a controller, the DFC Force Gage is used to setup three common test methods. The gage serves as the universal interface to the FMM Digital Force Tester while also serving as the load measuring and display instrument.

When the DFC Force Gage is a controller, it performs the following functions:

Modes	Peak Tension
Units	N
Memory	3
Tests	Off
Tolerance	Off
Keys	
Settings	

Enable TESTS Feature Setup Menu

- Used to setup test methods
- Use to measure loads
- Used to setup the FMM Test Frame
- Used to display load and distance results

As a controller, the DFC works with the FMM Digital Force Tester to perform the following test methods:

- Load Limit
- Distance Limit
- Break Limit

5.5.2. LOAD LIMIT TEST METHOD

When the TEST MODE = LOAD LIMIT, the DFC Force Gage is used to perform a Load Limit test. All setup parameters for the test are performed through the force gage. Test speed is configured through the DFC Force Gage.

The Load Limit test establishes a load setpoint that concludes the test. When the test reaches this load setpoint, the test is complete. The FMM Series crosshead will stop. The force gage will display the Distance at the Load Limit.

Tests	
Test Mode	
Off	
Load	
Distance	
Break	

Load Limit Test Selection

5.5.2.1 LIMIT TYPE

The Limit TYPE is used to specify whether the test is a tensile (pull) or compressive (push) test. If the TYPE=TENSION, the crosshead will move in the tensile direction and move upward. If the TYPE=COMPRESSION, the crosshead will move in the compression direction and move downward.

Tests	
Test Mode	
Load	
Type	Tension
Target	◆ 10.00
Speed	10.000

Tests	
Test Mode	
Load	
Type	
Compression	
Tension	

Load Limit Type Selection

5.5.2.2 LIMIT TARGET

The Limit TARGET is the load value when you want the test to finish. Enter a TARGET VALUE. When the test starts, the crosshead will continue to move until the TARGET VALUE is achieved, as measured by the DFC Force Gage. Once the load limit test has finished, the DFC Force Gage will display the LOAD TARGET and the DISTANCE AT THE LOAD TARGET.

NOTE

At the completion of your Load Limit test, the DFC Series force gage will display the Load Target value and the Distance at the Load Target value, i.e., the distance the crosshead traveled to reach the Load Target.

Tests	
Test Mode	
Load	
Type	Tension
Target	◆ 10.00
Speed	10.000

Target	
lbf	
◆ 10.00	

Setup Load Limit Target

5.5.2.3 TEST SPEED

The TEST SPEED is the crosshead velocity you want the test method to operate at.

Tests	
Test Mode	
Load	
Type	Tension
Target	◆ 50.00
Speed	6.000

Setup Test Speed to Target

5.5.3. DISTANCE LIMIT TEST METHOD

When the TEST MODE = DISTANCE LIMIT, the DFC Force Gage is used to perform a Distance Limit test. All setup parameters for the test are performed through the force gage. Test speed is configured through the DFC Force Gage.

The Distance Limit test establishes a distance setpoint that concludes the test. When the crosshead reaches the Distance Limit, the force gage measures the Load at the Distance Limit.

Tests	
Test Mode	
Off	
Load	
Distance	
Break	

Setup Distance Limit Type

5.5.3.1 LIMIT TYPE

The Limit TYPE is used to specify whether the test is a tensile (pull) or compressive (push) test. If the TYPE=TENSION, the crosshead will move in the tensile direction and move upward. If the TYPE=COMPRESSION, the crosshead will move in the compression direction and move downward.

Tests	
Test Mode	
Distance	
Type	Tension
Target	1.220
Speed	0.039

5.5.3.2 LIMIT TARGET

The Limit TARGET is the distance value when you want the test to finish. Enter a TARGET VALUE. When the test starts, the crosshead will continue to move until the TARGET VALUE is achieved. Distance is read by the encoder inside the FMM Series digital force tester. The distance is the measured travel by the crosshead from the Zero position. The encoder transmits the distance values continuously to the DFC Force Gage and the gage displays the moving distance until the TARGET VALUE is achieved. Once the TARGET VALUE is achieved, the test will finish.

Target
in
2.000

Distance Limit Target Setup

NOTE

At the completion of your Distance Limit test, the DFC Force Gage will display the Distance Target value and the Load at the Distance Target value.

5.5.3.3 TEST SPEED

The TEST SPEED is the crosshead velocity you want the test method to operate at.

Tests	
Test Mode	
Distance	
Type	Tension
Target	2.000
Speed	6.000

Speed to Distance Limit Setup

5.5.4. BREAK LIMIT TEST METHOD

When the TEST MODE = BREAK LIMIT, the DFC Force Gage is used to measure the maximum load and the associated distance at the maximum load based on a break criterion that is used to conclude the test. All setup parameters for the tester are performed through the force gage. Test speed is configured through the DFC Force Gage.

The Break Limit test establishes the maximum or peak load that occurred prior to the break condition that ended the test. When the break condition occurs, the crosshead will stop. The DFC Force Gage will display the maximum load and the distance at the maximum load.

Tests	
Test Mode	
Off	
Load	
Distance	
Break	

Break Limit Setup Menu

5.5.4.1 LIMIT TYPE

The Limit TYPE is used to specify whether the test is a tensile (pull) or compressive (push) test. If the TYPE=TENSION, the crosshead will move in the tensile direction and move upward. If the TYPE=COMPRESSION, the crosshead will move in the compression direction and move downward.

Tests	
Test Mode	
Break	
Type	Tension
Min Break	↕ 20.00
% Drop	50
Speed	51.00

Break Limit Type Setup

5.5.4.2 MINIMUM BREAK

The MINIMUM BREAK is a pre-condition. The MINIMUM BREAK is a load value. The MINIMUM BREAK is the load that must FIRST be achieved BEFORE the DFC Force Gage begins to look for a drop in load. This drop in load is the assumption that the material has fractured or ruptured.

The MINIMUM BREAK is used since some materials being tested exhibit excessive load noise when load is first applied. This noise results in substantial peaks and valleys of the load channel.

Min Break	
lbf	
↕	5.00

Minimum Break Setup

5.5.4.3 % DROP

The % DROP is the percentage drop in load from a previous measured maximum load. The DFC will continuously measure the load during the test. Once the MINIMUM BREAK is achieved, the DFC Series will continuously measure the load, looking for the maximum measured load and then looking for when the measured load has dropped by a percentage as defined by the % DROP value.

For example, if the MINIMUM BREAK is 25lbf, during the test, the DFC will begin looking for a percentage decrease in the measured load AFTER 25lbf. If the maximum measured load is 100lbf, and the measured load has decreased by a 10% DROP to 90lbf, the DFC Force Gage concludes the test.

% Drop
50

% Drop Setup

NOTE

At the conclusion of a Break Limit test, the DFC will display the Maximum (Peak) Load and the Distance at the Peak Load.

5.5.4.4 TEST SPEED

The TEST SPEED is the crosshead velocity you want the test method to operate at.

Tests	
Test Mode	
Break	
Type	Tension
Min Break	↕ 5.00
% Drop	50
Speed	2.500

Test Speed Setup

5.5.5 USING AUTO 0

When AUTO 0 is enabled, when you start your test, the Load and Distance values are automatically zeroed. You do not have to press the Zero key on the force gage.

If AUTO 0 = Off, you are required to manually zero by pressing the gage softkey.

Tests	
Test Mode	Load
Auto 0	On
Return to 0	On
Auto Save	Off

Auto Zero Setup

5.5.6 USING RETURN TO 0

When RETURN to 0 is ON, at the completion of the test method, the crosshead will return to its zero position.

If RETURN to 0 is OFF, at the completion of the test method, the crosshead will stop. You may return the crosshead to its original zero position manually.

Tests	
Test Mode	Load
Auto 0	On
Return to 0	On
Auto Save	Off

Tests	
Return to 0	
On	
Off	

Auto Return Setup

5.5.7 USING AUTO SAVE

The AUTO SAVE function automatically saves your test results when your test method completes. At the completion of your test method, the Load and Distance results from your test are saved to the gage memory.

If AUTO SAVE is OFF, at the completion of the test method, you may save your results to memory manually by pressing the SAVE softkey.

Tests	
Test Mode	Load
Auto 0	On
Return to 0	On
Auto Save	Off

Tests	
Auto Save	
On	
Off	

Auto Save Setup

5.5.8 TEST MODE ERROR MESSAGES

The DFC will display error messages when using the TESTS feature and when unexpected events occur. Listed in the table are the codes that are displayed, their possible cause, and suggested actions to take to correct the issue.

Error Code	Possible Cause	Correction
E1_WATCHDOG	A problem has occurred within the FMM test frame.	Contact your Service Representative.
E2_ESTOP	The active test was stopped because the Emergency Stop Switch was engaged.	Dis-engage the Emergency Stop Switch. If the Emergency Stop Switch is not engaged, check the electrical connection to the switch.
E3_JOG	The active test was stopped because a jog key on the FMM test frame was pressed.	During an active test, do not press either the UP or DOWN jog key unless you intend to stop the test. Check the manual operation of the UP and DOWN jog key to ensure they are working properly. Contact your Service Representative if either jog key appears
E4_SENSOROL	The active test was stopped because the DFC encountered an overload.	Make sure that your test is operating within the specified load capacity of the DFC being used for the test.
E7_FRAMEOL	The active test was stopped because the load limits specified for the test on the DFC are beyond the load limit specifications for the FMM test frame being used. This may occur if a DFC-500 (500lbf) force gage is configured with a test with a load limit greater than the FMM-110 (110lbf) can support.	No test may operated beyond the maximum load specifications of the FMM test frame being used. The test frame is always the highest load limit that may be achieved for any test setup. Lower the load limit to a value equal to or below the FMM test frame capacity. Check cable connections between the DFC and the FMM tester.
E8_NOHEARTBEAT	Communication between the DFC and FMM test frame has been interrupted.	Ensure cable is correct type (L1-Control). Ensure cable connection is tight and secure.
E9_TESTERROR	The test setup has incomplete setup information and cannot operate.	Check the test setup. Ensure that all setup fields are complete with correct and allowed values.
E10_FOLLOWERROR	During a test, the crosshead is unable to maintain velocity.	Contact you Service Representative to review your FMM test frame's tuning parameters. The test velocity is too high for the measured load. Reduce the test speed setting for your test.
E11_TESTABORT	During an active test, the test was stopped.	Restart the test.
E12_MOTIONERROR	The crosshead attempted to move at a velocity that is too fast for the test setup.	Decrease the maximum allowed speed for your test setups.

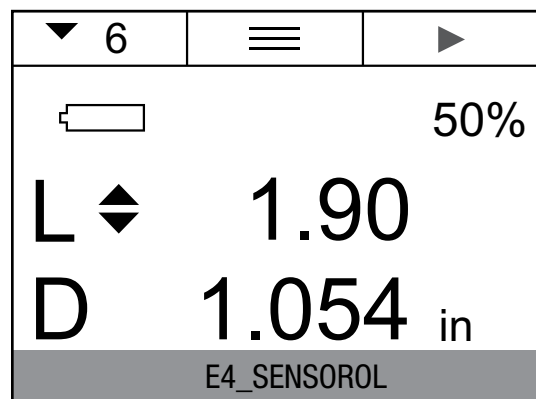
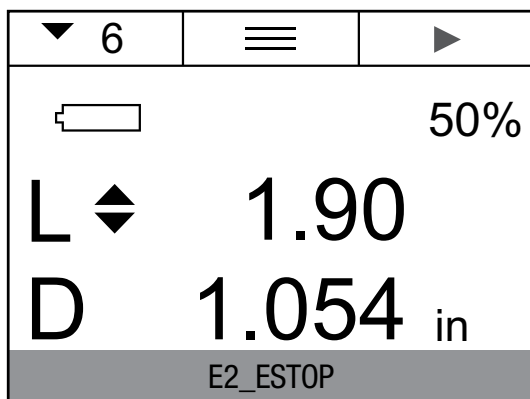
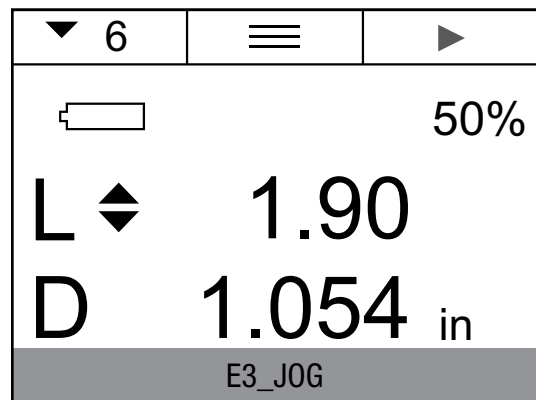
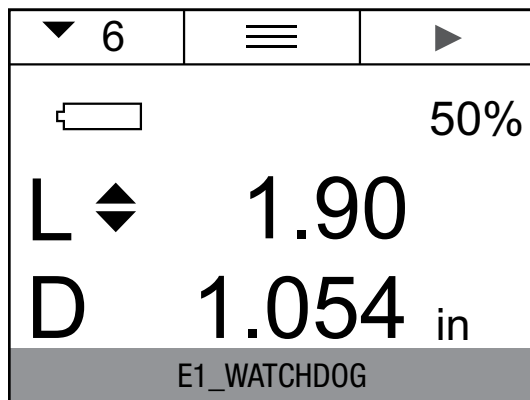

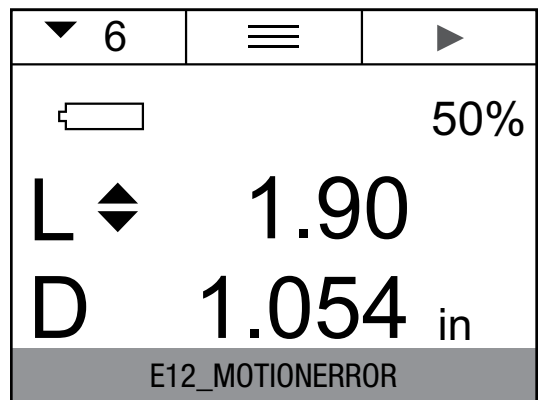
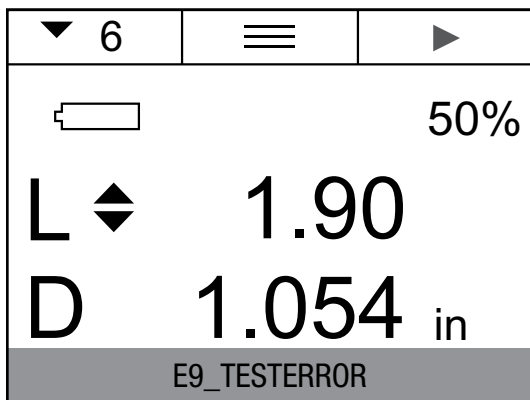
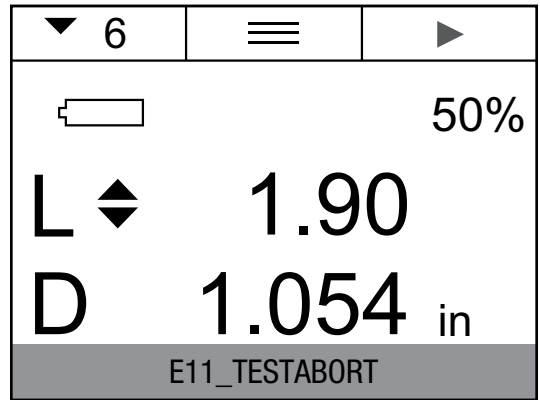
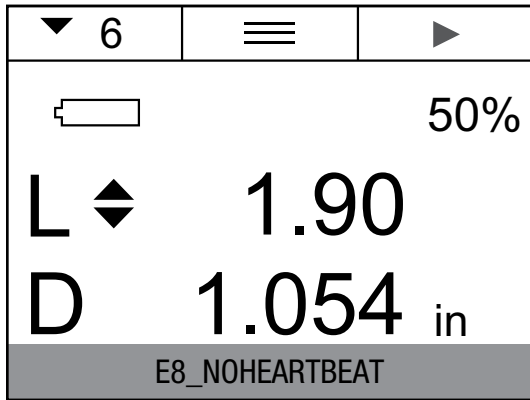
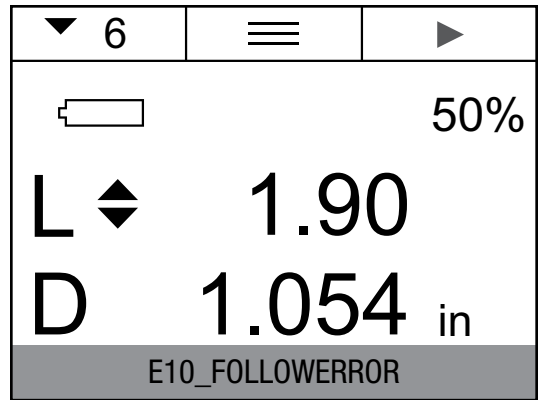
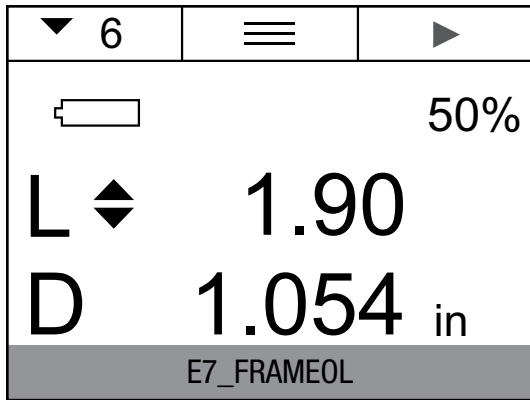

5.6. TOLERANCE

Use tolerances to setup "pass" and "fail" measurements. You may specify a Limit 1 and a Limit 2 to create a tolerance band. Measured results that equal or fall within the range created by the two limits are considered "pass" results. This results will display in BLACK. If the measured result falls outside the band created by the two Limits, the result is considered a "fail" result. A "fail" results displays in RED.

Tolerance	
Enabled	Off
Limit 1	◆ 0.00
Limit 2	◆ 0.00
Sound	None

Tolerance	
Enabled	
On	
Off	

Tolerance Setup Menu

5.6.1. SETTING TOLERANCE LIMITS

When Tolerance is used, you must setup two Limits that define the tolerance range. Enter a value for Limit 1 and Limit 2 making sure your limits are of the same sign for tension or compression.

- Press ▼ Move down to TOLERANCE
- Press ► Select ENABLE if needed or,
- Press ► Select DISABLE if not needed
- Press ▼ Move down to LIMITS
- Press ▼ Move down to LIMIT 1
- Press ► Select Limit 1 value using ▲▼
- Press ◀ Move out of Limit 1
- Press ▼ Move down to LIMIT 1
- Press ► Select Limit 2 value using ▼▲
- Press ◀ Move out of LIMIT 2
- Press ◀ Move out of TOLERANCE

Limit 1	
N	
◆	10.00

Limit 2	
N	
◆	20.00

Tolerance	
Enabled	On
Limit 1	◆ 10.00
Limit 2	◆ 20.00
Sound	None

Tolerance Limits Setup

5.6.2 USING TOLERANCE LIMITS WITH TESTS

When using the Tests feature, two results are displayed- Load and Distance. Therefore, when Tests is enabled, two sets of tolerance limits are displayed and settable within the Tolerance setting.

The method for setting the Limit 1 and Limit 2 are identical to a single result tolerance setup, except you have the option to tolerance based on Load only, Distance only, or on both Load and Distance.

For example, in a Load Limit test, the tolerance would be applied to the Distance result. With Tests enabled and the test type= Load Limit, you will enable Tolerance and then set your two Limits which are based on Distance.

Tolerance	
Enabled	
Load Tol	
Dist Tol	
Sound	None

Tests Tolerance Setup

Tolerance	
Dist Tol	
Limit 1	12.00
Limit 2	22.00

Distance Tolerances for Load Limit Test

5.6.3 USING TOLERANCE LIMITS WITH COF

When using the Coefficient of Friction Averaging mode, we display two COF results: static COF and kinetic COF. Therefore, when COF is enabled, two sets of tolerance limits are displayed and settable within the Tolerance setting.

The method for setting the Limit 1 and Limit 2 are identical to a single result tolerance setup, except you have the option to tolerance based on static COF or kinetic COF.

Modes	
Averaging	
Duration	10.0
Start Force	0.00
Sound	None
Shortfall	On
COF	On

COF Feature is Enabled

Tolerance	
Enabled	On
Limit 1	0.00
Limit 2	0.00
cFs Tol	
cFk Tol	
Sound	None

Set Kinetic COF Tolerance

Limit 2 cFk
0.250

Set COF Kinetic TOL Limit 2

Tolerance	
cFk Tol	
Limit 1	0.100
Limit 2	0.250

Kinetic COF Tolerance Range

5.6.4 SOUNDS

You may configure a SOUND that provides the user with an audible alarm. If the result is "fail", an audible "beep", "chirp" or "tone" may be issued by the force gage. The default is NONE.

- Press ▼ Move down to TOLERANCE
- Press ▼ Move down to SOUNDS
- Press ► Select Sound Type using ▼▲
- Press ◀ Move out of SOUNDS
- Press ◀ Move out of TOLERANCE

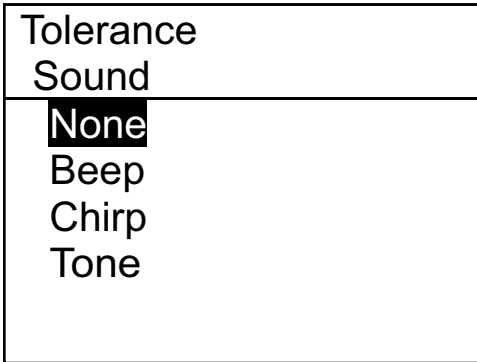

Tolerance Sound Setup

5.7 KEYS SETUP

The DFC Force Gage Softkeys can be mapped to a specific function. Softkey 1 and Softkey 2 may be mapped to perform the following functions:

- Send
- Mode
- Stats
- Save
- Units
- Start/Stop (When connected to the FMM Digital Test Frame)

The center Softkey is always mapped to the SETUP MENU. This softkey cannot be mapped to any other function.

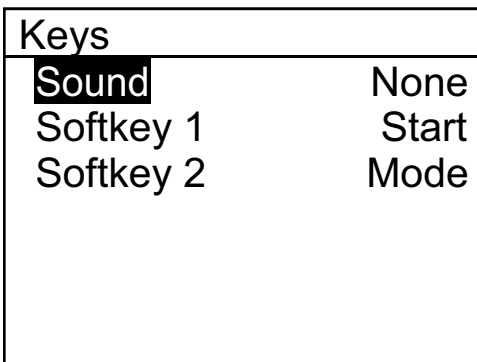

Softkey Setup Menu

5.7.1 SEND FUNCTION

The SEND function is used to send the displayed data to an external device. Data may be sent via Bluetooth®, USB or RS-232. You can specify how you want the Send function to transmit data using the COMMS feature and by specifying the Data Channel.

5.7.2 MODE FUNCTION

The MODE function allows the user to change and select the operating mode for the force gage.

5.7.3 STATS FUNCTION

The STATS function is used when their are results saved in the DFC Force Gage memory. Pressing the STATS softkey will display statistical calculations for the saved results in memory.

5.7.4 SAVE FUNCTION

Use the SAVE function to manually save a result to the DFC memory. When using the DFC Series with the FMM Digital Test Frame and the TESTS feature, results can be automatically saved to memory.

NOTE

Results saved to memory MUST be of the same type. For example, you cannot save tension results and compression results. You can only save either tension or compression.

5.7.5 UNITS FUNCTION

The UNITS function lets the user select and change the unit of measure.

5.7.6 START/STOP FUNCTION (DFC CONTROLLER)

When the DFC is used as a controller with the FMM Digital Force Tester, you must configure one of the softkeys for START/STOP.

To perform a test method, press the softkey labeled START. This will begin the automated test. Once the softkey is pressed, the key function will change to STOP. Pressing Stop during a test method will abort the test.

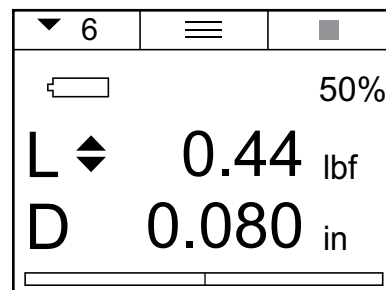

Start/Stop Softkey Mapping

5.7.7 MAPPING SOFTKEY 1

When the display is in Normal view mode (not Flip view mode), the Softkey 1 is the left-most key.

- Press ▼ Move down to KEYS
- Press ► Select Softkey 1
- Press ▼ Select Softkey option list
- Press ► Select Softkey 1 option
- Press ◀ Move out of Softkey 1
- Press ◀ Move out of KEYS

5.7.8 MAPPING SOFTKEY 2

When the display is in Normal view mode (not Flip view mode), the Softkey 2 is the right-most key.

- Press ▼ Move down to KEYS
- Press ▼ Select Softkey 2
- Press ▼ Select Softkey option list
- Press ► Select Softkey 2 option
- Press ◀ Move out of Softkey 2
- Press ◀ Move out of KEYS

5.8 SETTINGS

The Setting menu contains common universal setup options. Each option type is discussed below.

5.8.1 COMMUNICATIONS

The SETUP options for communication are listed below. The diagram shows the various communication methods that may be used with the force gage.

NOTE

1. The L1-CONTROL cable is used exclusively when the DFC is controlling the FMM Test Frame.
2. The USB cable supplied with the force gage is used to communicate with a personal computer. This cable is used for charging the battery; for uploading new features to the force gage; or for exporting data from the force gage to a personal computer.
3. The USB cable is not used for communication between the force gage and the FMM Digital Test Frame.

Protocol	Cable	Where to Use
Bluetooth®		Print via Bluetooth® printer Export data to an external device
USB 2.0	L1-USB	Charge DFC Battery Upload firmware and new features to DFC from a PC Export data to a printer Export data to a PC
RS-232	L1-RS232	Communicate with a serial printer Communicate with a serial external computer or hard drive
Control	L1-CONTROL	Controls the crosshead direction and velocity the FMM from the DFC gage

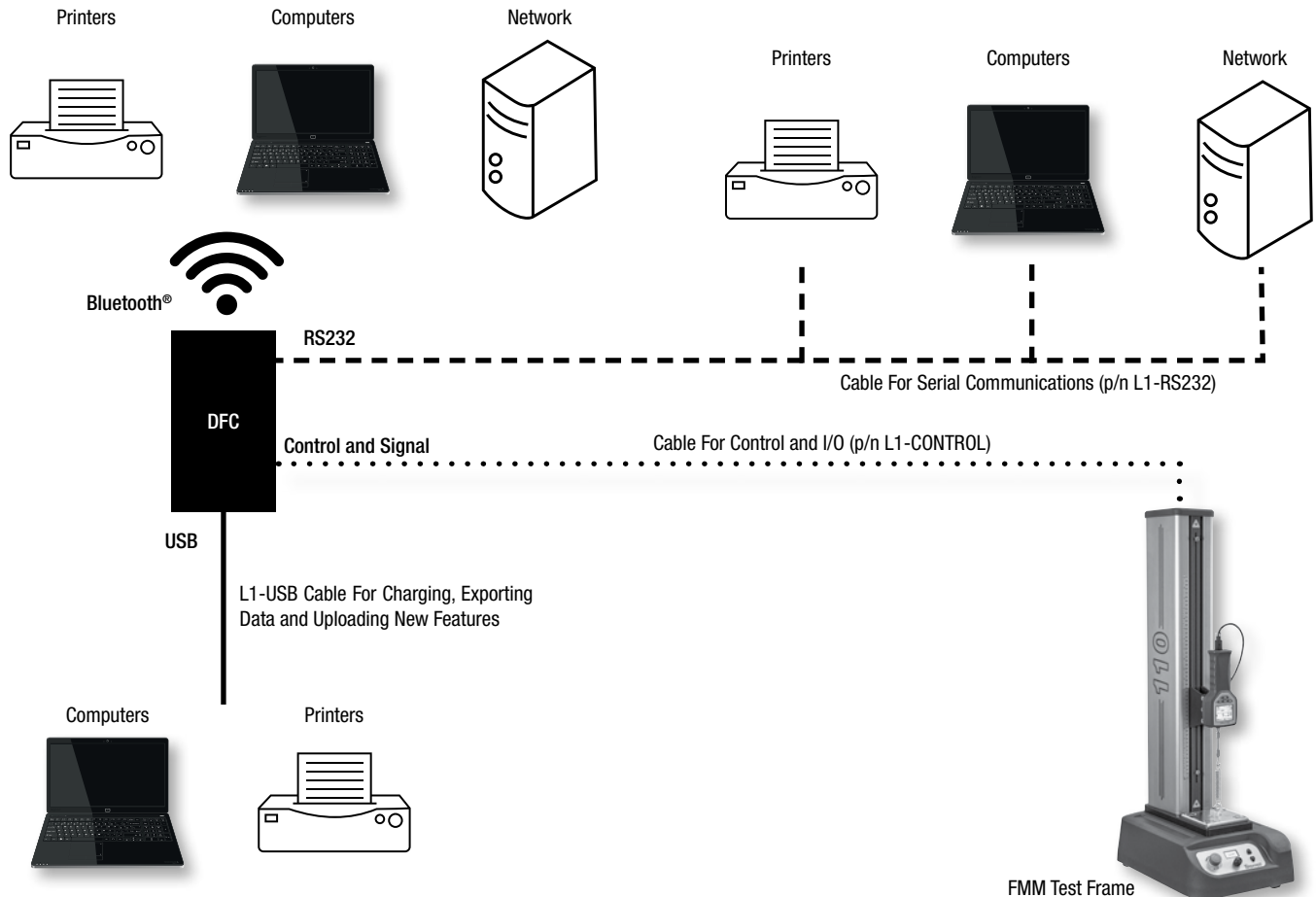

5.8.1.1 USING BLUETOOTH®

The DFC Force Gage is equipped with Bluetooth®. It may communicate to a "paired" and compatible Bluetooth® device, such as a printer.

- Press ▼ Move down to COMMS
- Press ▼ Move down to BT (Bluetooth®)
- Press ► Select ENABLE if needed or,
- Press ► Select DISABLE if not needed
- Press ◀ Move out of BLUETOOTH
- Press ◀ Move out of COMMS

NOTE

1. Bluetooth® will consume battery power significantly. A daily, or more frequent charge time may be required depending on your usage.
2. The DFC Force Gage CANNOT communicate to the FMM Digital Test Frame using Bluetooth®.

5.8.1.2 USING USB 2.0

The DFC Force Gage is equipped with USB 2.0. A mini USB 2.0 connector is located on the base of the gage. The DFC is supplied with a USB 2.0 cable (p/n L1-USB).

Settings	
Comms	
Display	
Filters	20.0
About	
Password	Off
Language	English

Settings	
Comms	
Data Channel	USB
RS-232	Off
Xmit Comp -	On
Xmit Units	On
Xmit TOL	Off

Settings	
Comms	
Data Channel	
USB	
RS-232	
BT	

Data Channel Setup for using USB

The primary use of USB 2.0 with the DFC is for battery charging and for exporting and interfacing to a USB device, such as a personal computer or external drive.

There is no setup required when using USB 2.0.

5.8.1.3 USING RS-232

The FMM Force Tester may be used with the optional RS-232 cable (p/n L1-RS232). The cable features two D-sub connectors for connecting the DFC to a computer or peripheral device using serial communications.

NOTE

1. Use the L1-CONTROL cable when the DFC Series is used to control the FMM Series test frame using the Tests feature.
2. The L1-RS232 cable is used for communicating using RS-232. When the gage is used to export directly to a computer, you may use the RS-232 output from the gage.

- Press ▼ Move down to COMMS
- Press ▼ Move down to RS232
- Press ► Select BAUD RATE needed
- Press ◀ Move out of RS232
- Press ◀ Move out of COMMS

You may configure the BAUD rate for the RS-232 communications. Baud options are: 9600, 19,200, 38,400 and 115,200. The default is 115,200.

Settings	
Comms	
Data Channel	BT
RS-232	Off
Xmit Comp -	On
Xmit Units	On
Xmit TOL	Off

Settings	
Comms	
RS-232	
9600	
19200	
38400	
115200	

RS-232 Setup Menu

NOTE

RS-232 can be used separately and in addition to Bluetooth® and USB.

5.8.1.4 TRANSMIT COMPRESSION - SIGN

You may specify a sign for compression and tension values. If Xmit Comp - is ON, a compression result will use a negative sign to denote a compression value. A tensile result will use a positive sign to denote a tension value.

If Xmit Comp - is OFF, a compression value will use a positive sign to denote a compression value. A tensile result will use a negative sign to denote a tension value.

If Xmit Comp - is NONE, there is no sign used for either a compression or tensile result.

Settings	
Comms	
Data Channel	BT
RS-232	115200
Xmit Comp -	On
Xmit Units	On
Xmit TOL	Off

Settings	
Comms	
Xmit Comp -	
On	
Off	
None	

Xmit Comp -

5.8.1.5 TRANSMIT UNITS

When a result is exported from the force gage to an external device, i.e., a computer, the UNITS may be sent with the measured value. The default is NO. If you want UNITS to be sent, change to YES.

- Press ▼ Move down to COMMS
- Press ▼ Move down to XMIT UNITS
- Press ► Select ENABLE if needed or,
- Press ► Select DISABLE if not needed
- Press ◀ Move out of XMIT UNITS
- Press ◀ Move out of COMMS

Settings	
Comms	
Data Channel	BT
RS-232	115200
Xmit Comp -	On
Xmit Units	On
Xmit TOL	Off

Settings	
Comms	
Xmit Units	
On	
Off	

Transmit Units Setup

5.8.1.6 TRANSMIT TOLERANCES

When a result is exported from the force gage to an external device, i.e., a computer, the values for LIMIT 1 and LIMIT 2 may also sent with the measured value.

- Press ▼ Move down to COMMS
- Press ▼ Move down to XMIT TOLS
- Press ► Select ENABLE if needed or,
- Press ► Select DISABLE if not needed
- Press ◀ Move out of XMIT TOLS
- Press ◀ Move out of COMMS

Settings	
Comms	
Data Channel	BT
RS-232	115200
Xmit Comp -	On
Xmit Units	On
Xmit TOL	Off

Settings	
Comms	
Xmit TOL	
On	
Off	

Transmit Tolerance Setup

5.8.2 DISPLAY

The force gage features a high-resolution 320 x 240 OLED color display. Use the SETUP MENU to configure the following display features.

- Auto Off
- Backlight Intensity
- Display Orientation (Flip)
- Radix

Settings	
Comms	
Display	
Filters	20.0
About	
Password	Off
Language	English

Display Setup Menu

5.8.2.1 USING AUTO OFF

You may configure the force gage to automatically power OFF after an elapsed, specified time duration where the following conditions occur:

- there was no load applied to the load cell sensor
- there was no keypress applied to the keypad

The default is 5 Minutes.

- Press ▼ Move down to DISPLAY
- Press ▼ Move down to AUTO OFF
- Press ► Select Time Duration needed
- Press ◀ Move out of AUTO OFF
- Press ◀ Move out of DISPLAY

Settings	
Display	
Auto Off	5 Min
Backlight	40%
Flip Display	Normal
Radix	Period

Settings	
Display	
Auto Off	
5 Min	
15 Min	
30 Min	
60 Min	

Display Automatic Power Off Setup

5.8.2.2 ADJUSTING BACKLIGHT

The force gage features an adjustable backlight. This is useful to counter issues with low or high ambient light conditions.

The force gage default is 20%. This means the backlight is displayed at 20% of its full intensity/brightness.

NOTE

Battery life is affected by the backlight setting. More power is consumed with a higher backlight setting. At 20% backlight, and normal use, the force gage can provide over 30 hours of use.

- Press ▼ Move down to DISPLAY
- Press ▼ Move down to BACKLIGHT
- Press ► Select Backlight intensity needed
- Press ◀ Move out of BACKLIGHT
- Press ◀ Move out of DISPLAY

Settings Display	
Auto Off	60 Min
Backlight	40%
Flip Display	Normal
Radix	Period

Settings Display Backlight	
20%	
40%	
60%	
80%	

Settings Display Backlight	
40%	
60%	
80%	
100%	

Display Backlight Adjustment

5.8.2.3 USING FLIP FEATURE

The load cell stem extends through the top housing of the force gage. When using an FMM digital force tester, it may be necessary to turn the gage upside down for compression load applications. The "Flip" feature lets you orient the display so it always reads "right-side up".

NOTE

The Softkeys automatically map to the display target regardless of whether the force gage is in Normal or Flip view mode.

- Press ▼ Move down to DISPLAY
- Press ▼ Move down to FLIP
- Press ► Select Yes to invert the display
- Press ◀ Move out of FLIP
- Press ◀ Move out of DISPLAY

Settings Display	
Auto Off	60 Min
Backlight	40%
Flip Display	Normal
Radix	Period

Flip Display Setup

Settings Display Flip Display	
Flip	Normal

Normal Display Setup



Settings Display Flip Display	
Flip	Normal

Flip Display Setup



5.8.2.4 RADIX SETUP

The force gage can use either a period or comma for radix.

- Press ▼ Move down to DISPLAY
- Press ▼ Move down to RADIX
- Press ► Select PERIOD or
- Press ▼ Select COMMA
- Press ◀ Move out of RADIX
- Press ◀ Move out of DISPLAY

Settings	
Display	
Auto Off	60 Min
Backlight	40%
Flip Display	Normal
Radix	Period

Settings	
Display	
Radix	
Period	
Comma	

Settings	
Display	
Radix	
Period	
Comma	

Filters Setup Menu

5.8.3 USING FILTER

Filtering can be used to compensate for noisy test measurements and to help dampen or smooth a reading and results. The DFC features an internal sampling rate of 20kHz, ideal for capturing peak loads on brittle materials. Since most tests do not require this sample frequency, you may use filters for the displayed information or for measuring maximum loads.

NOTE

High sampling should only be used for short test durations on brittle materials. Sampling at 100Hz is sufficient for most force measurement applications.

Settings	
Comms	
Display	
Filters	20.0
About	
Password	Off
Language	English

Filters	
Hz	
1	

Filters	
Hz	
1000	

Filters Setup Menu

5.8.4 ABOUT

The About section is a view only that shows basic gage information:

- Model Number
- Gage Capacity
- Serial Number
- Firmware Revision
- Overload Count

Settings	
Comms	
Display	
Filters	1000.0
About	
Password	Off
Language	English

Settings	
About	
About	
Set Defaults	

DFC	
500 N 100 lb	
S/N	12345678
Firmware	00.02.04
Battery %	
Overloads	0

Settings	
About	
About	
Set Defaults	

About Display

The About display may also be used to set the Factory Defaults for your force gage.

Force Gage Default Settings	
Setting	Default
Mode	Real Time
Units	N (Newtons)
Memory	0
Tests	Off
Tolerance	Off
Softkey 1	Units
Softkey 2	Mode
Data Channel	RS-232
RS-232	115,200
Xmit Comp -	Yes
Xmit Units	Off
Xmit TOL	Off
Auto Off	5 Minutes
Backlight	40%
Flip Display	Normal
Radix	Period
Password	Off
Language	English

5.8.5 USING A PASSCODE

A Password may be used to restrict unauthorized access to the DFC setup menu.

Your Starrett representative will provide you with your Passcode.

If a Password is enabled, the user is required to enter the Passcode. Only users with the Pass Code can access the force gage menu and options.

- Press ▼ Move down to PASSWORD
- Press ► Select Pass Code
- Press ▲▼ to create a Pass Code number
- Press ◀ Move out of PASSWORD

NOTE

The passcode is not configurable. The passcode is assigned to you by your Starrett representative.

When the Password = ON, the force gage menu cannot be accessed.

Settings	
Comms	
Display	
Filters	1000.0
About	
Password	Off
Language	English

Settings	
Password	
On	
Off	

Changes to the gage cannot be made until the Passcode number is entered. The gage will display "Settings Locked".

Settings Locked

Once the Passcode number is entered, the user must go immediately to the Password menu and change the Password setting to OFF.

Enter Password
0

Passcode Entry

5.8.6 SELECTING DISPLAY LANGUAGE

The force gage will display terms in the following languages. To select the desired display language, go to **SETUP MENU>LANGUAGES**. Select the language from the list.

- Press ▼ Move down to LANGUAGE
- Press ► Select Display Language list
- Press ► Select LANGUAGE needed
- Press ◀ Move out of LANGUAGE

Settings	
Comms	
Display	
Filters	1000.0
About	
Password	Off
Language	English

Settings	
Language	
English	
Deutsch	
Espanol	
Portugues	
Francais	

Settings	
Language	
Italiano	
中文	
Русский	
Polski	
Čech	

Language Setup Menu

6.0 DFC FORCE GAGE ACCESSORIES

Starrett can supply all types of testing fixtures, grips and accessories for your force measurement systems and instruments. We can also design and manufacture custom testing fixtures to your exact requirements. Contact Starrett for assistance.

Included in this section are common accessories used with your force gage.

ACCESSORY KITS

Each force gage is supplied with a complete accessory kit. The accessory kit includes a hook, notch, chisel, flat, and point adapter. A 6-inch extension rod is included. The adapter material and thread size correspond to the force's gage rated capacity.

NOTE

Force gages with full scale capacities of 2 lbf (10N) and 5 lbf (20 N) have accessories made of aluminium. All other capacities have accessories made of stainless steel.

Included with the force gage is a carrying case, USB cable, a User Guide and Certificate of Calibration.



STANDARD FORCE GAGE ACCESSORIES

Accessories	Order No.	Material	Thread	DFC-2	DFC-5	DFC-10	DFC-20	DFC-50	DFC-100	DFC-200	DFC-500	SPK-FG-A	SPK-FG-S	SPK-FG-M	SPK-FG-L
Carrying Case	L1-FG-CASE	-	-	●	●	●	●	●	●	●	●				
USB Cable	L1-USB	-	-	●	●	●	●	●	●	●	●				
Flat Adapter, Small	MLX-FLAT-A	Aluminum	M6 x 1-6H	●	●							□			
Flat Adapter, Small	MLX-FLAT-S	Stainless Steel	M6 x 1-6H			●	●	●	●	●			□	□	
Flat Adapter, Large	MLX-FLAT-L	Stainless Steel	M10 x 1.5-6H								●				□
Point Adapter, Small	MLX-POINT-A	Aluminum	M6 x 1-6H	●	●							□			
Point Adapter, Small	MLX-POINT-S	Stainless Steel	M6 x 1-6H			●	●	●	●	●			□	□	
Point Adapter, Large	MLX-POINT-L	Stainless Steel	M10 x 1.5-6H								●				□
V-notch Adapter, Small	MLX-NOTCH-A	Aluminum	M6 x 1-6H	●	●							□			
V-notch Adapter, Small	MLX-NOTCH-S	Stainless Steel	M6 x 1-6H			●	●	●	●	●			□	□	
V-notch Adapter, Large	MLX-NOTCH-L	Stainless Steel	M10 x 1.5-6H								●				□
Chisel Adapter, Small	MLX-CHISEL-A	Aluminum	M6 x 1-6H	●	●							□			
Chisel Adapter, Small	MLX-CHISEL-S	Stainless Steel	M6 x 1-6H			●	●	●	●	●			□	□	
Chisel Adapter, Large	MLX-CHISEL-L	Stainless Steel	M10 x 1.5-6H								●				□
Hook, Xtra Small	MLX-HOOK-XS	Aluminum	M6 x 1-6H	●	●							□			
Hook, Small	MLX-HOOK-S	Stainless Steel	M6 x 1-6H			●	●	●	●	●			□	□	
Hook, Medium	MLX-HOOK-M	Stainless Steel	M6 x 1-6H												
Hook, Large	MLX-HOOK-L	Stainless Steel	M10 x 1.5-6H								●				□
6" Extension Rod, Small	MLX-ROD-A6	Aluminum	M6 x 1-6H	●	●							□			
6" Extension Rod, Small	MLX-ROD-S6	Stainless Steel	M6 x 1-6H			●	●	●	●	●			□	□	
6" Extension Rod, Large	MLX-ROD-L6	Stainless Steel	M10 x 1.5-6H								●				□

OPTIONAL ACCESSORIES

Extension Rods	Order Number	Thread Size
Extension Rod, Aluminum, 1-inch	MLX-ROD-A1	M6 x 1-6H
Extension Rod, Stainless Steel, 1-inch	MLX-ROD-S1	M6 x 1-6H
Extension Rod, Aluminum, 2-inch	MLX-ROD-A2	M6 x 1-6H
Extension Rod, Stainless Steel, 2-inch	MLX-ROD-S2	M6 x 1-6H
Extension Rod, Stainless Steel, 2-inch	MLX-ROD-L2	M10 x 1.5-6H

Clevis Accessories	Order Number	Thread Size
Clevis Adapter, Aluminum	MLX-CLEVIS-FA-M6	M6
Clevis Adapter, Stainless Steel	MLX-CLEVIS-FS-M6	M6
Clevis Adapter, Stainless Steel	MLX-CLEVIS-FS-M10	M10
Locking Ring, Aluminum	MLX-RING-A	M20
Locking Ring, Stainless Steel	MLX-RING-S	M24
Grip Pin, Aluminum	MLX-PIN-A	-
Grip Pin, Stainless Steel	MLX-PIN-S	-
Spanner Wrench	L1-SPANNER	-
Cable, RS-232, 6 ft. (2m)	L1-RS232	-
Cable, Control DFC to FMM, 6ft. (2m)	L1-CONTROL	-



FEMALE-TO-MALE THREAD ADAPTERS

Order Number	Length	Thread A	Thread B
MLX-25043	0.75 inch	#10-32 UNF-2B	M6 x 1-6g
MLX-25044	0.75 inch	M6 x 1-6H	#10-32 UNF-2A
MLX-25045	0.75 inch	1/4-28 UNF-2B	M6 x 1-6g
MLX-25046	0.75 inch	M6 x 1-6H	1/4-28 UNF-2A
MLX-25047	1.00 inch	5/16-18 UNC-2B	M6 x 1-6g
MLX-25048	0.875 inch	M6 x 1-6H	5/16-18 UNC-2A
MLX-25049	1.125 inch	5/16-18 UNC-2B	M10 x 1.5-6g
MLX-25050	1.25 inch	M10 x 1.5-6H	5/16-18 UNC-2A
MLX-25051	1.25 inch	1/2-20 UNF-2B	M10 x 1.5-6g
MLX-25052	1.25 inch	M10 x 1.5-6H	1/2-20 UNF-2A

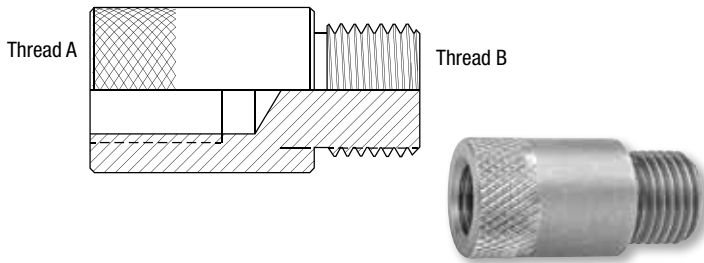

SET SCREWS

Order Number	Length	Thread A
MLX-50000545	1.00 inch	#10-32 UNF-2A
MLX-50000546	1.00 inch	1/4-28 UNF-2A
MLX-50000547	1.00 inch	5/16-18 UNF-2A
MLX-50000548	1.00 inch	1/2-20 UNF-2A
MLX-51000195	20mm	M4 x 0.7-6g
MLX-51000187	25mm	M6 x 1-6g
MLX-51000188	25mm	M10 x 1.5-6g
MLX-51000196	25mm	M12 x 1.75-6g

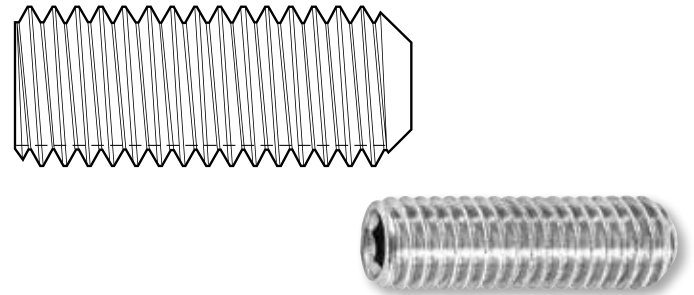

MALE-TO-MALE THREAD ADAPTERS

Order Number	Length	Thread A	Thread B
MLX-25053	0.75 inch	M4 x 0.7-6g	M6 x 1-6g
MLX-25054	0.875 inch	M10 x 1.5-6g	M6 x 1-6g
MLX-25055	0.75 inch	#10-32 UNF-2A	1/4-28 UNF-2A
MLX-25056	0.875 inch	#10-32 UNF-2A	5/16-18 UNC-2A
MLX-25057	0.875 inch	5/16-18 UNC-2A	1/4-28 UNF-2A
MLX-25058	0.875 inch	1/4-28 UNF-2A	1/2-20 UNF-2A
MLX-25059	1.00 inch	5/16-18 UNC-2A	1/2-20 UNF-2A
MLX-25060	0.75 inch	#10-32 UNF-2A	M6 x 1-6g
MLX-25061	0.75 inch	1/4-28 UNF-2A	M6 x 1-6g
MLX-25062	1.00 inch	5/16-18 UNC-2A	M10 x 1.5-6g
MLX-25063	1.00 inch	1/2-20 UNF-2A	M10 x 1.5-6g

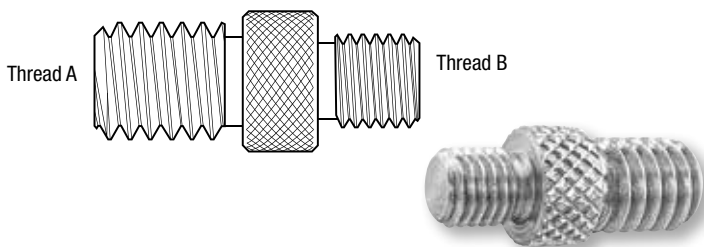

THREAD COUPLERS

Order Number	Length	Thread A	Thread B
MLX-25037	0.75 inch	#10-32 UNF-2B	1/4-28 UNF-2B
MLX-25038	0.75 inch	#10-32 UNF-2B	M6 x 1-6H
MLX-25039	1.00 inch	5/16-18 UNF-2B	M6 x 1-6H
MLX-25040	0.75 inch	1/4-28 UNF-2B	M6 x 1-6H
MLX-25041	1.25 inch	5/16-18 UNF-2B	M10 x 1.5-6H
MLX-25042	1.25 inch	1/2-20 UNF-2B	M10 x 1.5-6H
MLX-25064	0.75 inch	M6 x 1-6H	M6 x 1-6H
MLX-25065	1.25 inch	M10 x 1.5-6H	M10 x 1.5-6H
MLX-25066	0.75 inch	#10-32 UNF-2B	#10-32 UNF-2B
MLX-25067	0.75 inch	1/4-28 UNF-2B	1/4-28 UNF-2B
MLX-25068	1.00 inch	5/16-18 UNC-2B	5/16-18 UNC-2B
MLX-25069	1.25 inch	1/2-20 UNF-2B	1/2-20 UNF-2B

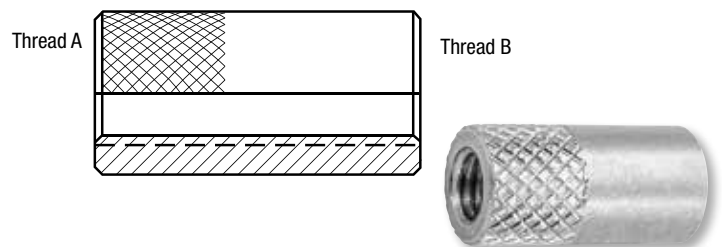

7.0 CABLE PINOUT

Pin Number (Male)	Wire Color	Signal Name	Pin Number (Female)
1	Black	OUT_0	NC
2	Brown	TX_OUT	2
3	Red	RX_IN	3
4	Orange	External voltage In (5-24V)	NC
5	Yellow	GND	5
6	Green	IN_1	NC
7	Blue	VCC(+5V) 125ma	NC
8	Violet	OUT_1	NC
9	Grey	VCC_IN	NC

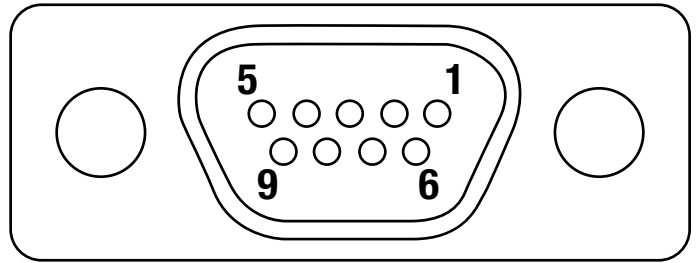

L1-RS232 Cable

Pin Number (Male)	Wire Color	Signal Name	Pin Number (Male)
1	Black	OUT_0	1
2	Brown	TX_OUT	2
3	Red	RX_IN	3
4	Orange	External voltage In (5-24V)	4
5	Yellow	GND	5
6	Green	IN_1	6
7	Blue	VCC(+5V) 125ma	7
8	Violet	OUT_1	8
9	Grey	VCC_IN	9

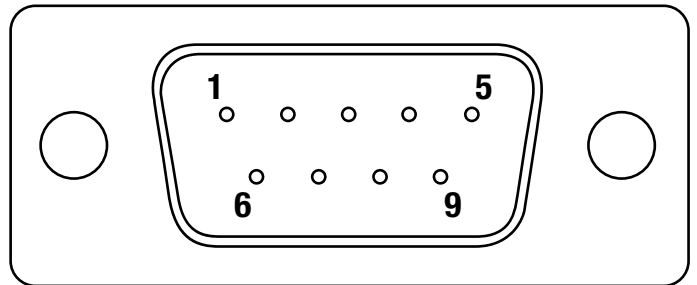

L1-CONTROL Cable

NORTH AMERICA

WWW.STARRETT.COM

ATHOL, MA, USA, 01331-1915

EUROPE & ASIA

WWW.STARRETT.CO.UK

JEDBURGH, SCOTLAND, TD8 6LR

SOUTH & CENTRAL AMERICA

WWW.STARRETT.COM.BR

13306-900, ITU, SP, BRASIL

CNPJ 56.994.700/0001-01

CHINA

WWW.STARRETT.COM.CN

USER MANUALS AVAILABLE ONLINE

AT STARRETT.COM

Starrett.com