

**Fowler**<sup>®</sup>

HIGH PRECISION

baty



OPTICAL INSTRUMENTS VISION SYSTEMS

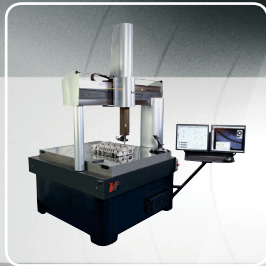

# CONTENTS

## Page Number



### Vision Systems

VuMaster 2D Manual / 2D CNC	3
Venture Touch	4
Venture 3D CNC	5
Venture Options	6
Venture Plus	7 - 8



### Software

Fusion Software	9 - 10
-----------------	--------

### Fixtures

Flexmaster Fixtures	11
---------------------	----

### Technical Specifications

12 - 13

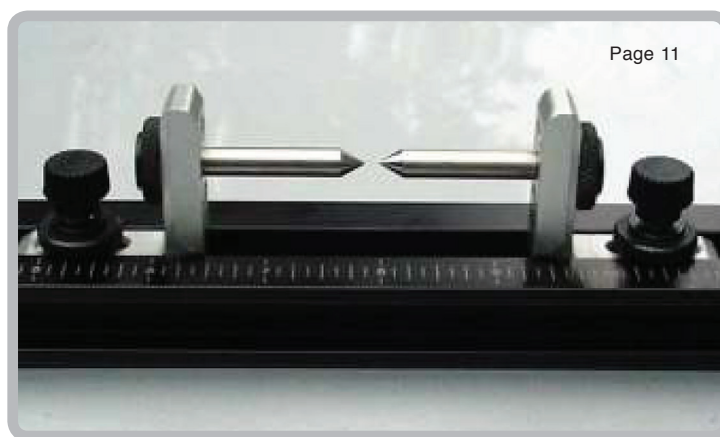
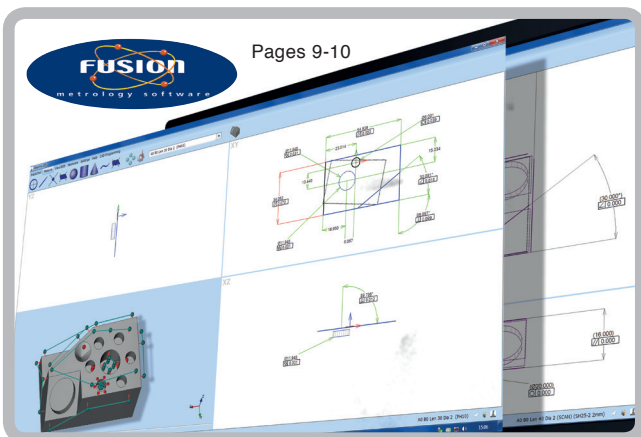

## Fowler Baty Vision Systems - VuMaster 2D Manual / 2D CNC

VuMaster is a 2D vision system with a massive difference.

Due to its innovative absolute 2D scale system, expertly designed VuMaster does not have a conventional moving stage or encoders - just a floating measuring camera that moves anywhere in the measuring range. The result is fast, accurate, 'non contact' measurement over a much larger measuring range - 400mm x 300mm to be exact!

Because the camera moves and the part stays still, there is often no need for expensive and time consuming work holding devices.

VuMaster is either operated manually or inspection routines can be recorded and stored. When played back, these 'programs' guide the operator through a pre-defined inspection procedure recreating the same lighting conditions and using Video Edge Detection to automatically capture feature data.

Finally, a report is generated in the form of a fully dimensioned drawing of the measured part.

### Features

- Large 15.7"/400mm x 11.8"/300mm measuring range
- Sturdy construction with a granite base
- Supplied with Fusion 2D vision software
- Colourmap measuring technology
- Programmable collimated profile lighting
- Teach and repeat part programming
- Advanced video edge detection
- Digital zoom
- Supplied with stand, rack mount PC and 22" monitor
- Programmable segmented LED surface ring light
- Motorised autofocus
- Image grab
- Auto inspection playback
- CNC and Manual models available



54-403-001-0

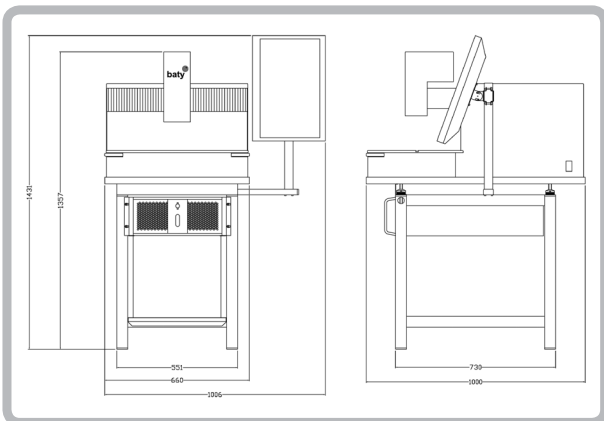

### VUMASTER

Part Number	Description
54-403-001-0	VuMaster Manual including 22" LCD monitor
54-403-005-0	VuMaster CNC including 22" LCD monitor
54-251-500-0	Glass calibration artifact

## Fowler Baty Vision Systems - Venture Touch

The highly successful Venture range includes both manual and full CNC systems that cover two standard measuring ranges.

### Venture Touch 3D

This advanced Vision system combines a manually operated X-Y measuring stage with a motorised Z axis. The advantage of this is that the servo motor driven Z axis can provide the all-important autofocus function for Z axis measurement without operator influence.

Suitable for the shop floor, the rugged design features a steel / granite stand with fully integrated PC controller running Baty's 3 axis touch screen software - Fusion Touch. The full HD touch screen is mounted on an adjustable arm and the software is arranged in a portrait layout for ease of use.

Fusion Touch software features full geometric functionality so circles, lines arcs and points can be measured using dedicated tools. Data points are automatically taken along the edge of the feature using video edge detection, then all measurements are automatically saved, should the inspection need to be replayed for a batch of parts.

All measured features appear in the part view where they can be selected for dimensioning resulting in a dimensioned part view that can be printed or exported to CAD. Tolerances are set for each dimension so that the final inspection reports can classify each dimension as a pass or fail.

### Inspection playback

During this process the operator is guided through the inspection routine via the graphical part view. Once the stage has been positioned so that the feature appears in the camera's view, the Video Edge Detection tools take over and measure the feature automatically. If features are on different planes, the Z axis drives under CNC control to the correct position as defined by the original inspection. All lighting and magnification conditions are also recorded and re-created as each feature is visited. The end result is a highly repeatable process with no operator influence.

### Lighting

The programmable LED lighting is also controlled using the touch screen. Segmented surface illumination, through the lens and profile lighting conditions can be adjusted to ensure that the feature edge is perfectly illuminated.

### Features:

- High resolution 0.5µm scales for increased accuracy
- 6.5:1 zoom optics (with optional CNC control)
- Optional 12x zoom optics
- Programmable segmented LED lighting system
- Z axis dovetail slide mount for increased Z axis capacity
- High precision cross-roller stage
- Ultra-smooth plain rod drives
- Auto video edge detection tools
- Auto programming
- Motorised autofocus



54-251-150-0

## VENTURE TOUCH

Part Number	Description
54-251-150-0	Venture Touch - 2510, Venture manual with motorized Z and autofocus, Fusion Touch software, 9.8"/250mm x 4.9"/125mm x 6.1"/155mm X,Y, Z measuring range
54-303-250-0	Venture Touch - 3030, Venture manual with motorized Z and autofocus, Fusion Touch software, 11.8"/300mm x 11.8"/300mm x 7.8"/200mm X,Y, Z measuring range
54-251-500-0	Glass calibration artifact
54-251-550-0	All steel machine stand with granite top

## Fowler Baty Vision Systems - Venture 3D CNC

Venture CNC models take the power of Fusion software one stage further by completely automating the inspection process. Now advanced features like scanning and best fitting can be done quickly without taking up the time of skilled operators.

CNC programming is a simple teach and repeat process. Just measure the part once and a full CNC program is created automatically. The zoom lens can also be controlled so that magnification changes are all recorded into the program.

### Large Measurement Volume

The use of a touch probe is optimized on a CNC system. Measurements from data points can be taken using the touch probe can be combined with those taken using Video Edge Detection for optimum speed and reduced inspection times.

A probe changer rack can be installed so that the probe modules fitted with a variety of pre-calibrated styli can also be used in the same inspection. When a change of stylus is required, the system automatically puts the current probe module back in the rack and picks up the next to continue the inspection process.

When programming using the touch probe, use only the minimum points required to define each element. Then simply edit in the optimum number of points for each element. The new probe path is then automatically created when the program is played, cutting down both programming and inspection time.

Alternatively, features can be programmed directly from an imported 3D CAD model.

### Standard CNC system features include:

- Teach and repeat programming
- Programmable segmented LED lighting
- 6.5:1 zoom optics (with optional CNC control)
- Optional 12x zoom optics
- High resolution 0.5 $\mu$ m scales for increased accuracy
- CAD import/export
- Scanning and best fitting
- Fully dimensioned part view
- SPC included
- Once click output to Excel™
- Autofocus
- 6.3"/160mm or 7.8"/200mm Z axis measuring range on adjustable dovetail slide
- 9.8"/250mm x 4.9"/125mm and 11.8"/300mm x 11.8"/300mm XY stages available
- Auto 2D program from CAD



Fowler Baty's Programmable segmented LED lighting

Part Number	Description
54-251-200-0	Venture 2510 - CNC, Venture CNC with Fusion 3D software, 9.8"/250mm x 4.9"/125mm x 6.1"/155mm XYZ stage, includes PC and 2, 19" monitors
54-251-205-0	Venture XT 2510 - CNC, Venture CNC with Fusion 3D software, 9.8"/250mm x 4.9"/125mm x 6.1"/155mm XYZ stage, includes PC and 2, 19" monitors, TP20 touch probe and CNC zoom lens
54-303-300-0	Venture XT - CNC, Venture CNC with Fusion 3D software, 11.8"/300mm x 11.8"/300mm x 7.8"/200mm XYZ stage, includes Controller and 2, 19" monitors
54-242-000-0	Venture XT 3030 - CNC with TP20 options, 11.8"/300mm x 11.8"/300mm x 7.8"/200mm XYZ stage
54-242-500-0	Venture XT 3030 - CNC with SP25 options, 11.8"/300mm x 11.8"/300mm x 7.8"/200mm XYZ stage
54-251-500-0	Glass calibration artifact
54-251-020-0	Touch probe kit includes incl ref ball, module and stylus

# VISION SYSTEMS

## Venture Options

### CAD Comparison

3D CAD models (STEP or IGES format) can be imported and displayed in a floating window. Following a simple part coordinate alignment to the CAD model, data points can be taken anywhere on the part surface using either touch probe or Vision. These data points are then displayed on the CAD model and classified according to their distance from the nominal surface for 3D profile analysis.

### CAD Programming

Touch probe inspection programs can be created before the part is even manufactured by using the CAD model to define the features to be measured. The CNC program template is then created with all the necessary XYZ moves calculated. This facility can also be used for offline programming on a remote PC.

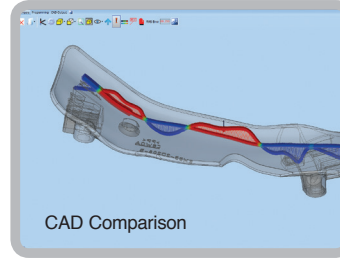

### 54-303-196-0

Cast vee blocks and extended centres for the 2510 and 3030 Venture models.

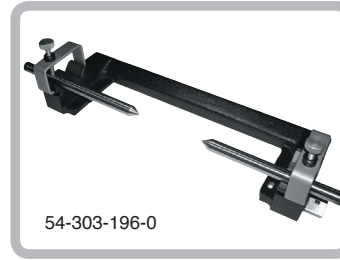

### 54-303-200-0

Universal fixture base provides fixture mounting slots compatible with all projector accessories.

### 54-250-550-0

Rigid steel stand with granite top and integral PC / controller shelf for Venture 2510 and 3030 models.



### 54-251-500-0

Included with every Venture is this calibration standard with nominal diameters for field of view measurement verification and pixel calibration.

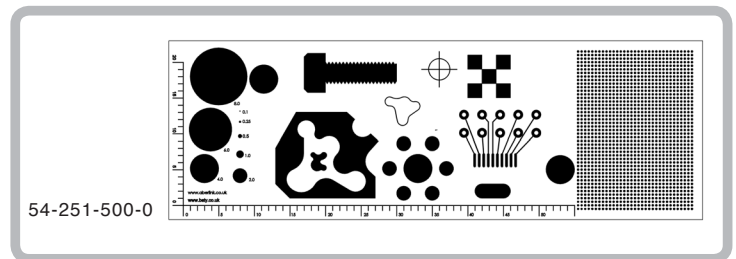

## VENTURE OPTIONS

Part Number	Description
54-303-314-0	CAD comparison software
54-303-016-3	Probe module change rack - 6 port
54-303-196-0	Dual vee block and centers
54-303-200-0	Universal fixture base
54-251-500-0	Glass calibration artifact
54-251-550-0	All steel machine stand with granite top

## Fowler Baty Vision Systems - Venture Plus

The Venture Plus range includes all of the standard Venture features with a little more... measuring range.

### Large Measurement Volume

The Venture Plus is available in four models:

#### 54-303-646-0

25.2"/640mm x 11.2"/600mm x 9.8"/250mm measuring range

#### 54-303-649-0

25.2"/640mm x 35.4"/900mm x 9.8"/250mm measuring range

#### 54-303-110-0

39.4"/1000mm x 39.4"/1000mm x 15.7"/400mm measuring range

#### 54-303-150-0

39.4"/1000mm x 59"/1500mm x 15.7"/400mm measuring range

The bridge type construction is all aluminium resulting in low inertia and low thermal mass. Air bearings are used on all axes and a granite Y beam is used for increased accuracy. This ensures that the machine will expand and contract uniformly with temperature changes ensuring minimal distortion and subsequent errors. Ambient temperature can be

compensated for within the Fusion software making the Venture Plus ideal for use on the shop floor.

Complete with our standard zoom optics and programmable, segmented LED surface lighting, Venture Plus offers the same level of camera based functionality as every other Venture.

The use of a touch probe is optimised on a CNC system. Measurements from data points taken using the touch probe can be combined with those taken using Video Edge Detection for optimum speed and reduced inspection times.

A probe changer rack can be installed so that probe modules fitted with a variety of pre-calibrated styli can also be used in the same inspection. When a change of stylus is required, the system automatically puts the current probe module back in the rack and picks up the next to continue the inspection process. Only now can this functionality be combined with traditional touch probe technology to offer the ultimate in large format multi-sensing Vision systems - Venture Plus.

### Standard CNC System Features Include:

- Teach and repeat programming
- Programmable segmented LED lighting
- High resolution 0.5µm scales for increased accuracy
- CAD import / export
- Scanning and best fitting
- Fully dimensioned part view
- SPC included
- One click output to Excel™
- Autofocus
- Renishaw TP20 touch probe joint
- Integrated machine stand

### Venture Plus additional features include:

- Rigid, low mass bridge construction
- Integral 6.5:1 zoom optics
- Includes PC controller
- CNC controlled collimated profile lighting
- 250/400mm Z axis measuring range
- Optional automatic temperature compensation
- Optional multi function joystick with colour touch screen display

### Options include:

- Multi-function joystick with colour touch screen
- 12:1 zoom optics
- Renishaw SP25 scanning probe



# VISION SYSTEMS

## Fowler Baty Vision Systems - Venture Plus

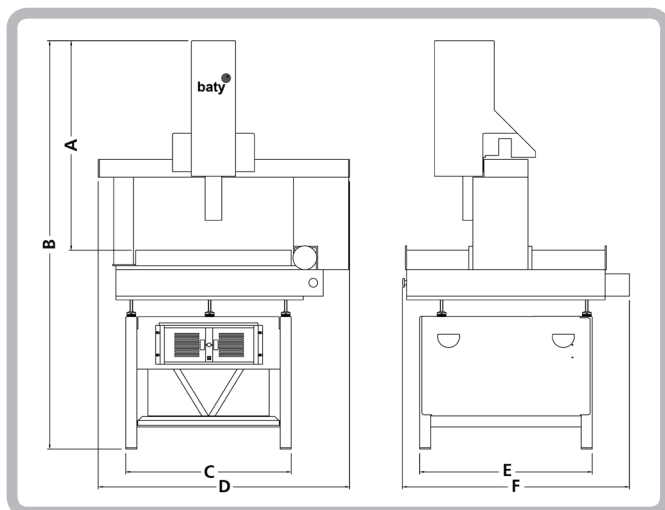

54-303-110-0

Part Number	Dim. A	Dim. B	Dim. C	Dim. D	Dim. E	Dim. F
54-303-646-0	37.4"/950mm	72.8"/1851mm	29.5"/750mm	44.8"/1140mm	30.8"/783mm	40.5"/1030mm
54-303-649-0	33.4"/850mm	72.8"/1851mm	29.5"/750mm	44.8"/1140mm	42.6"/1083mm	52.3"/1330mm
54-303-110-0	56.7"/1440mm	88.5"/2250mm	54.3"/1380mm	57.8"/1470mm	53.1"/1350mm	57.8"/1470mm
54-303-150-0	56.7"/1440mm	88.5"/2250mm	54.3"/1380mm	57.8"/1470mm	72.8"/1850mm	77.5"/1970mm

### VENTURE PLUS

Part Number	Description
54-303-646-0	Venture Plus - 25.2"/640mm x 11.2"/600mm x 9.8"/250mm
54-303-649-0	Venture Plus - 25.2"/640mm x 35.4"/900mm x 9.8"/250mm
54-303-110-0	Venture Plus - 39.4"/1000mm x 39.4"/1000mm x 15.7"/400mm
54-303-150-0	Venture Plus - 39.4"/1000mm x 59"/1500mm x 15.7"/400mm



## Fusion Software

Fusion metrology software has been the foundation for Baty's camera based inspection systems for the last decade. The combination of ease of use, Advanced Edge Detection and graphical reporting has established this remarkable software as the standard by which other vision packages are measured.



### Dimensioned Part View

Measured results are displayed in the form of a fully dimensioned drawing. Dimensions within the specified tolerance are shown in green whilst dimensions out of tolerance are shown in red for immediate visual status of the measured part.

Geometric tolerances can also be displayed using the standard drawing practice. The final dimensioned part view can then be printed as an engineering drawing with a traditional drawing frame containing company details, customer and part details, date and inspection name.

### SPC Included

Baty Fusion software will also display SPC batch information for multiple components. Information given includes maximum value in batch, minimum value, user definable sigma value, CPK value, mean shift and also plots two different charts of the batch data.

### Easy Reporting

In addition to the graphical representation above, detailed reports can be instantly created showing the feature name, nominal dimension, actual, error, upper and lower limits and a green pass or red fail label for each measured dimension in tabulated format. Geometric tolerance details can also be displayed along with a thumbnail view of the part and batch/customer information. The entire report can be duplicated as an Excel workbook for email.

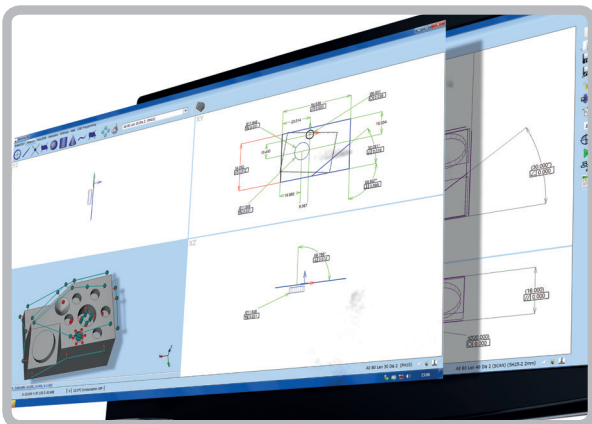
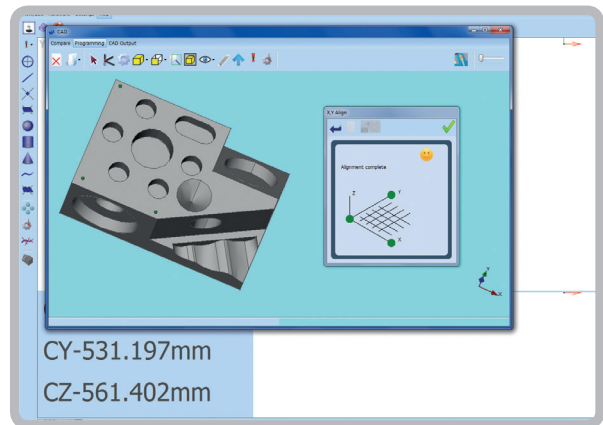
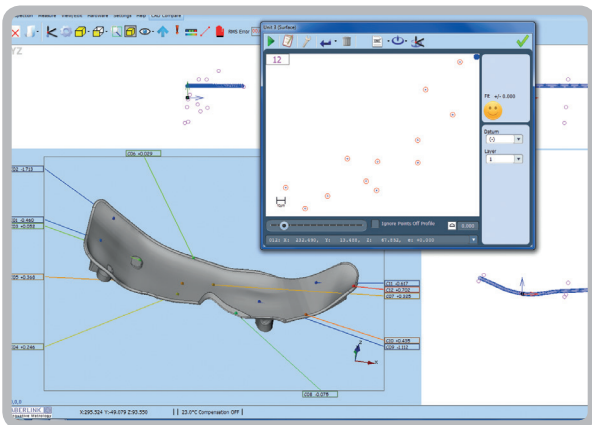

Baty International											
Drawing No.	52774-4	Order No.		Date	28-Oct-04 18:50						
Title	Element Blade	Serial No.		Inspector	DAW						
Customer	Bobby	Material		Notes							
Identifier	Dimension	Nominal	Actual	Dim. Error	Upper	Lower	Pass/Fail	Geometric Tolerance	Actual	Limit	Pass/Fail
T 2°Circle		Ø7.5000	Ø7.4995	-0.0005	Ø7.5005	Ø7.4995	PASS	0.0005	0.0005		PASS
190 5mm Circle True Position							PASS	0.0009	0.0020		PASS
X pos'n		0.0000	0.0000	0.0000							
V pos'n		0.0000	0.0000	0.0000							
1°Circle		Ø1.0000	Ø1.0003	0.0003	Ø1.0005	Ø1.0000	PASS	0.0008	0.0020		PASS
1°Circle		Ø1.0000	Ø1.0003	0.0003	Ø1.0005	Ø1.0000	PASS	0.0009	0.0020		PASS
1°Circle		Ø1.0000	Ø1.0003	0.0003	Ø1.0005	Ø1.0000	PASS	0.0009	0.0020		PASS
1°Circle		Ø1.0000	Ø1.0004	0.0004	Ø1.0005	Ø1.0000	PASS	0.0008	0.0020		PASS
1°Circle		Ø1.0000	Ø1.0005	0.0005	Ø1.0005	Ø1.0000	PASS	0.0009	0.0020		PASS
1°Circle		Ø1.0000	Ø1.0004	0.0004	Ø1.0005	Ø1.0000	PASS	0.0009	0.0020		PASS
25 4mm Circle True Position								0.0011	0.0005		Fail
X pos'n		0.0000	-0.0002	-0.0002							
V pos'n		3.7493	3.7498	0.0005							
25 4mm Circle True Position								0.0010	0.0005		Fail
X pos'n		3.2469	3.2472	0.0003							
V pos'n		1.8746	1.8752	0.0006							
25 4mm Circle True Position								0.0015	0.0005		Fail
X pos'n		3.2460	3.2476	0.0007							
V pos'n		-1.9745	-1.9745	0.0001							

## Fusion Software

### Video Edge Detection

Video Edge Detection (VED) ensures a repeatable result without relying on the skill of the operator. Hundreds of data points can be taken in an instant to calculate standard geometric features. Standard VED tools include arc, circle, line, point, focus and curve.

### Image Stitching and Profile Scanning

A camera image can be taken and stored every time the XY stage is paused. These images may be 'stitched' together to allow the user to zoom out and view the entire component in the camera image view. Imported dxf files may be used as overlays which can be super imposed on top of the stitched image, providing a visual comparison of the entire part to the tolerance bands shown on the dxf. If a profile measurement is required the curve tool can be used to automatically trace the profile of the part. The resulting data-point cloud can then be viewed both in the part view for reporting as well as the stitched camera image. A profile dimension can easily be added to define the best fit profile error. Image stitching can also be used to quickly grab all of the features of a large 2D component. A CNC inspection routine can then be created by simply clicking on the features to be measured using the 'one click feature' or 'all features in area' tools.

### Touch Probe Compatible

Fusion metrology software is ready to accept touch probe measurements as well as camera based. Offsets for each measuring system can be calculated enabling the combination of non-contact measurements in the same inspection. An optional probe storage rack can also be used to allow automatic probe changes mid program. For touch probe scanning applications, Renishaw's SP25 scanning probe option can be specified.

The CNC option enables fully automatic part inspection with teach and repeat programming and manual joystick control. Parts can be palletised for batch inspection and reports are generated automatically.

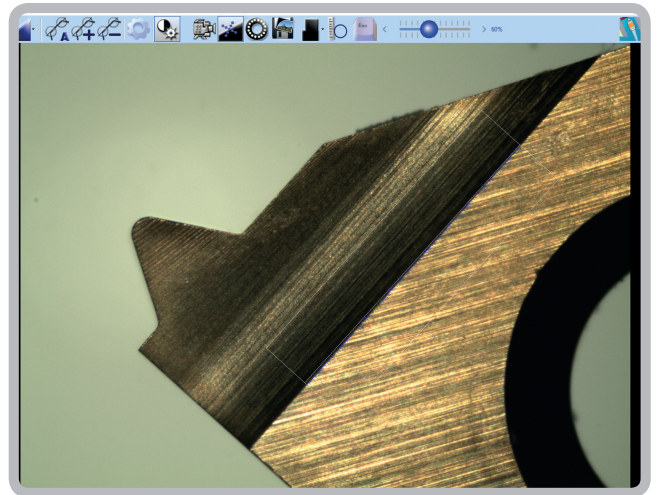
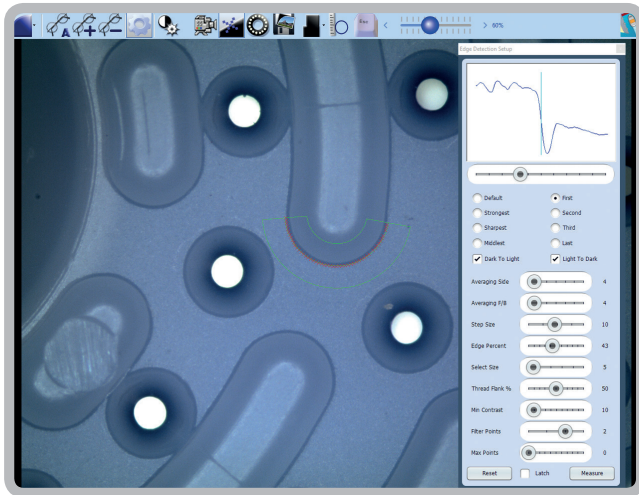

### CAD Option

Allows measurement data points taken anywhere on the part surface to be compared to a 3D IGES or STEP CAD model.

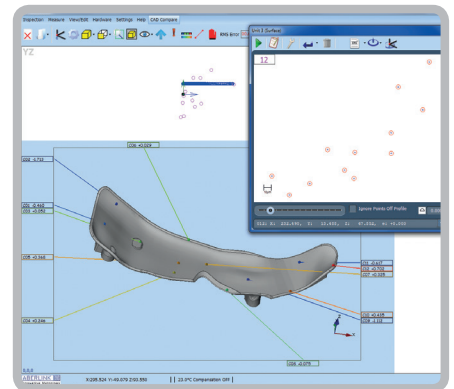
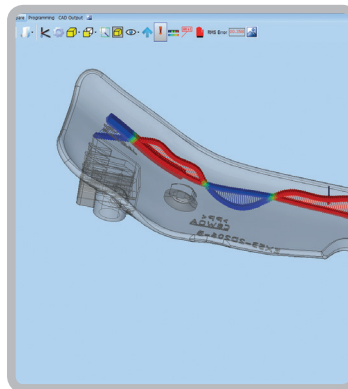

## Flexmaster Fixtures

Flexmaster components introduce new technology. Our self-wedging clamps offer near zero clamping force. Sliding t-nut tooling blocks provide an infinite variety of fixture solutions.

Even the corner joiners for our frame are dual purpose, providing ridges that allow backlighting to illuminate edges for inspection.

### Fixture frame assembly, includes the following:

- 4 off linear slide-frames with t-slots, and laser marked reference scales
- 4 off ridged two-way T-nuts for corner joining and part location
- 4 off sliding hold-down brackets with slots for 2 axis adjustment to mount t-slot frames to venture stage frame

### Fasteners

- 30 off stainless grub screws
- 3 off long T-nuts
- 6 off short T-nuts
- 2 off T-nuts with machined vee in end
- 12 off locknut with threaded ID.  
(For use with clamp rods, thumbscrew, and spherical locator pin)

### Clamps and Rods

- 2 off narrow 'soft-touch' self-wedging tail-spring clamp
- 2 off wide 'soft-touch' self-wedging tail-spring clamp
- 2 off self-wedging V-clamp
- 2 off ridged corner locator clamp
- 3 off stainless clamp rod.  
(Use with locknut to attach rods to slideframe, for self-wedging clamps)
- 3 off stainless clamp rod
- 2 off stainless clamp rod

### Locators

- 3 off sliding tool blocks with threaded holes for vertical clamp and adjustment
- 4 off adjustable rest button, stainless, spherical top
- 2 off additional ridged two-way t-nuts for part location
- 1 off case

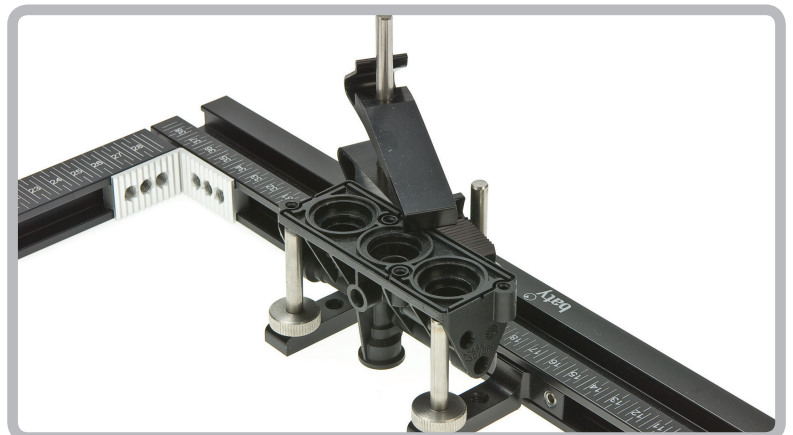
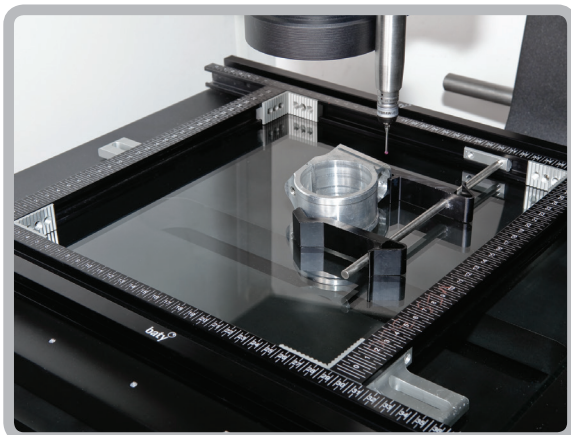
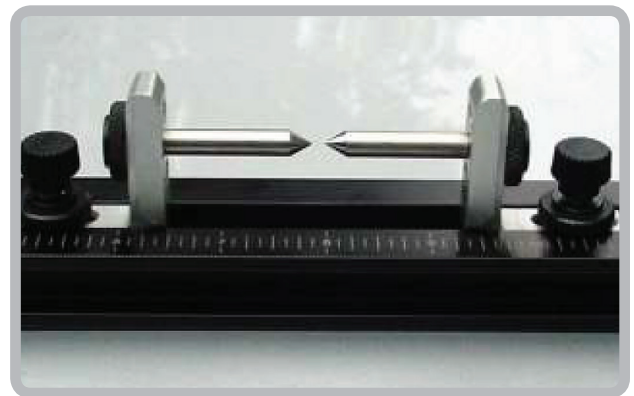
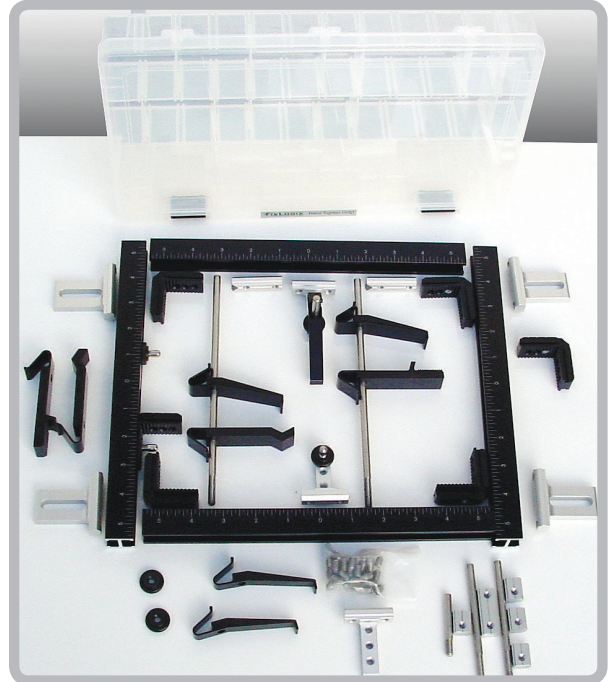

# TECHNICAL SPECIFICATION

## Manual Systems

### Manual Systems Technical Specifications

	<b>54-403-001-0</b> <b>VuMaster</b>	<b>54-251-150-0</b> <b>Venture</b>	<b>54-303-250-0</b> <b>Venture XT</b>
X Y Z measuring range (mm)	400 x 300	250 x 125 x 165	300 x 300 x 200
Workstage area (mm)	420 x 320	414 x 262	464 x 462
Max workpiece load (lb/kg)	55/25	55/25	55/25
Drive type	Manual	Manual	Manual
Bearings	Air bearings	Cross roller rail guide	Cross roller rail guide
Camera type	2048 x 1590 pixel colour USB2 camera with 8 x 9mm chip and dynamic latch		
Optics / lighting	Fixed objective telecentric lens with programmable LED lighting	6.5:1 detent zoom lens. Fully programmable software controlled white LED segmented surface lighting head with understage and through the lens (TTL) lighting as standard	
Resolution	0.001mm	0.0005mm	0.0005mm
Accuracy	7.5µm	2+L / 100	2+L / 100
Max field of view (FOV)	12mm	16mm*	16mm*
Magnification	20x 350x	Optical zoom ratio 27x - 175x on 17" monitor with digital zoom enhancement to over 1200x	
Touch probe option available	No	Yes	Yes
Probe type	N/A	Renishaw TP20	Renishaw TP20
Change rack compatible?	N/A	N/A	N/A

\*using optional 0.5x adapter lens

# TECHNICAL SPECIFICATION

## CNC Systems

### CNC Systems Technical Specifications

	54-403-005-0 VuMaster	54-251-200-0 Venture	54-303-300-0 Venture XT	54-303-646-0 Venture Plus	54-303-649-0 Venture Plus
X Y Z measuring range (mm)	400 x 300	250 x 125 x 155	300 x 300 x 200	640 x 600 x 250	640 x 900 x 250
Workstage area (mm)	420 x 320	414 x 262	464 x 462	700 x 940	700 x 1240
Max workpiece load (lb/kg)	55/25	55/25	55/25	165/75	165/75
Drive type	CNC / handwheel	CNC / joystick	CNC / joystick	CNC / joystick	CNC / joystick
Bearings	Air bearings	Cross roller rail guide	Cross roller rail guide	Air bearings	Air bearings
Max drive speed	100mm / sec	200mm / sec	200mm / sec	350mm / sec	350mm / sec
Camera type		2048 x 1590 pixel colour USB2 camera with 8 x 9mm chip and dynamic latch			
Optics / lighting	Fixed objective telecentric lens with programmable LED lighting	6.5:1 CNC zoom lens. Fully programmable software controlled white LED segmented surface lighting head with understage and through the lens (TTL) lighting as standard			
Optional		12:1 CNC zoom lens option for increased FOV	12:1 CNC zoom lens option for increased FOV	12:1 CNC zoom lens option for increased FOV	12:1 CNC zoom lens option for increased FOV
Resolution	0.001mm	0.0005mm	0.0005mm	0.0005mm	0.0005mm
Accuracy	7.5µm	2+L / 100	2+L / 100	2.4 + 0.4 / 100 Volumetric	2.4 + 0.4 / 100 Volumetric
Max field of view (FOV)	12mm	16mm*	16mm*	16mm*	16mm*
Magnification		20x 350x			
Touch probe option available	No	Yes	Yes	Yes	Yes
Probe type	N/A	Renishaw TP20	Renishaw TP20	Renishaw TP20	Renishaw TP20
Optional	N/A	Renishaw SP25 scanning probe	Renishaw SP25 scanning probe	Renishaw SP25 scanning probe	Renishaw SP25 scanning probe
Change rack compatible?	N/A	Yes	Yes	Yes	Yes

\*using optional 0.5x adapter lens

# NOTES





HIGH PRECISION

66 Rowe Street • Newton • Massachusetts 02466  
(800) 788-2353 • (617) 332-4137 fax  
www.fowlerprecision.com • sales@fowlerprecision.com

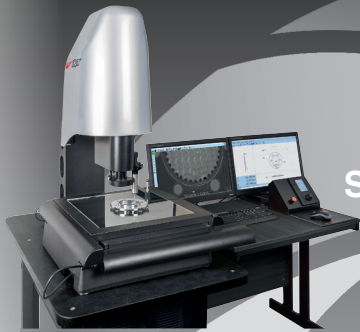

VISION SYSTEMS

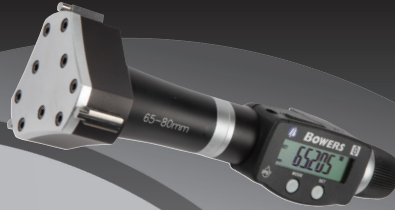

BORE GAGING

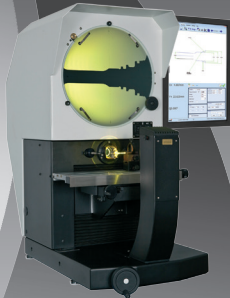

OPTICAL COMPARATORS

HEIGHT GAGES



HARDNESS TESTER



SCANNING SYSTEMS

