

DORSEY OPTICAL COMPARATORS

In the optical field, Dorsey is one of the few remaining domestically manufactured optical comparator product lines. Dorsey optical comparators demonstrate that attention to detail does matter and all are built on a foundation of stability and accuracy. Dorsey has tightened manufacturing tolerances to maintain uncompensated absolute inherent accuracy.

Below we've summarized some of the main items that should be taken into consideration when buying an optical comparator.

Step 1 – Which light path is best for your application, Vertical or Horizontal?

- **Horizontal** light path instruments have a beam of light traveling horizontally across a stage. This type of machine is ideal for large heavy parts and shafts to be held on V blocks or between centers. Typical applications include castings, transmission shafts, thread form measurement, and machined components.
- **Vertical** light path instruments have a beam of light traveling vertically. Parts being measured/inspected are placed on a plate of glass, which is on the system's XY stage, which the light beam travels through. Vertical comparators are ideal for flat parts like gaskets, O-rings, stamped parts, and electronics. Dorsey's line of vertical comparators feature quick release mechanisms on both axes, making measurements on our vertical machines much faster than on horizontal machines which feature quick release on only 1 axis.

Step 2 – What screen size and stage size best suits your application?

Screen sizes from 14" to 32" are available. Before choosing a screen size, determine how much of the part REALLY must be viewed at one time. When using a system it is not necessary to view the entire part to measure it. Calculations can be made by dividing the screen diameter by the lens magnification. For example, using a 10X lens on a 16" optical comparator would enable viewing 1.6" of the part on the screen ($16"/10=1.6"$). Keep in mind it is good practice to keep within one inch of the screen margin when viewing an image with an overlay. Verify that the stage size, travel, and weight capacity will accommodate all of the parts that are intended to be measured or inspected. In general, screen sizes 16" and smaller are benchtop units with weight capacities up to 150 pounds.

Step 3 – What lens/lenses you will require?

Follow the chart below to decide what lens will match the tolerances required. A basic rule of thumb is that a typical attentive operator can repeatedly discriminate .004" on the comparator screen. Dividing the "discernible resolution" by the lens magnification determines the minimum resolution attainable for each lens.

LENS MAGNIFICATION	DISCERNABLE RESOLUTION
5X	.0008" (0.020mm)
10X	.0004" (0.010mm)
20X	.0002" (0.005mm)
25X	.00016" (0.004mm)

LENS MAGNIFICATION	DISCERNABLE RESOLUTION
31.25X	.0001" (0.003mm)
50X	.00008" (0.002mm)
62.5X	.00006" (0.0016mm)
100X	.00004" (0.001mm)

Step 4 – What type of readout/software will you require, or will you be using overlays?

If you will be using overlays only, our base models without scales are an ideal cost effective solution. It is good practice to keep within one inch of the screen margin when viewing an image with an overlay. If measurements are required, select a basic XY digital readout if only positions and distances results are necessary. However, if measurement of circles, angles, and parametric distance is required, then select a readout or M2 software with geometric capability. Repetitive part measurement may encourage the selection of a CNC capable readout. Automatic edge sensing should be considered to eliminate operator subjectivity and increase repeatability and accuracy. See pages 91-93.

Step 5 – What options or tooling will be required?

Repeatability and accuracy will suffer if the workpiece is not properly and securely held. Careful consideration should be given to tooling and to the surface on which you place your comparator. Review pages 94 and 95 for solutions.

For assistance in selecting and configuring the correct Dorsey Comparator to meet your measurement and inspection needs, please contact us at 845-454-3111.

MODEL 14HE HORIZONTAL BEAM

The 14HE benchtop comparator is Dorsey Metrology's basic and most economical comparator with the same high quality features as the other comparators in our product line, but in a smaller package at a lower price. The addition of our extra long-life LED surface illumination is another Dorsey innovation.

FEATURES:

- ✓ 14" (350mm) angled high-resolution glass screen for optimum viewing with 90-degree cross lines, calibration reticle, and chart clips
- ✓ Reversed and inverted profile image
- ✓ Machined chart ring with vernier protractor, 1 minute graduation facilitates optimal alignment
- ✓ Coated telecentric parfocal optics
- ✓ Quick change single lens mount
- ✓ Integrated hood
- ✓ Solid cast iron, nickel plated stage
- ✓ X&Y solid rail crossed roller bearings
- ✓ Single universal dovetail stage
 - > 16" x 4" (400 x 100mm) overall stage size
 - > 8" / (200mm) X-axis travel with quick release
 - > 4" / (100mm) Y-axis travel (vertical movement/rise & fall)
 - > 50 lbs capacity
 - > ± 5 degree light source helix adjustment
- ✓ NIST traceable calibration certificate
- ✓ 1/4 micron scales are standard equipment
- ✓ 2 year limited warranty

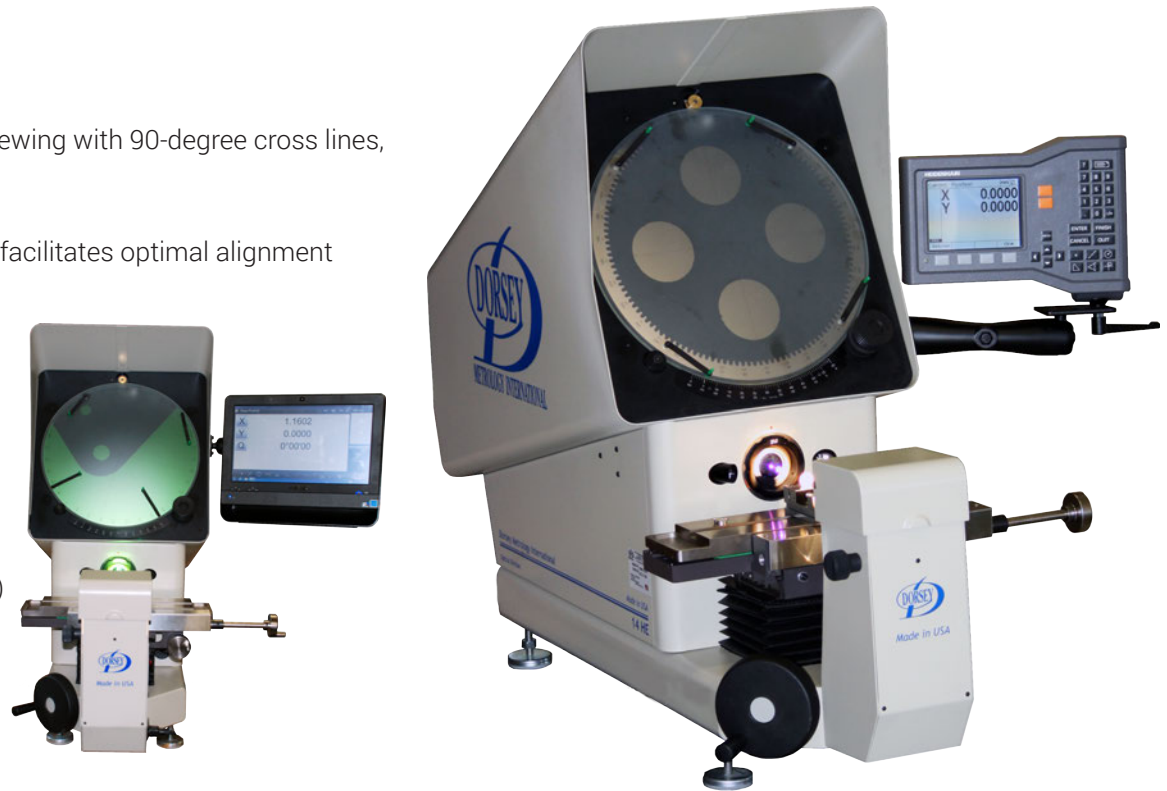

OPTIONAL FEATURES:

- ✓ Internal edge detection
- ✓ LED surface illumination
- ✓ Choice of readout options, see page 90
- ✓ Output for electronic rotary screen protractor (Q-axis) on readout with selectable 1 minute or 1/100 of a degree resolution
- ✓ Harsh Environment Package
- ✓ Additional lens magnifications available
- ✓ Tooling

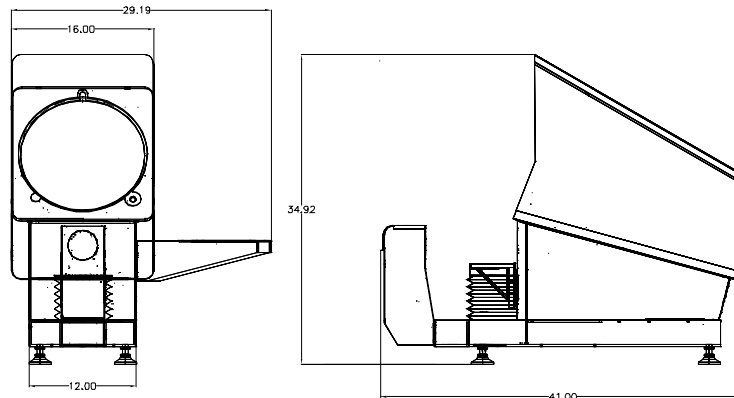

DIMENSIONS

Technical Specification	
Illumination	Profile: Built-in 24V/150W direct collimated halogen Surface: 2-Triple LED lights (optional)
Screen Size	14" (350mm) Ground glass with cross-lines
Stage	Cast iron, nickel plated, 16" x 4" single dovetail
Stage Travel	X = 8" (200mm) Y = 4" (100mm) Focus = 1.5" (38mm)
Stage Accuracy	Within +/- 0.004mm +[(L/20).001]
Linear Scale Resolution	Standard: 0.00025mm/.000010"
Repeatability of Scales	+/- 1 Scale count (0.00025mm/.000010")
Coated Telecentric Lenses	10x, 20x, 50x, 100x
Optical Accuracy	Within +/- .10% Profile, +/- .15% Surface
Power Requirements	120V or 240V AC, 50/60 Hz, 10 Amp
Weight	230 lbs/105 kg

The Benchmark 14H is an Erect Image bench top comparator and is another example of our expanding range of products. This new comparator has the same high quality features as the current product line, with an erect projection image and our "ultra-precision" crossed roller bearing stage system, but in a smaller package. The measurement scales have zero backlash and are mounted in the center of the stage travel which provides maximum measurement accuracy. The optional extra long-life LED surface illumination is another Dorsey innovation.

FEATURES:

- ✓ Erect and reversed profile image
- ✓ 14" (350mm) vertical screen for optimum viewing, high resolution ground glass screen with 90 degree cross lines, with calibration reticle and chart clips
- ✓ Machined chart ring with vernier protractor, 1 minute graduation facilitates optimal alignment
- ✓ Coated telecentric parfocal optics
- ✓ Quick change single lens mount
- ✓ Integrated hood
- ✓ Solid cast iron, nickel plated stage
- ✓ X&Y solid rail crossed roller bearings
- ✓ Single universal dovetail stage
- ✓ 16" x 4" (400x100mm) overall stage size
- ✓ 8" / (200mm) X-axis travel with quick release
- ✓ 4" / (100mm) Y-axis travel (vertical movement/rise and fall)
- ✓ 50 lbs capacity
- ✓ ± 5 degree light source helix adjustment
- ✓ LED surface illumination
- ✓ 1/4 micron scales are standard equipment
- ✓ NIST traceable calibration certificate
- ✓ 2 year limited warranty

OPTIONAL FEATURES:

- ✓ Internal edge detection
- ✓ Choice of readout options, see page 20
- ✓ Output for electronic rotary screen protractor (Q-axis) on readout with selectable 1 minute or 1/100 of a degree resolution
- ✓ Harsh Environment Package
- ✓ Additional lens magnifications available
- ✓ Tooling



DIMENSIONS

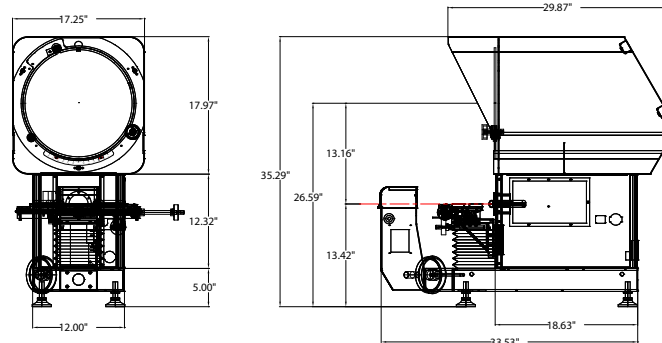

Technical Specification	
Illumination	Profile: Built-in 24V/150W direct collimated halogen Surface: 2-Triple LED lights
Screen Size	14" (350mm) Ground glass with cross-lines
Stage	Cast iron, nickel plated, 16" x 4" single dovetail
Stage Travel	X = 8" (200mm) Y = 4" (100mm) Focus = 1.5" (38mm)
Stage Accuracy	Within ± 0.0004 mm $\pm (L/20) .001$
Linear Scale Resolution	Standard: 0.00025mm/.000010"
Repeatability of Scales	± 1 Scale count (0.00025mm/.000010")
Coated Telecentric Lenses	10x, 20x, 50x, 100x
Optical Accuracy	Within $\pm .10\%$ Profile, $\pm .15\%$ Surface
Power Requirements	120V or 240V AC, 50/60 Hz, 10 Amp
Weight	250 lbs/113 kg

CONSTRUCTION FEATURES OF OUR MODEL 16H

Focus travel is always "optically coaxial"

Unique design features an intermediate plate that allows the focus axis to travel independently of the X axis

X-axis scale has zero backlash and is mounted directly under focal plane to greatly increase accuracy

Single hand quick release on X-axis

Both profile and surface illumination bulbs are located in lamphouse

True parfocal helix adjustment ± 15 degree with 5-minute vernier

Case fabrication is powder coated, not painted

Y-axis drive is located directly under the center of gravity and uses a composite steel/Delrin bevel gear set for accurate and silent operation

Ultra Precision Cast Iron Stage

Large capacity 10" x 6" travel - 150 lbs stage system

Optional 24" X axis travel

Solid cast iron - no aluminum

Lens is mounted to cast iron, nickel plated stage system - not to sheet metal case

Y-axis scale has zero backlash and is mounted on lens center line to greatly increase accuracy, all scales are dust and oil resistant

Stage is mounted to independent cast granite composite base, not sheet metal case

Solid rail crossed roller bearings in all axes

For improved stability, the weight bearing stage base rests on a rigid cast iron support system

Available with internal edge detection ("IED")

This feature provides automatic edge detection without the viewing obstruction of a plexiglass arm on the screen. The IED target is aligned directly behind the screen center crossline.

- ✔ IED is more accurate because the image is "read directly" and is not diffused through the ground glass screen.
- ✔ IED is also not subject to the stability and rigidity of a plastic arm, our IED sensor cannot be bumped out of alignment under normal use, like the external arm can.

Standard with Machined Chart Ring

Screen is mounted in precision machined chart ring for increased rigidity, optical accuracy, and improved protractor operation

Built in calibration reticle for easy magnification verification by the operator

Machined chart ring with recessed screen protects against damage, eliminates contamination of internal optics, and facilitates the alignment of the screen to the optical axis

High resolution lapped glass screen

Large format vernier protractor with one minute graduations

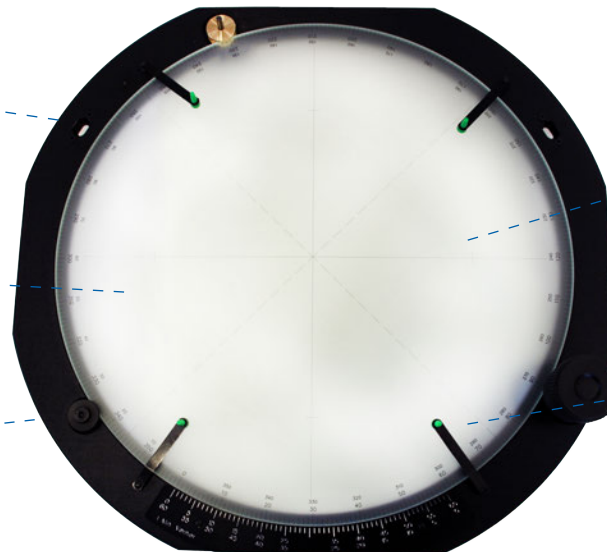

This extremely versatile measurement instrument features a robust cast granite composite base and our proven cast iron "ultra precision" stage system. This comparator comes standard with integrated fiber optic surface illumination. Measurement scales are mounted in the center of travel with zero backlash. A variety of readout options combine to make this one of the most accurate and versatile horizontal benchtop comparators.

FEATURES:

- ✓ 16" (400mm) Vertical screen for optimum viewing
- ✓ Erect and reversed profile image
- ✓ High resolution ground glass screen with calibration reticle, 90 degree cross lines, and chart clips
- ✓ Machined chart ring with vernier protractor, 1 minute graduation
- ✓ Coated telecentric parfocal optics
- ✓ Quick change single lens mount
- ✓ Fiber optic surface illumination
- ✓ Integrated hood
- ✓ Solid cast iron, nickel plated stage
 - 3-axis solid rail crossed roller bearings
 - Twin universal dovetails
 - 18" x 5" (457mmx127mm) overall size
 - 10" (250mm) X-axis travel with quick release
 - 6" (150mm) Y-axis travel (vertical movement/rise & fall)
 - 150 lbs capacity
 - ±15 degree true parfocal helix stage adjustment with 5 minute vernier
- ✓ NIST traceable calibration certificate
- ✓ 1/4 micron scales are standard equipment
- ✓ 2 Year limited warranty

OPTIONAL FEATURES:

- ✓ Internal edge detection
- ✓ Swing away lamp house arm
- ✓ 24" (610mm) extended stage travel on X-axis (50 lbs capacity), 5" (127mm) Y-axis travel (vertical movement Rise & Fall)
- ✓ Choice of readout options, see page 90
- ✓ Motorized and CNC computer controlled systems, 50 lbs capacity
- ✓ Output for electronic rotary screen protractor (Q-axis) with selectable 1 minute or 1/100 of a degree resolution
- ✓ Through-lens surface illumination
- ✓ Harsh Environment Package
- ✓ Additional lens magnifications available
- ✓ Tooling



DIMENSIONS

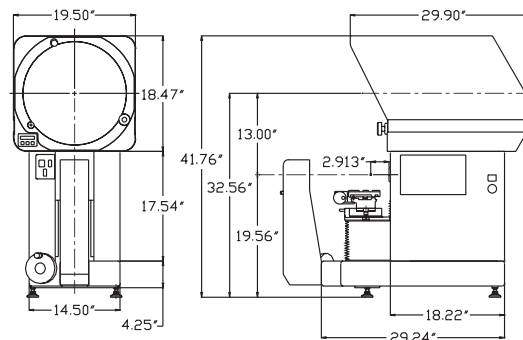

Technical Specification	
Illumination	Profile: Built-in 24V/150W direct collimated halogen Surface: Built-in 24V/250W via fiber optics
Screen Size	16" (400mm) Ground glass with cross-lines
Stage	Cast iron, nickel plated, 18" x 5", twin dovetail
Stage Travel	X = 10" (250mm) Y = 6" (150mm) Focus = 2" (50mm)
Stage Options	Optional increase of stage travel 24" (600mm) on X axis
Stage Accuracy	Within +/- 0.004mm +{(L/20).001}
Linear Scale Resolution	Standard: 0.00025mm/.000010"
Repeatability of Scales	+/- 1 Scale count (0.00025mm/.000010")
Coated Telecentric Lenses	5x, 10x, 20x, 25x, 31.25x, 50x, 62.5x, 100x
Optical Accuracy	Within +/- .10% Profile, +/- .15% Surface
Power Requirements	120V or 240V AC, 50/60 Hz, 10 Amp
Weight	460 lbs/209 kg

14H

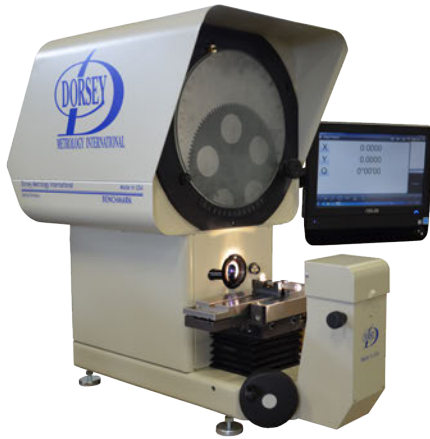

16H CNC



16H



In the optical field, Dorsey is one of the few remaining domestically manufactured optical comparator product lines. Dorsey happily acknowledges that we have learned from our customers that quality and attention to detail does matter. Dorsey optical comparators are manufactured on a foundation of rigidity and accuracy. We manufacture both horizontal and vertical comparators from 14" up to 32" screen sizes with choices of table travel and weight capacity. Standard features include cast iron, nickel coated stages, linear cross roller bearings in all axes, helix adjustment. Options include internal edge detection, and a variety of readouts from simple X-Y to motorized and complete CNC format. Dorsey has been building optical comparators for over 20 years and has thousands of satisfied customers.

16VS



24P



32P



The 24P is designed to be an all purpose measurement/inspection instrument capable of performing both light and heavy duty tasks. Choose any lens system to customize this machine to match your requirements.

FEATURES:

- ✓ 24" (600mm) Vertical screen for optimum viewing
- ✓ Erect and reversed profile image
- ✓ High resolution ground glass screen with calibration reticle, 90 degree cross lines
- ✓ Machined chart ring with vernier protractor, 1 minute graduation, and chart clips
- ✓ Coated telecentric parfocal optics
- ✓ 3 position rotary lens & condenser turret (4 position optional)
- ✓ Quartz halogen profile light source 24V, 150W
- ✓ Bright 250W fiber optic surface illumination
- ✓ Solid cast iron, nickel plated stage
 - › Triple universal dovetails accommodate wide range of fixtures
 - › 36" x 8" (914x200mm) overall size
 - › Crossed roller bearings for superior performance
 - › 500 lbs capacity
 - › 24"(610mm) X-axis motorized travel
 - › 10" (250mm) Y-axis motorized travel
 - › 3" Motorized focus travel
 - › Linear scale resolution 0.00025mm/.00001"
 - › ±15 degree true parfocal helix stage adjustment, with 5 minute vernier
 - › Joystick control, computerized microstep motor controller with X and Y axes & focus
- ✓ Integrated hood
- ✓ NIST traceable calibration certificate
- ✓ 2 Year limited warranty

OPTIONAL FEATURES:

- ✓ Internal edge detection
- ✓ Nikon optics
- ✓ Output for electronic rotary screen protractor (Q-axis) with selectable 1 minute or 1/100 of a degree resolution
- ✓ Choice of readout options, see page 90
- ✓ CNC computer controlled readout systems
- ✓ Extra bright through lens surface illumination with Nikon lens option
- ✓ Harsh Environment Package
- ✓ Wide selection of lenses
- ✓ Extended hood & curtains
- ✓ Tooling

DIMENSIONS

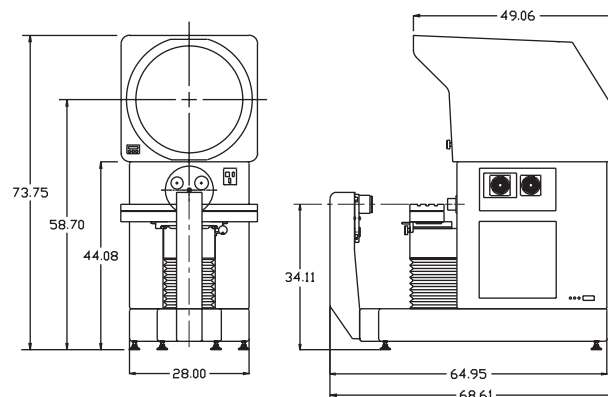

Technical Specification	
Illumination	Profile: Built-in 24V/150W direct collimated halogen Surface: Built-in 24V/250W via fiber optics
Screen Size	24" (600mm) Ground glass with cross-lines
Stage	Cast iron, nickel plated, 36" x 8", triple dovetails
Stage Travel	X = 24" (610mm), Motorized Y = 10" (250mm), Motorized Focus = 3" (75mm), Motorized
Stage Accuracy	Within +/- 0.004mm +{(L/20).001}
Linear Scale Resolution	Standard: 0.00025mm/.00001"
Repeatability of Scales	+/- 1 Scale count (0.0005mm/.00002")
Coated Telecentric Lenses	10x, 20x, 31.25x, 25x, 50x, 62.5x, 100x
Optical Accuracy	Within +/- .10% Profile, +/- .15% Surface
Power Requirements	120V or 240V AC, 50/60 Hz, 10 Amp
Weight	1980 lbs/898 kg

MODEL 32P HORIZONTAL BEAM

The 32P was designed with crisp, clear telecentric optics and a precision solid cast iron stage to be an instrument capable of handling almost any measurement/inspection requirement. This welded steel fabrication assures years of accurate, trouble free service.

FEATURES:

- ✓ 32" (800mm) Vertical screen for optimum viewing
- ✓ Erect and reversed profile image
- ✓ High resolution ground glass screen with calibration reticle, 90 degree cross lines
- ✓ Machined chart ring with vernier protractor, chart clips, 1 minute graduation facilitates optimal alignment
- ✓ Coated telecentric parfocal optics
- ✓ 3 position rotary lens & condenser turret
- ✓ Quartz halogen profile light source 24V, 150W
- ✓ Bright 500W fiber optic surface illumination
- ✓ Linear Scale Resolution 0.00025mm/.00001"
- ✓ Solid cast iron, nickel plated stage
 - Triple universal dovetails accommodate a wide range of fixtures
 - 36" x 8" (914x200mm) Overall size
 - Solid crossed roller stage bearings
 - 500 lbs capacity
 - 24" (610 mm) X-axis motorized travel
 - 10" (250mm) Y-axis motorized travel
 - 3" Motorized focus axis
 - ±15 Degree true parfocal helix stage adjustment with 5 minute vernier
 - Joystick control, computerized microstep motor controller with X and Y axes & focus
- ✓ Integrated hood
- ✓ NIST traceable calibration certificate
- ✓ 2 Year limited warranty

OPTIONAL FEATURES:

- ✓ Internal edge detection
- ✓ Output for electronic rotary screen protractor (Q-axis) with selectable 1 minute or 1/100 of a degree resolution
- ✓ Choice of readout options, see page 90
- ✓ CNC computer controlled readout systems
- ✓ Harsh Environment Package
- ✓ Extended hood & curtains
- ✓ Wide selection of lenses
- ✓ Tooling



DIMENSIONS

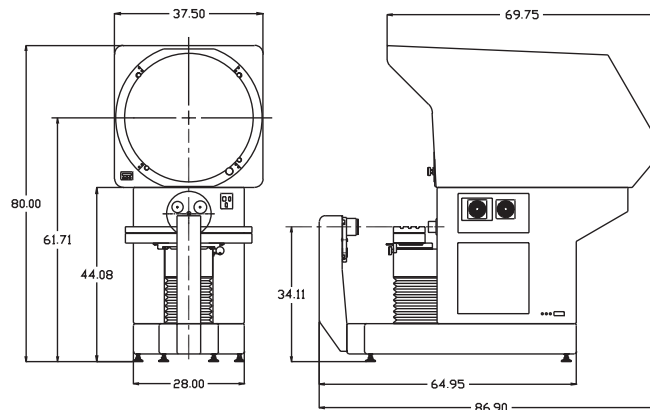

Technical Specification	
Illumination	Profile: Built-in 24V/150W direct collimated halogen Surface: Two built-in 24V/250W via fiber optics
Screen Size	32" (800mm) Ground glass with cross-lines
Stage	Cast iron, nickel plated, 36" x 8", triple dovetail
Stage Travel	X = 24" (610mm), Motorized Y = 10" (250mm), Motorized Focus = 3" (75mm), Motorized
Stage Accuracy	Within +/- 0.004mm +[(L/20).001]
Linear Scale Resolution	Standard: 0.00025mm/.000010"
Repeatability of Scales	+/- 1 Scale count (0.00025mm/.000010")
Coated Telecentric Lenses	10x, 20x, 25x, 31.25x, 50x, 62.5x, 100x
Optical Accuracy	Within +/- .10% Profile, +/- .15% Surface
Power Requirements	120V or 240V AC, 50/60 Hz, 10 Amp
Weight	3950 lbs/1792 kg

This dynamic vertical optical system is the first of its kind manufactured in the USA. This system allows a much greater stage capacity up to 50 pounds (15 lbs in the center of the glass plate) with optional stage travel up to 16" x 8".

FEATURES:

- ✓ 16" (400mm) Diameter vertical screen for optimum viewing
- ✓ Reversed and inverted image
- ✓ High resolution ground glass screen with calibration reticle, 90 degree cross lines, and chart clips
- ✓ Machined chart ring with vernier protractor
- ✓ High specification stage
 - 50 lbs stage capacity (15 lbs on glass)
 - 15" x 10.5" (350x267mm) overall size of stage
 - 11" x 7" (280x178mm) glass insert
 - 8" x 4" (200x100mm) travel
 - 4" (100mm) focal distance in the Z-axis
 - Multiple stage options with up to 16" x 8" of travel
- ✓ Quartz halogen light source. Fan cooled and electronically dimmed for long lamp life
- ✓ Dynamic optical head to maintain constant mass accuracy
- ✓ Built in rotary 3 lens turret & 2 position condenser turret
- ✓ Non coaxial surface illumination is standard
- ✓ Welded plate steel case fabrication
- ✓ Coated telecentric parfocal optics
- ✓ Lens choices of 10X through 100X
- ✓ Linear Scale Resolution .0001mm/.000004" X & Y-axis
- ✓ Choice of readout or full CNC computerized systems available
- ✓ NIST traceable calibration certificate
- ✓ 2 Year limited warranty

OPTIONAL FEATURES:

- ✓ Motorized stage
- ✓ Internal edge detection
- ✓ Coaxial surface illumination
- ✓ Output for electronic rotary screen protractor (Q-axis) with selectable 1 minute or 1/100 of a degree resolution
- ✓ Choice of readout options
- ✓ For choices of other vertical stages see page 96
- ✓ Wide selection of lenses
- ✓ Harsh Environment Package
- ✓ Tooling

DIMENSIONS

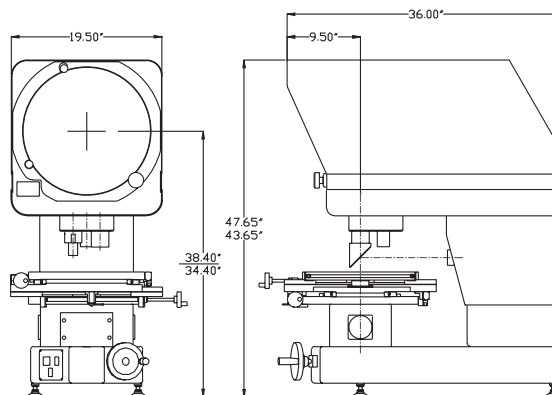

Technical Specification	
Illumination	Profile: Built-in 24V/150W direct collimated halogen Surface: 150W direct halogen
Screen Size	16" (400mm) Ground glass with cross-lines
Stage	Cast iron, nickel plated, 15" x 10.5" overall size
Stage Travel	X = 8" (200mm) Y = 4" (100mm) Focus = 4" (100mm)
Stage Accuracy	Within +/- 0.004mm +[(L/20).001]
Linear Scale Resolution	Standard: .0001/.000004" (X & Y axis)
Repeatability of Scales	+/- 1 Scale count (.0001/.000004")
Coated Telecentric Lenses	10x, 20x, 25x, 31.25x, 50x, 62.5x, 100x
Optical Accuracy	Within +/- 0.1% Profile, +/- .15% Surface
Power Requirements	120V or 240V AC, 50/60 Hz, 10 Amp
Weight	375 lbs/170 kg

ND 120 QUADRA CHEK

The ND 100 digital readouts have a monochrome flat-panel screen for displayed values, dialogs and inputs, graphics functions, and soft keys. With its sturdy housing and splash-proof membrane keyboard, the ND 120 is built for the workshop. It handles 2 or 3 axes, is capable of measuring complex geometries, graphical display of measured parts, linear, segmented and nonlinear error compensation, and features USB output.



ND 120

ND 1100/1200 QUADRA CHEK

The ND 1200 QUADRA-CHEK digital readouts have a monochrome flat-panel screen for displayed values, dialogs, and inputs. Graphics functions of the 1200 series include automatic calculation of radii, circles, angles, lines, points, and distance, and function as measuring computers for 2-D geometries.



ND 1100

Features:

- ✓ X and Y axes digital display
- ✓ Optional Q axis
- ✓ RS-232C PC communication interface
- ✓ USB port for printers or flash memory connectivity
- ✓ Incremental and absolute modes
- ✓ Inch/Metric selectable
- ✓ Min/max value storage
- ✓ LED display
- ✓ Geometric functions (1200 series only)
- ✓ Optional edge detection



ND 1200

ND 1300 QUADRA CHEK

The digital readouts of the ND 1300 series are characterized by the large color touchscreen. The innovative operator guidance provides self-explanatory information about the various functions. Geometric functions include automatic calculation of radii, circles, angles, lines, points, and distance.



ND 1300

Features:

- ✓ X and Y axes digital display
- ✓ Optional Q axis
- ✓ RS-232C PC communication interface
- ✓ USB port for printers or flash memory connectivity
- ✓ Incremental and absolute modes
- ✓ Inch/Metric selectable
- ✓ Min/max value storage
- ✓ Touchscreen display
- ✓ Geometric functions
- ✓ Optional edge detection
- ✓ CNC motion control option



HEIDENHAIN

Metlogix M2 software can be installed on an all-in-one touch screen PC with Microsoft Windows 7, 8.1, or 10.

METLOGIX M2 MEASURING SOLUTION FEATURES

- ✓ Clean, intuitive design
- ✓ Available in horizontal or vertical formats
- ✓ Support for optical edge or crosshair measuring systems
- ✓ Designed for multi-touch software control
- ✓ Advanced crosshair probe toolbox
- ✓ Graphics based "Part View" constructions
- ✓ Feature detail graphics
- ✓ Geometric tolerancing
- ✓ Part programs and playback
- ✓ Presentation quality reports via local file, Wifi, or LAN

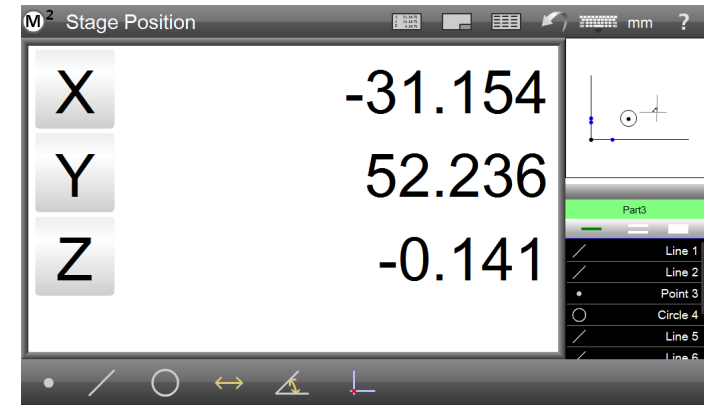

GRAPHICS-BASED "PART VIEW" CONSTRUCTIONS

Generate popular construction types, such as Distances and Tangent Lines, from within the graphical part view itself. Constructions with multiple sub-types can be toggled quickly with the "change feature type" command.

Supported construction types include:

- ✓ Average
- ✓ Mid/Center Point(s)
- ✓ End Point(s)
- ✓ Intersections
- ✓ Shortest Distance
- ✓ Farthest Distance
- ✓ Tangent Line(s)
- ✓ Gage Circle(s)
- ✓ Bolt Circle
- ✓ Angle Compliments
- ✓ Perpendicular/Parallel Line(s)
- ✓ Offset Skew Lines

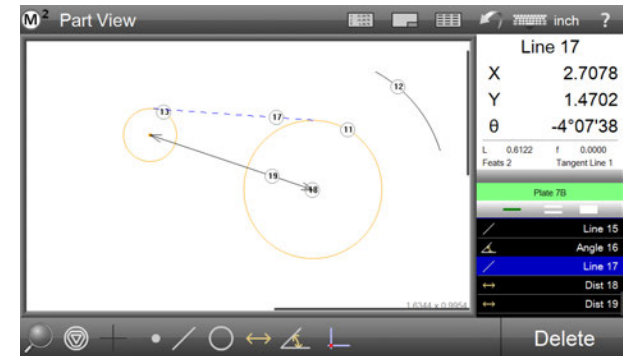

METLOGIX CNC OPTION

The **MetLogix CNC option** provides closed loop control of optical comparators. The CNC option enables automatic and repetitive part measurement, boosting productivity and helping to reduce operator subjectivity.

FEATURE DETAIL GRAPHICS

Individual feature views provide informative drawings displaying point cloud distributions as well as nominal deviations and tolerance results. Scroll through your measured features list from this view for a feature-by-feature display of Actual, Nominal, Tolerance, and Deviation results. Set the desired data fit type from the "Actual" screen using the "fit toggle" button.

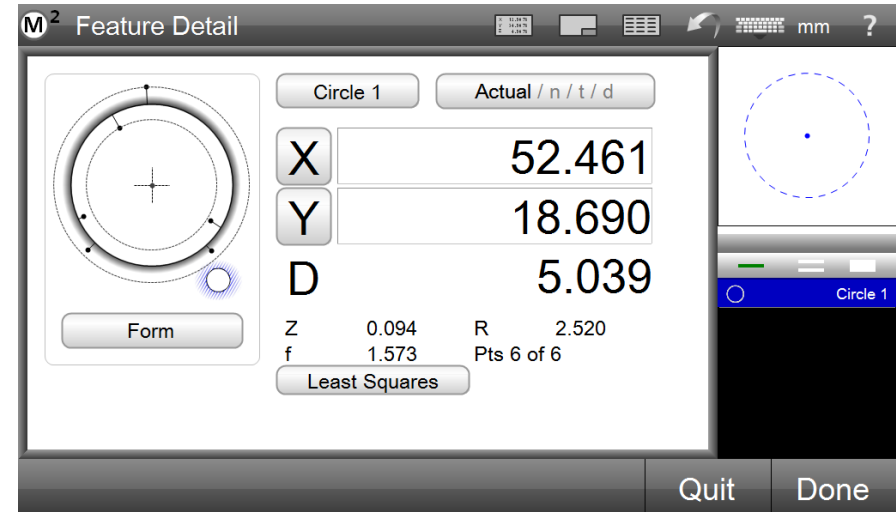

You may measure features, set nominals, apply tolerances, and view deviation results with only a few quick clicks. You may also apply a variety of popular tolerance types to features in the standard “feature-to-feature” fashion, or utilize the “place tolerancing” system for applications where tolerances are specified in a block tolerance style call out. For these cases, the M2 software lets you enter and apply universal tolerance values according to your feature resolution groupings.

SUPPORTED TOLERANCES INCLUDE:

- ✔ X/Y/Z Positional
- ✔ Diameter/Radius/Length/Width Size
- ✔ Theta (Angle)
- ✔ Form
- ✔ Parallelism
- ✔ Angularity
- ✔ True Position (LMC/MMC Modifiers)
- ✔ Straightness
- ✔ Perpendicularity
- ✔ Roundness
- ✔ Concentricity
- ✔ Runout

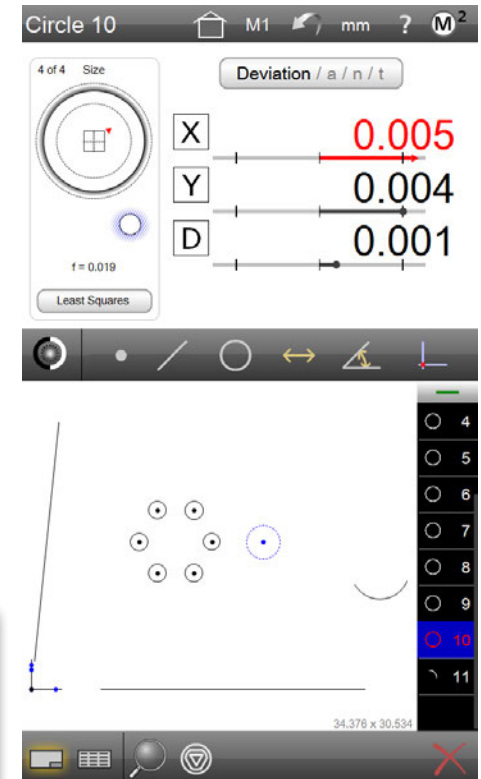

LENS TECHNICAL SPECIFICATIONS

14" SCREEN				16" SCREEN				24" SCREEN				32" SCREEN				NIKON 20 +			
LENS MAGNIFICATION	METRIC (mm)			LENS MAGNIFICATION	METRIC (mm)			LENS MAGNIFICATION	METRIC (mm)			LENS MAGNIFICATION	METRIC (mm)			LENS MAGNIFICATION	METRIC (mm)		
	A	B	C		A	B	C		A	B	C		A	B	C		A	B	C
5X	58	81	162	5X	106	138	276	5X	158	220	440	5X	196	315	630	5X	120	73	146
10X	54	81	162	10X	58	80	160	10X	79	138	276	10X	117	158	316	10X	70	79	158
20X	47	81	162	20X	40	82	164	20X	68	138	276	20X	117	109	218	20X	50	85	170
25X	40	70	140	25X	40	70	140	25X	68	118	236	25X	117	92	184	50X	50	51	101
31.25X	34	56	112	31.25X	35	56	112	50X	68	100	200	31.25X	117	79	158	100X	50	51	101
50X	28	51	102	50X	30	53	106	100X	68	48	96	50X	117	60	120				
100X	27	43	86	62.5X	30	50	100	200X	20	24	48	62.5X	117	52	104				
				100X	30	43	86					100X	117	48	96				

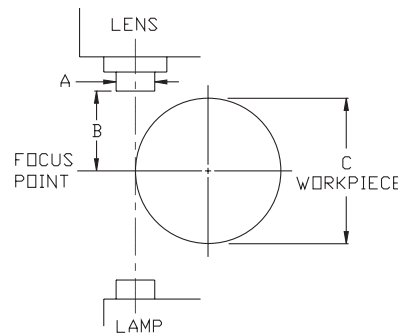
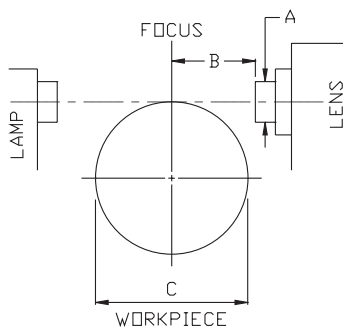



HEAVY DUTY LOCKING METAL STAND

- ✓ 28.5" x 22.3" x 27"
- ✓ Laminate top
- ✓ 2 Heavy duty locking drawers 5" & 11" deep
- ✓ Up to 1000 lbs. capacity

Part # ACC-CAB27



STAND WITH SHELF

- ✓ 24" x 36" x 32"
- ✓ Solid steel construction
- ✓ Up to 350 lbs capacity
- ✓ Durable finish

Part # ACC-CAB32



Part # ACC-16ID

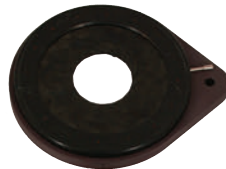

Part# ACC-24/32ID



Part # ACC-16GF



Part# ACC-24/32GF



Part# ACC-16PF

IRIS DIAPHRAGM

- ✓ Part #ACC-16ID for 16" benchtops
- ✓ Part #ACC-24/32ID for 24" & 32" floor models
- ✓ Mounts over condenser
- ✓ Used to improve collimation and reduce glare
- ✓ Improved measurement accuracy for cylindrical parts

GREEN FILTER

- ✓ Part #ACC-16GF for 16" benchtops
- ✓ Part #ACC-24/32GF for 24" & 32" floor models
- ✓ Mounts over condenser
- ✓ Monochromatic filter increases contrast and reduces optical aberrations while reducing operator eye fatigue

POLARIZING FILTER

- ✓ Part #ACC-16PF for 16" benchtops
- ✓ Part #ACC-24/32PF for 24" & 32" floor models
- ✓ Mounts over condenser
- ✓ Used to reduce glare on ground parts
- ✓ Improves contrast on translucent plastic

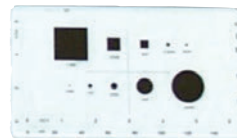

GLASS READING MASTER

- ✓ Part #ACC-MAGMM
- ✓ 3" X 16" Overall size
- ✓ 14" scale
- ✓ Fitted storage box
- ✓ NIST Traceable accuracy certification
- ✓ For magnification calibration (measuring the projected image)

CALIBRATION PROJECTION MASTER

- ✓ Part #ACC-MAGPM
- ✓ Chrome targets with 6" x 3" rule
- ✓ Inch/metric graduations
- ✓ Fitted storage box
- ✓ NIST Traceable accuracy certification
- ✓ For linear calibration and projection of magnification image



PROJECTION MASTER STAND

- ✓ Part #ACC-MAGPMF
- ✓ Designed to accurately hold and protect ACC-MAGPM during use on horizontal optical comparators
- ✓ Precision ground base
- ✓ Wooden storage box



Part # ACC-BF



Part # ACC-LBF

FIXTURE BANKING PLATES

- ✓ Part# ACC-BF 6" x 1" (150x25mm)
- ✓ Part# ACC-LBF 3" x 2.5" (75x63mm)
- ✓ Precision ground steel
- ✓ Reversible for left or right bank
- ✓ Can be used on horizontal stages



Part # ACC-V2
(Only vertical V)



Part # ACC-V1

PRECISION FIXTURE VISE

- ✓ Part# ACC-V1 jaw opening of 1.25" (32mm)
- ✓ Part# ACC-V2 jaw opening of 2.12" (54mm)
- ✓ Precision ground steel
- ✓ Vertical and horizontal V



PRECISION VISE STAND

- ✓ Fixture to hold vise in 2 axes
- ✓ Part# ACC-PVS (ACC-V1 sold separately)



Part # ACC-VB1

PRECISION V BLOCK

- ✓ Part# ACC-VB1
- ✓ Precision V block
- ✓ Hardened and ground steel
- ✓ 90 degree V 2.7" (70mm)high

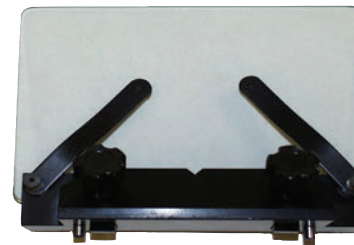

Part # ACC-VF7X5

VERTICAL GLASS FIXTURE

- ✓ Part# ACC-VF7x5
- ✓ Used to mount flat parts on horizontal comparators
- ✓ 7" x 5" (178x127mm) glass
- ✓ 2 Chart clips & V



Dorsey Products - proudly made in the USA

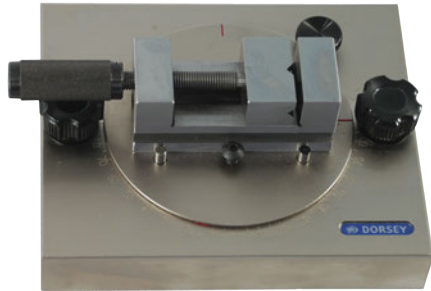

Part # ACC-RV1

ROTARY VISE STAGE

- ✓ Part# ACC-RV1 jaw opening of 1.25" (32mm)
- ✓ Part# ACC-RV2 jaw opening of 2.12" (54mm)
- ✓ Precision ground steel
- ✓ Positions vise in X, Y, or Z axis
- ✓ 360 degree rotation with 1 degree graduation



Part # ACC-RV2



Blocks lock into standard .5" dovetail

MACHINABLE FIXTURE BLOCKS

- ✓ Used to make custom fixtures
- ✓ Precision machined steel
- ✓ Available :
 - > 2" (50mm) Part #ACC-FB2
 - > 4" (100mm) Part #ACC-FB4
 - > 6" (150mm) Part #ACC-FB6
 - > 8" (200mm) Part #ACC-FB8

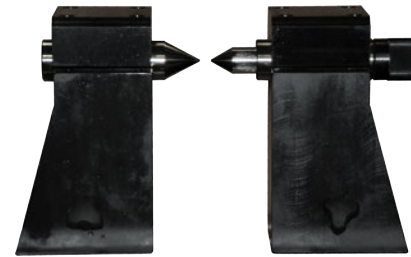

BENCH CENTERS

- ✓ Part# ACC-VBC5.38
- ✓ Matched ground hardened steel
- ✓ 90 degree V
- ✓ 5.385" (137mm) tall
- ✓ 3/4" (19mm) diameter centers with fine adjustment
- ✓ 1.25" (32mm) fixed center

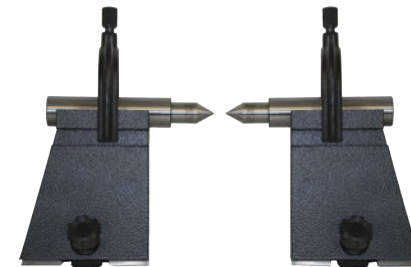

HEAVY DUTY V BLOCK & CENTER KIT

- ✓ Part# ACC-VBCHD
- ✓ Matched ground cast iron
- ✓ 90 degree V
- ✓ 5" (127mm) tall
- ✓ 1" (25mm) diameter centers with interchangeable Morse taper insert and clamps

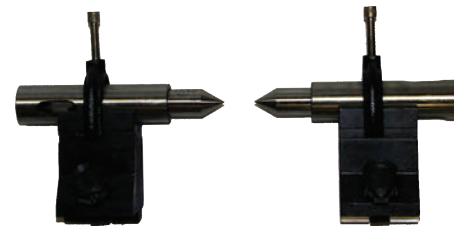

Part # ACC-VBC2.5

PRECISION V BLOCK & CENTER KIT

- ✓ Part# ACC-VBC2.5
- ✓ Matched ground hardened steel
- ✓ 90 degree V
- ✓ 2.7" (70mm) tall
- ✓ 1" (25mm) diameter centers with interchangeable Morse taper insert and clamps

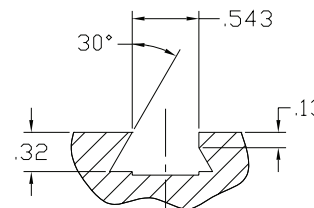

Typical universal dove tail detail used on all horizontal staging

For special fixtures contact Dorsey Metrology or your local Dorsey representative.

ULTRA PRECISION COORDINATE STAGING

These precision coordinate stages can be used for optical comparators, vision systems, or microscopes. Each stage features high precision bearings.

FEATURES:

- ✓ Solid or glass plate stages available
- ✓ High precision linear bearings
- ✓ Hard nickel plated surfaces
- ✓ Fixturing holes with universal spacing
- ✓ Quick release on both axes on all manual stages
- ✓ Static axis bias on stage drives increases accuracy
- ✓ Universal mounting options fit many existing systems
- ✓ Scale resolution of 0.1 (one tenth) micron is standard
- ✓ Motorized versions available with stepper motors
- ✓ Motorized versions available with limit switches
- ✓ Accuracy formula +/- .004 +[(L/20).001]
- ✓ NIST traceable calibration certificate
- ✓ 2 Year Warranty

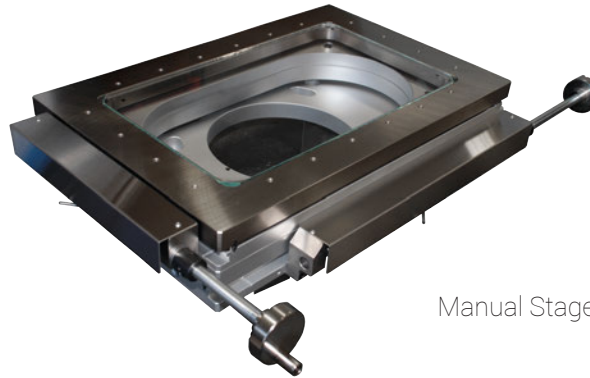

Manual Stage



Static Fixture Plate

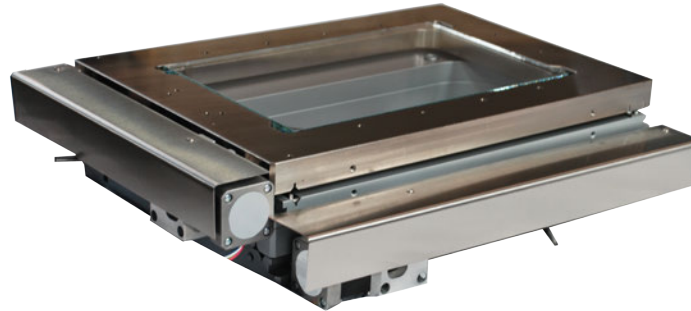

Motorized



Solid Stage

CONFIGURING A STAGE

PART NUMBER

- ✓ Select stage travel
- ✓ After stage travel, add MN for manual or MO for motorized (Special cables, controls, and joysticks priced separately).
- ✓ After MN or MO add -01 for scales
- ✓ Example: 8X4MN-01 = 8" X 4" manual stage with scales

TECHNICAL SPECIFICATIONS				STAGE TRAVEL	
STAGE TRAVEL (X/Y)	WEIGHT CAPACITY	FRAME SIZE	GLASS PLATE SIZE	MANUAL	MOTORIZED
Static fixture plate = SFP	75 lbs*	11" x 7.4"	7" x 4.5"	Static	Static
6" x 4"	75 lbs*	15" x 10.5"	11" x 7"	Available	Available
8" x 4"	75 lbs*	15" x 10.5"	11" x 7"	Available	Available
8" x 6"	75 lbs*	15" x 15"	10.5" x 10.5"	Available	Available
8" x 8"	75 lbs*	15" x 15"	10.5" x 10.5"	Available	Available
12" x 4"	75 lbs*	16.5" x 7.4"	13.5" x 4.5"	Available	Available
12" x 6"	75 lbs*	16.5" x 7.4"	13.5" x 4.5"	Available	Available
12" x 12"	75 lbs*	21" x 21"	14.9" x 14.9"	Available	Available
13" x 13"	75 lbs*	20" x 20"	Solid stage only	Available	Available
16" x 6"	75 lbs*	23" x 15"	18.5" x 10.5"	Available	Available
16" x 8"	75 lbs*	23" x 15"	18.5" x 10.5"	Available	Available

*only 15 lbs on center of glass